

Submersible Waste Water Pump

Ama-Drainer 4../5..

Installation/Operating Manual



Legal information/Copyright

Installation/Operating Manual Ama-Drainer 4../5..

Original operating manual

All rights reserved. The contents provided herein must neither be distributed, copied, reproduced, edited or processed for any other purpose, nor otherwise transmitted, published or made available to a third party without the manufacturer's express written consent.

Subject to technical modification without prior notice.

© KSB SE & Co. KGaA, Frankenthal 03/01/2020

Contents

	Glossary	5
1	General.....	6
	1.1 Principles	6
	1.2 Installation of partly completed machinery.....	6
	1.3 Target group.....	6
	1.4 Other applicable documents.....	6
	1.5 Symbols	6
	1.6 Key to safety symbols/markings.....	7
2	Safety	8
	2.1 General.....	8
	2.2 Intended use	8
	2.3 Personnel qualification and training.....	8
	2.4 Consequences and risks caused by non-compliance with this manual	9
	2.5 Safety awareness	9
	2.6 Safety information for the operator/user	9
	2.7 Safety information for maintenance, inspection and installation	9
	2.8 Unauthorised modes of operation	10
3	Transport/Temporary Storage/Disposal.....	11
	3.1 Checking the condition upon delivery	11
	3.2 Transport.....	11
	3.3 Storage/preservation	11
	3.4 Return to supplier.....	11
	3.5 Disposal	12
4	Description of the Pump (Set).....	13
	4.1 General description	13
	4.2 Product information as per Regulation No. 1907/2006 (REACH).....	13
	4.3 Designation.....	14
	4.4 Name plate.....	15
	4.5 Design details.....	15
	4.6 Configuration and function.....	17
	4.7 Scope of supply.....	18
	4.8 Noise characteristics	18
	4.9 Dimensions and weights	18
5	Installation at Site	19
	5.1 Safety regulations.....	19
	5.2 Checks to be carried out prior to installation.....	19
	5.2.1 Checking the operating data	19
	5.2.2 Preparing the place of installation	19
	5.3 Installing the pump set	20
	5.4 Piping	20
	5.4.1 Connecting the piping.....	20
	5.5 Electrical system.....	21
	5.5.1 Information for planning the control system	21
	5.5.2 Setting the overload protection device.....	22
	5.5.3 Connecting the level control equipment	22
	5.5.4 Connection to power supply	23
	5.6 Checking the direction of rotation.....	23
6	Commissioning/Start-up/Shutdown.....	25
	6.1 Commissioning/Start-up	25
	6.1.1 Prerequisites for commissioning/start-up	25
	6.1.2 Start-up/shutdown	25

6.2	Operating limits.....	26
6.2.1	Frequency of starts.....	26
6.2.2	Operation on the power supply network	26
6.2.3	Fluid handled	27
6.3	Shutdown/storage/preservation	29
6.3.1	Measures to be taken for shutdown	29
6.4	Returning to service	29
7	Servicing/Maintenance.....	30
7.1	Safety regulations.....	30
7.2	Servicing/inspection.....	30
7.3	Drainage/disposal	30
7.4	Dismantling the pump set.....	31
7.5	Reassembling the pump set.....	33
7.6	Tightening torques.....	34
7.7	Recommended spare parts stock	34
8	Trouble-shooting.....	35
9	Related Documents	37
9.1	General assembly drawing with list of components	37
9.1.1	General assembly drawing of Ama-Drainer .../10, .../10K, .../35.....	37
9.1.2	General assembly drawing Ama-Drainer 522/11.....	40
9.2	Dimensions and connections	42
9.2.1	Single pumps.....	42
9.2.2	Examples of transportable models	45
9.2.3	Examples of stationary installation.....	47
9.2.4	Installation example of a dual-pump station.....	49
9.3	Wiring diagrams	50
9.3.1	Ama-Drainer SE.....	50
9.3.2	Ama-Drainer NE	51
9.3.3	Ama-Drainer SD	52
9.3.4	Ama-Drainer ND.....	53
10	EU Declaration of Conformity	54
11	EU Declaration of Conformity	55
12	Certificate of Decontamination.....	56
	Index	57

Glossary

Backflow

Waste water flowing back from the sewer into the connected drainage piping

submerged. They may be operated outside the fluid for short periods of time, until the minimum fluid level has been reached.

Certificate of decontamination

A certificate of decontamination is enclosed by the customer when returning the product to the manufacturer to certify that the product has been properly drained to eliminate any environmental and health hazards arising from components in contact with the fluid handled.

Waste water

Water consisting of a combination of water discharged from households, industrial and other businesses as well as surface water.

Close-coupled design

Motor directly fitted to the pump via a flange or a drive lantern

Discharge line

Pipe for transporting waste water to a level above the flood level into the sewer system

DOL starting

For low power ratings (usually up to 4 kW), the three-phase motor is connected directly to the mains voltage.

EN 12050-2

European Standard for waste water lifting units which are used to dispose of faeces-free waste water occurring below the flood level of buildings and sites. It defines general requirements as well as principles of construction and testing.

Flood level

Maximum backflow level of waste water in a drainage system

Hydraulic system

The part of the pump in which the kinetic energy is converted into pressure energy

Pump

Machine without drive, additional components or accessories

Pump set

Complete pump set consisting of pump, drive, additional components and accessories

Submersible motor pump

Submersible motor pumps are floodable, close-coupled units which are not self-priming. The pumps are usually operated completely

1 General

1.1 Principles

This operating manual is valid for the type series and variants indicated on the front cover.

The operating manual describes the proper and safe use of this equipment in all phases of operation.

The name plate indicates the type series, the main operating data and the serial number. The serial number uniquely describes the product and is used as identification in all further business processes.

In the event of damage, immediately contact your nearest KSB service facility to maintain the right to claim under warranty.

1.2 Installation of partly completed machinery

To install partly completed machinery supplied by KSB refer to the sub-sections under Servicing/Maintenance.

1.3 Target group

This operating manual is aimed at the target group of trained and qualified specialist technical personnel. (⇒ Section 2.3, Page 8)

1.4 Other applicable documents

Table 1: Overview of other applicable documents

Document	Contents
Sub-supplier product literature	Operating manuals and other product literature describing accessories and integrated machinery components

For accessories and/or integrated machinery components observe the product literature of the relevant manufacturer.







1.5 Symbols

Table 2: Symbols used in this manual

Symbol	Description
✓	Conditions which need to be fulfilled before proceeding with the step-by-step instructions
▷	Safety instructions
⇒	Result of an action
⇔	Cross-references
1. 2.	Step-by-step instructions
	Note Recommendations and important information on how to handle the product

1.6 Key to safety symbols/markings

Table 3: Definition of safety symbols/markings

Symbol	Description
	DANGER This signal word indicates a high-risk hazard which, if not avoided, will result in death or serious injury.
	WARNING This signal word indicates a medium-risk hazard which, if not avoided, could result in death or serious injury.
	CAUTION This signal word indicates a hazard which, if not avoided, could result in damage to the machine and its functions.
	General hazard In conjunction with one of the signal words this symbol indicates a hazard which will or could result in death or serious injury.
	Electrical hazard In conjunction with one of the signal words this symbol indicates a hazard involving electrical voltage and identifies information about protection against electrical voltage.
	Machine damage In conjunction with the signal word CAUTION this symbol indicates a hazard for the machine and its functions.



2 Safety

All the information contained in this section refers to hazardous situations.

In addition to the present general safety information the action-related safety information given in the other sections must be observed.

2.1 General

- This operating manual contains general installation, operating and maintenance instructions that must be observed to ensure safe operation of the system and prevent personal injury and damage to property.
- Comply with all the safety instructions given in the individual sections of this operating manual.
- The operating manual must be read and understood by the responsible specialist personnel/operators prior to installation and commissioning.
- The contents of this operating manual must be available to the specialist personnel at the site at all times.
- Information and markings attached directly to the product must always be complied with and kept in a perfectly legible condition at all times. This applies to, for example:
 - Arrow indicating the direction of rotation
 - Markings for connections
 - Name plate
- The operator is responsible for ensuring compliance with all local regulations not taken into account.

2.2 Intended use

- The pump (set) must only be operated in the fields of application and within the use limits specified in the other applicable documents.
- Only operate pumps/pump sets which are in perfect technical condition.
- Do not operate the pump (set) in partially assembled condition.
- Only use the pump to handle the fluids described in the data sheet or product literature of the pump model or variant.
- Never operate the pump without the fluid to be handled.
- Observe the minimum flow rates indicated in the data sheet or product literature (to prevent overheating, bearing damage, etc).
- Observe the minimum flow rate and maximum flow rate indicated in the data sheet or product literature (to prevent overheating, mechanical seal damage, cavitation damage, bearing damage, etc.).
- Do not throttle the flow rate on the suction side of the pump (to prevent cavitation damage).
- Consult the manufacturer about any use or mode of operation not described in the data sheet or product literature.

2.3 Personnel qualification and training

All personnel involved must be fully qualified to transport, install, operate, maintain and inspect the machinery this manual refers to.

The responsibilities, competence and supervision of all personnel involved in transport, installation, operation, maintenance and inspection must be clearly defined by the operator.

Deficits in knowledge must be rectified by means of training and instruction provided by sufficiently trained specialist personnel. If required, the operator can commission the manufacturer/supplier to train the personnel.

Training on the pump (set) must always be supervised by technical specialist personnel.

2.4 Consequences and risks caused by non-compliance with this manual

- Non-compliance with these operating instructions will lead to forfeiture of warranty cover and of any and all rights to claims for damages.
- Non-compliance can, for example, have the following consequences:
 - Hazards to persons due to electrical, thermal, mechanical and chemical effects and explosions
 - Failure of important product functions
 - Failure of prescribed maintenance and servicing practices
 - Hazard to the environment due to leakage of hazardous substances

2.5 Safety awareness

In addition to the safety information contained in this operating manual and the intended use, the following safety regulations shall be complied with:

- Accident prevention, health regulations and safety regulations
- Explosion protection regulations
- Safety regulations for handling hazardous substances
- Applicable standards, directives and laws

2.6 Safety information for the operator/user

- Fit protective equipment (e.g. contact guards) supplied by the operator for hot, cold or moving parts, and check that the equipment functions properly.
- Do not remove any protective equipment (e.g. contact guards) during operation.
- Provide the personnel with protective equipment and make sure it is used.
- Contain leakages (e.g. at the shaft seal) of hazardous fluids handled (e.g. explosive, toxic, hot) so as to avoid any danger to persons and the environment. Adhere to all relevant laws.
- Eliminate all electrical hazards. (In this respect refer to the applicable national safety regulations and/or regulations issued by the local energy supply companies.)
- If shutting down the pump does not increase potential risk, fit an emergency-stop control device in the immediate vicinity of the pump (set) during pump set installation.
- Make sure the system cannot be accessed by unauthorised persons (e.g. children).

2.7 Safety information for maintenance, inspection and installation

- Modifications or alterations of the pump (set) are only permitted with the manufacturer's prior consent.
- Use only original spare parts or parts/components authorised by the manufacturer. The use of other parts/components can invalidate any liability of the manufacturer for resulting damage.
- The operator ensures that maintenance, inspection and installation are performed by authorised, qualified specialist personnel who are thoroughly familiar with the manual.
- Only carry out work on the pump (set) during standstill of the pump.
- Only perform work on the pump set when it has been disconnected from the power supply (de-energised).
- The pump (set) must have cooled down to ambient temperature.
- Pump pressure must have been released and the pump must have been drained.

- When taking the pump set out of service always adhere to the procedure described in the manual. (⇒ Section 6.3, Page 29)
- Decontaminate pumps which handle fluids posing a health hazard.
- As soon as the work has been completed, re-install and re-activate any safety-relevant devices and protective devices. Before returning the product to service, observe all instructions on commissioning. (⇒ Section 6.1, Page 25)

2.8 Unauthorised modes of operation

Never operate the pump (set) outside the limits stated in the data sheet and in this manual.

The warranty relating to the operating reliability and safety of the supplied pump (set) is only valid if the equipment is used in accordance with its intended use.

3 Transport/Temporary Storage/Disposal

3.1 Checking the condition upon delivery

1. On transfer of goods, check each packaging unit for damage.
2. In the event of in-transit damage, assess the exact damage, document it and notify KSB or the supplying dealer and the insurer about the damage in writing immediately.

3.2 Transport

	<p>! WARNING</p>
	<p>Improper lifting/moving of heavy assemblies or components Personal injury and damage to property!</p> <ul style="list-style-type: none"> ▷ Use suitable transport devices, lifting equipment and lifting tackle to move heavy assemblies or components.
	<p>CAUTION</p>
	<p>Improper transport Damage to the pump (set)!</p> <ul style="list-style-type: none"> ▷ To transport the pump / pump set always use the handle. ▷ Never suspend the pump (set) from the float switch or power cable to lift it up or transport it. ▷ Prevent the pump (set) from getting knocked or dropped.

3.3 Storage/preservation

	<p>CAUTION</p>
	<p>Damage during storage due to frost, humidity, dirt, UV radiation or vermin Corrosion/contamination of the pump!</p> <ul style="list-style-type: none"> ▷ Store the pump (set) in a dry, dark, frost-proof room not exposed to sunlight where the atmospheric humidity is as constant as possible.



Store the pump (set) vertically in a dry, dark, frost-proof room not exposed to sunlight. Under these conditions it does not need additional preservation.

3.4 Return to supplier

1. Drain the pump as per operating instructions.
2. Always flush and clean the pump, particularly if it has been used for handling noxious, hot or other hazardous fluids.
3. If the fluids handled by the pump (set) leave residues which might lead to corrosion when coming into contact with atmospheric humidity, or which might ignite when coming into contact with oxygen, the pump set must be neutralised, and anhydrous inert gas must be blown through the pump for drying purposes.
4. Always complete and enclose a certificate of decontamination when returning the pump (set). (⇒ Section 12, Page 56)
 Always indicate any safety and decontamination measures taken.

	<p>NOTE</p>
	<p>If required, a blank certificate of decontamination can be downloaded from the following web site: www.ksb.com/certificate_of_decontamination</p>

3.5 Disposal

	<p> WARNING</p>
	<p>Fluids, consumables and supplies posing a health hazard Hazard to persons and the environment!</p> <ul style="list-style-type: none"> ▷ Collect and dispose of any preservatives, flushing liquids and fluid residues. ▷ Wear safety clothing and a protective mask, if required. ▷ Observe all legal regulations on the disposal of fluids posing a health hazard.

1. Dismantle the product.
Collect greases and other lubricants during dismantling.
2. Separate and sort the materials, e.g. by:
 - Metals
 - Plastics
 - Electronic waste
 - Greases and other lubricants
3. Dispose of materials in accordance with local regulations or in another controlled manner.

Electrical or electronic equipment marked with the adjacent symbol must not be disposed of in household waste at the end of its service life.

Contact your local waste disposal partner for returns.

If the used electrical or electronic equipment contains personal data, the operator is responsible for deleting it before the equipment is returned.

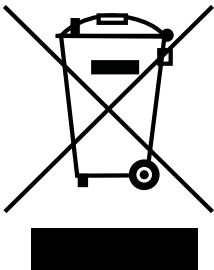

4 Description of the Pump (Set)

4.1 General description

- Submersible waste water pump (see submersible motor pump)

Variant A (standard design)

- Chemically neutral waste water
- Slightly contaminated waste water (up to 40 °C max.)
- Wash water (up to 90 °C max. for short periods $t \leq 3$ minutes)

Free passage 10/11 mm:

- Solid particles with a particle size of up to 10 or 11 mm

Free passage 35 mm:

- Waste water containing long fibres and stringy material
- Solid particles with a particle size of up to 35 mm

Variant C for aggressive fluids

In addition to standard variant:

- Swimming pool water¹⁾
- Brackish water
- Seawater
- Water containing salt
- Aggressive fluids
- Condensate from heat recovery applications

Variant R (for water containing oil / oil emulsions)

In addition to standard variant:

- Oil emulsions and cutting oils
- Waste water containing oil

4.2 Product information as per Regulation No. 1907/2006 (REACH)

For information as per chemicals Regulation (EC) No. 1907/2006 (REACH), see <http://www.ksb.com/reach>.

1) Swimming pool water (0.4 to 1.4 mg/l free chlorine, max. 0.6 mg/l combined chlorine, pH 6.9 to 7.7, water hardness 10 to 30 °dH, max. salt content 7 g/l)

4.3 Designation

Example: Ama-Drainer A 4 22 S D / 10 K

Table 4: Designation key

Code	Description	
Ama-Drainer	Type series	
A	Material variant	
	A	Standard variant
	C	Variant for aggressive water
	R	Variant for water containing oil / oil emulsions
4	Nominal discharge nozzle diameter	
	4	~ 40 mm (G 1 1/2)
	5	~ 50 mm (G 2)
22	Motor rating [kW x 10]	
	05	0.55 kW
	07	0.75 kW
	11	1.1 kW
	15	1.5 kW
	22	2.2 kW
S	Float switch	
	S	With float switch
	N	Without float switch
D	Motor	
	D	Three-phase motor
	E	Single-phase alternating current
10	Free passage [mm]	
	10	10 mm
	11	11 mm
	35	35 mm
K	Cooling jacket	
	K	With cooling jacket
	-2)	Without cooling jacket

2) Blank

4.4 Name plate

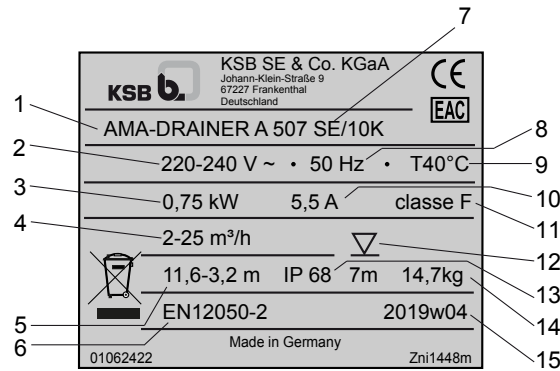

Fig. 1: Name plate (example)

1	Type series, size	9	Maximum fluid temperature
2	Rated voltage	10	Rated current
3	Rated power	11	Thermal class of winding insulation
4	Flow rate ($Q_{min.} / Q_{max.}$)	12	Maximum immersion depth
5	Head ($H_{min.} / H_{max.}$)	13	Enclosure
6	Principles of construction and testing	14	Total weight
7	Power cable version (e.g. E= single-phase)	15	Serial number (year of production, week of production)
8	Rated frequency		

4.5 Design details

Design

- Fully floodable submersible motor pump
- Close-coupled design
- Single-stage
- To EN 12050-2
- Vertical discharge nozzle
- With or without level control

Installation

- Vertical installation
- Wet-installed transportable model
- Wet-installed stationary model

Drive

- Motor winding to IEC 60038
- Motor design to EN 60043 T1/IEC 34-1
- Thermal class F
- DOL starting
- Enclosure IP68 (permanently submerged) to EN 60529 / IEC 529

Ama-Drainer NE/SE 10/35

- AC motor
- Integrated temperature switches
- 10-metre power cable
- Shockproof plug

Ama-Drainer SD 10/11/35

- Three-phase motor
- Integrated temperature switches
- 10-metre power cable
- CEE plug (3L+PE+N) with motor contactor and phase inverter

Ama-Drainer ND 10/11/35

- Three-phase motor
- Integrated temperature switches
- 10-metre power cable with free cable end and protective cap

Shaft seal

- Pump end, 1 bi-directional mechanical seal
- Drive end: 1 shaft seal ring
- Liquid reservoir between the seals for cooling and lubrication

Impeller type

- Open multi-vane impeller
- Free-flow impeller

Bearings

- Maintenance-free
- Grease-packed rolling element bearings sealed for life

4.6 Configuration and function

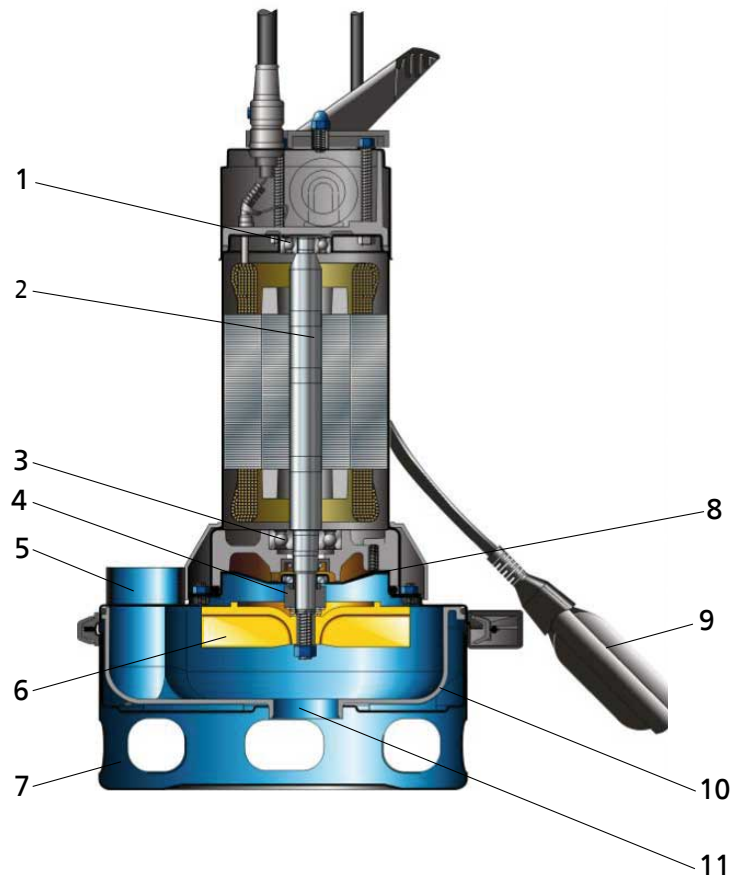

Fig. 2: Sectional drawing

1	Bearing, motor end	2	Shaft
3	Bearing, pump end	4	Shaft seal
5	Discharge nozzle	6	Impeller
7	Foot	8	Pump casing
9	Float switch	10	Volute casing
11	Suction nozzle		

Design The pump is designed with a vertical fluid inlet and a vertical outlet. The hydraulic system sits on the extended motor shaft. The shaft runs in common bearings.

Function The fluid enters the pump axially via the suction nozzle (11) and is accelerated outward by the rotating impeller (6). In the flow passage of the volute casing (10) the kinetic energy of the fluid is converted into pressure energy. The fluid is pumped to the discharge nozzle (5), where it leaves the pump. At the rear side of the impeller, the shaft (2) enters the pump casing (8) which houses the hydraulic system. The shaft passage through the pump casing is sealed to atmosphere with a shaft seal (4). The shaft runs in rolling element bearings (1) and (3).

4.7 Scope of supply

Depending on the model, the following items are included in the scope of supply:

- Pump set
- Connection socket or discharge elbow with internal thread
- 10-metre power cable

For ...SE / ...SD:

- Float switch

Accessories

- Control units for proper operation of the pump sets

4.8 Noise characteristics







Sound pressure level < 70 dB(A)

4.9 Dimensions and weights

For dimensions and weights refer to the general arrangement drawing/outline drawing or data sheet of the pump set.

5 Installation at Site

5.1 Safety regulations

	 DANGER
	<p>Unsuitable electrical installation Danger to life!</p> <ul style="list-style-type: none"> ▷ Make sure the electrical installation meets the VDE 0100 installation rules (i.e. sockets with earthing terminals). ▷ Make sure the electric mains is equipped with a residual current device of maximum 30 mA. ▷ Always have the electrical connections installed by a trained and qualified electrician.
	 DANGER
	<p>Use in an outdoor area Danger of death from electric shock!</p> <ul style="list-style-type: none"> ▷ Any extension cords must match the quality of the supplied pump cable (10-metre cable length). ▷ Do not expose electrical connections to any moisture.
	 DANGER
	<p>Continuous pump operation in swimming pools, garden ponds or similar Danger of death from electric shock!</p> <ul style="list-style-type: none"> ▷ Make sure that nobody is in the water while the pump is in operation. ▷ Only use the pump for draining swimming pools, garden ponds, etc. (It is impermissible to use this pump as a recirculation pump, for example.)

5.2 Checks to be carried out prior to installation

Before beginning with the installation check the following:

- The pump set can be operated on the power supply network according to the data on the name plate.
- The fluid to be handled matches the description of suitable fluids.
- All structural work required has been checked and prepared in accordance with the dimensions in the outline drawing.

5.2.1 Checking the operating data

Before installing the pump set, verify that the name plate data matches the data given in the purchase order and the site system data.

5.2.2 Preparing the place of installation

1. Check the structural requirements.
All structural work required must have been prepared in accordance with the dimensions stated in the outline drawing/general arrangement drawing.

5.3 Installing the pump set

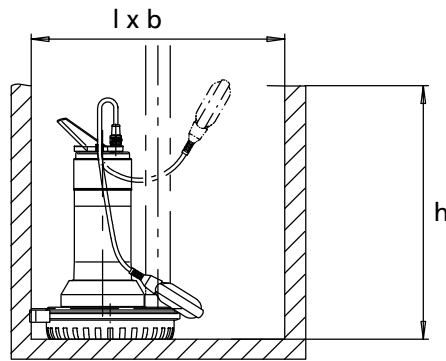

Fig. 3: Dimensions for installation

Table 5: Recommended installation dimensions

Type series	$l \times b^{3)}$	$h^{3)}$
	[mm]	[mm]
Ama-Drainer 4..SE/10	500 × 500	500
Ama-Drainer 5..SD/10 K		
Ama-Drainer 4..SD/35		550
Ama-Drainer 522/11		

1. For transporting and lifting the pump observe the following notes.
(⇒ Section 3.2, Page 11)
2. If required, suspend the pump using a rope attached to the handle.
3. Place the pump on a solid surface.
4. Make sure that the float can move freely.

5.4 Piping

5.4.1 Connecting the piping

	⚠ DANGER
	<p>Impermissible loads acting on the pump nozzles Danger to life from escaping hot, toxic, corrosive or flammable fluids!</p> <ul style="list-style-type: none"> ▷ Do not use the pump as an anchorage point for the piping. ▷ Anchor the pipes in close proximity to the pump and connect them properly without transmitting any stresses or strains. ▷ Observe the permissible forces and moments at the pump nozzles. ▷ Take appropriate measures to compensate for thermal expansion of the piping.
	NOTE
	<p>Installing check and shut-off elements in the system is recommended, depending on the type of plant and pump. However, such elements must not obstruct proper drainage or hinder disassembly of the pump.</p>

2331.826/11-EN

3) Minimum values

NOTE

The highest point of the discharge line must be above the flood level (usually street level) to prevent any backflow from the sewage system.

Transportable model

1. Connect the discharge nozzle to a hose with a suitable adapter (e.g. Storz coupling)

Stationary installation

- Ama-Drainer 405 ... 422

1. Connect the pump to the discharge line with a G 1 1/2 threaded socket. Use a pipe with an inside diameter of 40 mm.

- Ama-Drainer 505/10 K ... 522/10 K

1. Connect the pump to the discharge line with a G 2 threaded socket. Use a pipe with an inside diameter of 50 mm.

- Ama-Drainer 522/11

1. Connect the pump to the discharge line with a G 2 threaded socket. Use a pipe with an inside diameter of 50 mm. This pump is also suitable for stationary installation in a sump with a duckfoot bend and guide wire or guide rail arrangement.

5.5 Electrical system

5.5.1 Information for planning the control system

NOTE

When laying a cable between the control system and the pump set's connection point, verify that the number of cores is sufficient for the sensors. A minimum cross-section of 1.5 mm² is required.

For the electrical connection of the pump set observe the wiring diagrams. (⇒ Section 9.3, Page 50)

The pump set is supplied with power cables; it is wired for DOL starting.

The motors can be connected to low-voltage grids with nominal voltages and voltage tolerances to IEC 38 or other power supply networks / power supply facilities with maximum nominal voltage tolerances of ±10 %.



Variants SD and ND:

- To ensure complete separation from the power supply network and to prevent the pump set from running on two phases only, fit an external 3-pole mechanical interlocking device (e.g. 3-pole circuit breaker).
- To ensure the pump set is switched off in the event of excessive temperatures connect the bimetal switch integrated in the winding to the control circuit. This is mandatory if:
 - The CEE plug type Hyper has been removed.
 - The pump set has a free cable end.
 - The pump set is connected to a control unit (e.g. LevelControl)
 - For any third-party products, observe the maximum load of the bimetal switch: $V_{\text{CMAX}} = 250 \text{ V AC}$, $I_{\text{CMAX}} = 1.6 \text{ A AC}$.

5.5.2 Setting the overload protection device

1. Protect the pump set against overloading by a thermal time-lag overload protection device in accordance with IEC 60947 and local regulations.
2. Set the overload protection device to the rated current specified on the name plate. (⇒ Section 4.4, Page 15)

5.5.3 Connecting the level control equipment

	CAUTION
	<p>Fluid level below the specified minimum Damage to the pump set by cavitation!</p> <p>▷ Never allow the fluid level to drop below the specified minimum.</p>
	NOTE
	<p>The pump set is switched ON/OFF with the float switch at an UPWARD/ DOWNWARD slant of approximately 40° of the float housing (clearly audible switching noise in the float housing).</p>

Automatic operation of the pump set in a tank requires the use of level control equipment.

Observe the minimum level of fluid handled. (⇒ Section 6.2.3.2, Page 28)

The ... SE / ... SD models are equipped with a float switch. Set the switching level on site.

Conditions to be met when setting the switching levels

- Observe the minimum fluid level. (⇒ Section 6.2.3.2, Page 28)
- The pump set stops before the water level falls to the level of the pump foot's suction openings.
- The pump set starts up before the water level reaches the upper edge of the tank.
- The float switch must neither come to rest at the bottom nor hit against anything at the top.
- The switching difference equals 40 cm as a minimum.

When installing two pump sets and one control unit for dual-pump stations, arrange the two float switches in a cascade. This configuration permits three switching functions:





- Alternating start-up of the two pump sets for each switching cycle.
- Additional start-up of the stand-by pump at peak load.
- Start-up of the stand-by pump should the duty pump fail.

Setting the switching levels

1. Choose an appropriate height for attaching the float switch cable.
2. Attach the float switch cable to the discharge line, the lifting lug at the handle⁴⁾ or to another suitable point.

4) On variant R the lifting lug at the handle cannot be used as an attachment point.

5.5.4 Connection to power supply

	<p>⚠ DANGER</p> <p>Electrical connection work by unqualified personnel Danger of death from electric shock!</p> <ul style="list-style-type: none"> ▷ Always have the electrical connections installed by a trained and qualified electrician. ▷ Observe regulations IEC 60364.
	<p>⚠ DANGER</p> <p>Operating a pump set that has not been fully connected Explosion hazard! Damage to the pump set!</p> <ul style="list-style-type: none"> ▷ Never start up a pump set with power cables that have not been fully connected or non-operational monitoring devices.
	<p>⚠ WARNING</p> <p>Incorrect connection to the mains Damage to the mains network, short circuit!</p> <ul style="list-style-type: none"> ▷ Observe the technical specifications of the local energy supply companies.
	<p>CAUTION</p> <p>Flow-induced motion Damage to the power cable!</p> <ul style="list-style-type: none"> ▷ Run the power cable upwards without slack.
	<p>CAUTION</p> <p>Improper routing of power cable Damage to the power cables!</p> <ul style="list-style-type: none"> ▷ Never move the power cables at temperatures below - 25 °C. ▷ Never kink or crush the power cables. ▷ Never lift the pump set by the power cables. ▷ Adjust the length of the power cables to the site requirements.

For the electrical connection observe the circuit diagrams (⇒ Section 9.3, Page 50) in the Annex and the information for planning the control system .

The pump set is supplied complete with connection cables. Always use all cables provided and connect all marked cores of the control cable.



1. Run the power cable upwards without slack and fasten it.
2. Only remove the protective caps from the power cable immediately before connection.
3. If necessary, adjust the length of the power cable to the site requirements.
4. After shortening the cable, correctly re-affix the markings of the individual cores at the cable end.

5.6 Checking the direction of rotation

Ama-Drainer SE and NE

The direction of rotation of pumps with single-phase AC motors need not be checked.

Ama-Drainer SD and ND

	<p>WARNING</p> <p>Hands inside the pump casing Risk of injuries, damage to the pump!</p> <ul style="list-style-type: none"> ▶ Always disconnect the pump set from the power supply and secure it against unintentional start-up before inserting your hands or other objects into the pump.
	<p>CAUTION</p> <p>Pump set running dry Increased vibrations! Damage to mechanical seals and bearings!</p> <ul style="list-style-type: none"> ▶ Never operate the pump set for more than 60 seconds without the fluid handled.
	<p>CAUTION</p> <p>Wrong direction of rotation Damage to the pump!</p> <ul style="list-style-type: none"> ▶ Follow the step-by-step instructions given for checking the direction of rotation.

The power cable (CEE plug) has been connected in the factory so that the pump will have the correct direction of rotation, provided that the mains' phase sequence (building supply mains) is correct.

1. Start up the pump.

⇒ If the direction of rotation is correct, the pump should show a start reaction in the direction indicated.

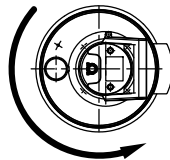

2. If the direction of rotation is incorrect, press in the phase inverter in the CEE plug with an appropriate screwdriver and turn it by 180°.

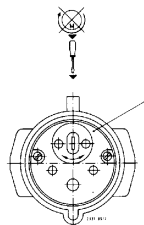

3. If the pump set is connected via a control unit, interchange wires 1 and 2 of the 6-wire cable.

6 Commissioning/Start-up/Shutdown

6.1 Commissioning/Start-up

6.1.1 Prerequisites for commissioning/start-up

Before commissioning/starting up the pump set, make sure that the following conditions are met:

- The operating data has been verified.
- The pump (set) has been installed and connected as described in this manual.
- The pump set has been properly connected to the power supply and is equipped with all protection devices.
- The direction of rotation has been checked.

6.1.2 Start-up/shutdown

Type SE/SD

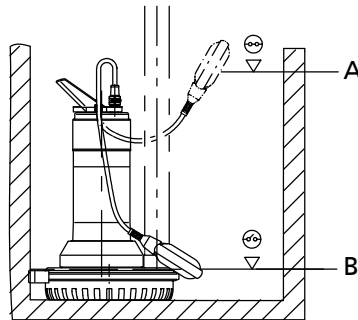

Fig. 4: Start-up/stop level

A	Start-up level	B	Stop level
---	----------------	---	------------

The pump (set) has been properly connected to the electric power supply.

The pump's automatic control system will start up the pump when the float reaches level "A" and stop it when the float reaches level "B".

Type NE/ND

The pump (set) does not need to be switched on or switched off.

It is operational as soon as it has been properly connected to the electric power supply.

- ✓ The pump (set) has been properly connected to the electric power supply.
 1. Check that the pump operates in submerged condition.

	NOTE
	A small quantity of the fluid handled will spray out into the protective casing through an internal vent bore and escape between the protective casing and the pump casing.

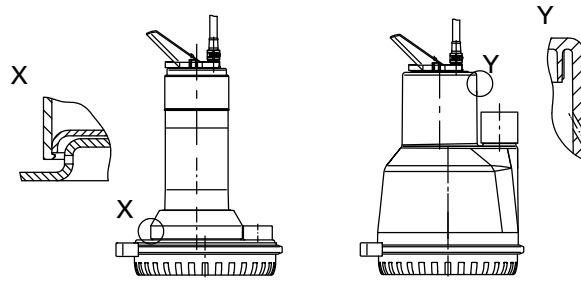

Fig. 5: Vent hole

6.2 Operating limits

6.2.1 Frequency of starts

	CAUTION
	<p>Excessive frequency of starts Risk of damage to the motor!</p> <ul style="list-style-type: none"> ▷ Never exceed the specified frequency of starts.



To prevent high temperature increases in the motor and excessive loads on the motor, seal elements and bearings, the frequency of starts shall not exceed 30 starts per hour.

6.2.2 Operation on the power supply network

	CAUTION
	<p>Wrong supply voltage Damage to the pump (set)!</p> <ul style="list-style-type: none"> ▷ The maximum permissible deviation in supply voltage is 10 % of the rated voltage indicated on the name plate. ▷ The maximum permissible voltage difference between the individual phases is 1 %.

6.2.3 Fluid handled

6.2.3.1 Permissible fluids to be handled

	<p style="background-color: #f4a460; padding: 5px;">⚠ WARNING</p> <p>Pumping of impermissible fluids Hazardous to persons and the environment!</p> <ul style="list-style-type: none"> ▷ Only discharge permissible fluids into the public sewer system. ▷ Check the suitability of pump/system materials.
	<p style="background-color: #f4d03f; padding: 5px;">CAUTION</p> <p>Unsuitable fluids Damage to the pump!</p> <ul style="list-style-type: none"> ▷ Never use the pump to handle corrosive, combustible or explosive fluids. ▷ Never use the pump to transport waste water from toilets and urinal systems. ▷ Do not use the pump for foodstuff applications.

Variant A (standard design)

- Chemically neutral waste water
- Slightly contaminated waste water (up to 40 °C max.)
- Wash water (up to 90 °C max. for short periods $t \leq 3$ minutes)

Free passage 10/11 mm:

- Solid particles with a particle size of up to 10 or 11 mm

Free passage 35 mm:

- Waste water containing long fibres and stringy material
- Solid particles with a particle size of up to 35 mm

Variant C for aggressive fluids

In addition to standard variant:

- Swimming pool water⁵⁾
- Brackish water
- Seawater
- Water containing salt
- Aggressive fluids
- Condensate from heat recovery applications

Variant R (for water containing oil / oil emulsions)

In addition to standard variant:

- Oil emulsions and cutting oils
- Waste water containing oil

5) Swimming pool water (0.4 to 1.4 mg/l free chlorine, max. 0.6 mg/l combined chlorine, pH 6.9 to 7.7, water hardness 10 to 30 °dH, max. salt content 7 g/l)

6.2.3.2 Minimum/maximum fluid level

Minimum level of fluid handled

	CAUTION
	<p>Fluid level below the specified minimum Damage to the pump set by cavitation!</p> <p>▷ Never allow the fluid level to drop below the specified minimum.</p>

The pump set is operational when the minimum fluid level is not lower than dimension W_T . This minimum fluid level must also be ensured during automatic operation.

Table 6: Minimum level of fluid handled

Type series	$W_{T\ min.}$
	[mm]
Ama-Drainer .../10	60
Ama-Drainer 522/11	120
Ama-Drainer 4..SD/35	120

Maximum fluid level (see name plate)

Max. immersion depth: 7 m

6.2.3.3 Temperature of the fluid handled

	CAUTION
	<p>Incorrect fluid temperature Damage to the pump (set)!</p> <p>▷ Only operate the pump (set) within the temperature limits indicated.</p>

Never operate the pump at temperatures exceeding the ones stated below.

- Pump (set) in submerged condition:
 - Maximum 40 °C
 - For a short time (up to 3 minutes) maximum 90 °C
- Pump (set) outside the fluid handled:
 - For limited time (up to 10 minutes) maximum 40 °C
 - For a short time (up to 3 minutes) maximum 90 °C

6.2.3.4 Density of the fluid handled

The power input of the pump set will change in proportion to the density of the fluid handled.

	CAUTION
	<p>Excessive density of the fluid handled Motor overload!</p> <p>▷ Observe the information on fluid density in the data sheet.</p> <p>▷ Make sure the motor has sufficient power reserves.</p>

The pump (set) is suitable for handling chemically neutral waste water not containing coarse substances, sand or faeces.

Table 7: Particle size for slightly contaminated waste water

Type series	Max. particle size
	[mm]
Ama-Drainer .../10	10
Ama-Drainer 522/11	11
Ama-Drainer 4..SD/35	35

6.3 Shutdown/storage/preservation

6.3.1 Measures to be taken for shutdown

	<p>! WARNING</p>
	<p>Unintentional starting of the pump set Risk of injury by moving components and shock currents!</p> <ul style="list-style-type: none"> ▷ Ensure that the pump set cannot be started unintentionally. ▷ Always make sure the electrical connections are disconnected before carrying out work on the pump set.
	<p>! WARNING</p>
	<p>Fluids handled, consumables and supplies which are hot and/or pose a health hazard Risk of injury!</p> <ul style="list-style-type: none"> ▷ Observe all relevant laws. ▷ When draining the fluid take appropriate measures to protect persons and the environment. ▷ Decontaminate pumps which handle fluids posing a health hazard.

1. Disconnect the pump from the power supply and protect it against start-up.
2. Wait until the pump has cooled down (10 minutes), then remove it.
3. Properly flush the pump.
Point the water jet on the pump's discharge nozzle.
4. Leave the pump to dry.
5. Store the pump vertically in a dark, dry and frost-proof room.

6.4 Returning to service









	<p>NOTE</p>
	<p>On pumps/pump sets older than 5 years we recommend replacing all elastomer seals.</p>

For returning the equipment to service, observe the sections on commissioning/start-up (⇒ Section 6.1, Page 25) and the operating limits (⇒ Section 6.2, Page 26) .

In addition carry out all servicing/maintenance operations before returning the pump set to service. (⇒ Section 7, Page 30) .

7 Servicing/Maintenance

7.1 Safety regulations



	 DANGER
	<p>Power supply not disconnected Danger to life!</p> <ul style="list-style-type: none"> ▸ Pull the mains plug and secure the pump against unintentional start-up.
	 DANGER
	<p>Work on the pump set by unqualified personnel Danger of death from electric shock!</p> <ul style="list-style-type: none"> ▸ Have pump components modified and dismantled by authorised personnel only.
	 WARNING
	<p>Insufficient stability Risk of crushing hands and feet!</p> <ul style="list-style-type: none"> ▸ During assembly/dismantling, secure the pump (set)/pump parts to prevent tilting or tipping over.
	 WARNING
	<p>Fluids handled, consumables and supplies posing a health hazard Hazard to persons and the environment!</p> <ul style="list-style-type: none"> ▸ Clean the pump prior to any maintenance and installation work. ▸ Make sure persons cannot come into contact with the fluid handled.

7.2 Servicing/inspection

The pump is practically maintenance-free.

It will suffice to clean the pump once a year and carry out visual inspections of the condition of the pump and supply line.

7.3 Drainage/disposal

	 WARNING
	<p>Fluids, consumables and supplies which are hot or pose a health hazard Hazard to persons and the environment!</p> <ul style="list-style-type: none"> ▸ Collect and properly dispose of flushing fluid and any residues of the fluid handled. ▸ Wear safety clothing and a protective mask, if required. ▸ Observe all legal regulations on the disposal of fluids posing a health hazard.

The pump will be automatically drained when it is taken out of the fluid handled.

Always flush and clean the pump before transporting it to the workshop. Provide a certificate of decontamination for the pump set.

7.4 Dismantling the pump set

	<p>⚠ WARNING</p>
	<p>Hot surface Risk of injury! ▷ Allow the pump set to cool down to ambient temperature.</p>

1. Remove the cover from the clamp tie bar.

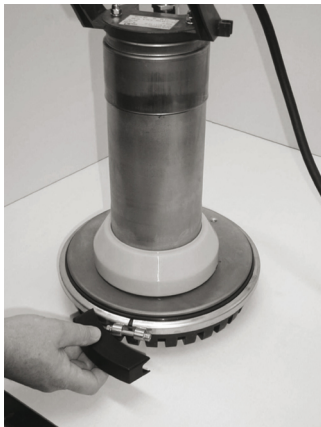

2. Undo screw 914.03 at the clamp tie bar.



3. Remove the clamp.



4. Pull out the volute casing.

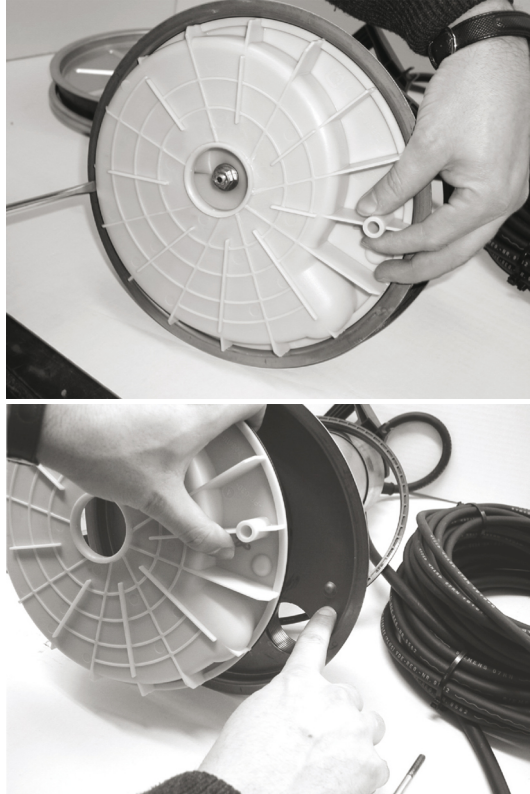

5. Clean all dismantled parts and check them for signs of wear.

7.5 Reassembling the pump set

- ✓ All parts have been cleaned and checked for wear.
- ✓ Any damaged or worn parts have been replaced by original spare parts.

1. Fit the volute casing.



2. Fit the clamp tie bar.



3. Insert and tighten screw 914.03 at the clamp tie bar.



4. Fit the cover on the clamp tie bar.

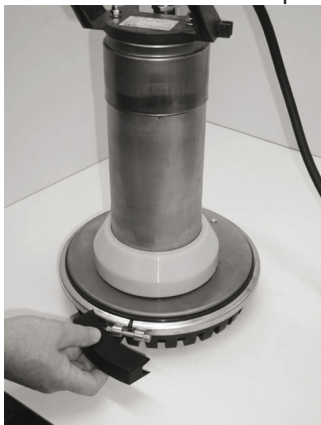

7.6 Tightening torques

Table 8: Tightening torques [Nm]

Part No.	Description	Tightening torque
		[Nm]
914.03	Hexagon socket head cap screw	6

7.7 Recommended spare parts stock

It is not necessary to keep spare parts on stock.

8 Trouble-shooting

	<p>! WARNING</p>
	<p>Improper work to remedy faults Risk of injury!</p> <p>▷ For any work performed to remedy faults, observe the relevant information given in this instruction manual and/or in the product literature provided by the accessories manufacturer.</p>
	<p>NOTE</p>
	<p>Please contact KSB Service before carrying out any work on the pump's internal parts during the warranty period. Non-compliance will lead to forfeiture of warranty cover and of any and all rights to claims for damages.</p>

- A Pump is running, but does not deliver
- B Insufficient flow rate
- C Excessive current/power input
- D Insufficient discharge head
- E Vibrations and noise during pump operation

Table 9: Trouble-shooting

A	B	C	D	E	Possible cause	Remedy ⁶⁾
-	X	-	-	-	Pump delivers against an excessively high pressure.	Open the shut-off valve to re-adjust to duty point.
-	X	-	-	-	Gate valve in the discharge line is not fully open.	Fully open the gate valve.
-	-	X	-	X	Pump running in off-design conditions (part load / overload)	Check the pump's operating data.
X	-	-	-	-	Pump or piping are not completely vented.	Clean vent hole 5 B in pump casing 101.
X	-	-	-	-	Pump intake clogged by deposits	Clean the intake, pump components and lift check valve.
-	X	-	X	X	Supply line or impeller clogged	Remove deposits in the pump and/or piping.
-	-	X	-	X	Dirt/fibres in the clearance between the casing wall and impeller; sluggish rotor.	Check whether the impeller can be easily rotated; clean the hydraulic system, if required.
-	X	X	X	X	Wear of internal components	Replace worn components by new ones.
X	X	-	X	-	Defective riser (pipe and sealing element)	Replace defective riser pipes and sealing elements.
-	X	-	X	X	Impermissible air or gas content in the fluid handled	Contact the manufacturer.
-	X	X	X	X	Wrong direction of rotation	If the pump set is running in the wrong direction of rotation, check the electrical connection and the control system, if necessary.
-	-	X	-	-	Operating voltage is too low.	Check mains voltage. Check cable connections.
X	-	-	-	-	Motor is not running because of lack of voltage.	Check electrical installation, inform electric utility company.
X	X	-	X	-	Motor is running on 2 phases only.	Replace the defective fuse. Check the electrical cable connections.
X	-	-	-	-	Motor winding or electric cable are defective.	Contact KSB's pump service.
-	-	X	-	X	Defective radial bearing in the motor	Contact the manufacturer.

6) The pump pressure must be released before attempting to remedy faults on parts which are subjected to pressure. Disconnect the pump from the power supply and let it cool down before working on it.

A	B	C	D	E	Possible cause	Remedy ⁶⁾
-	X	X	-	-	Pump clogged by sand, dirt in the pump sump, insufficient inflow	Clean the intake, strainer, pump components and check valve; drain and clean the pump sump.
X	-	-	-	-	Temperature control device monitoring the winding has tripped the pump as a result of excessive winding temperatures.	The motor will restart automatically once the pump set has cooled down.

9 Related Documents

9.1 General assembly drawing with list of components

9.1.1 General assembly drawing of Ama-Drainer .../10, .../10K, .../35

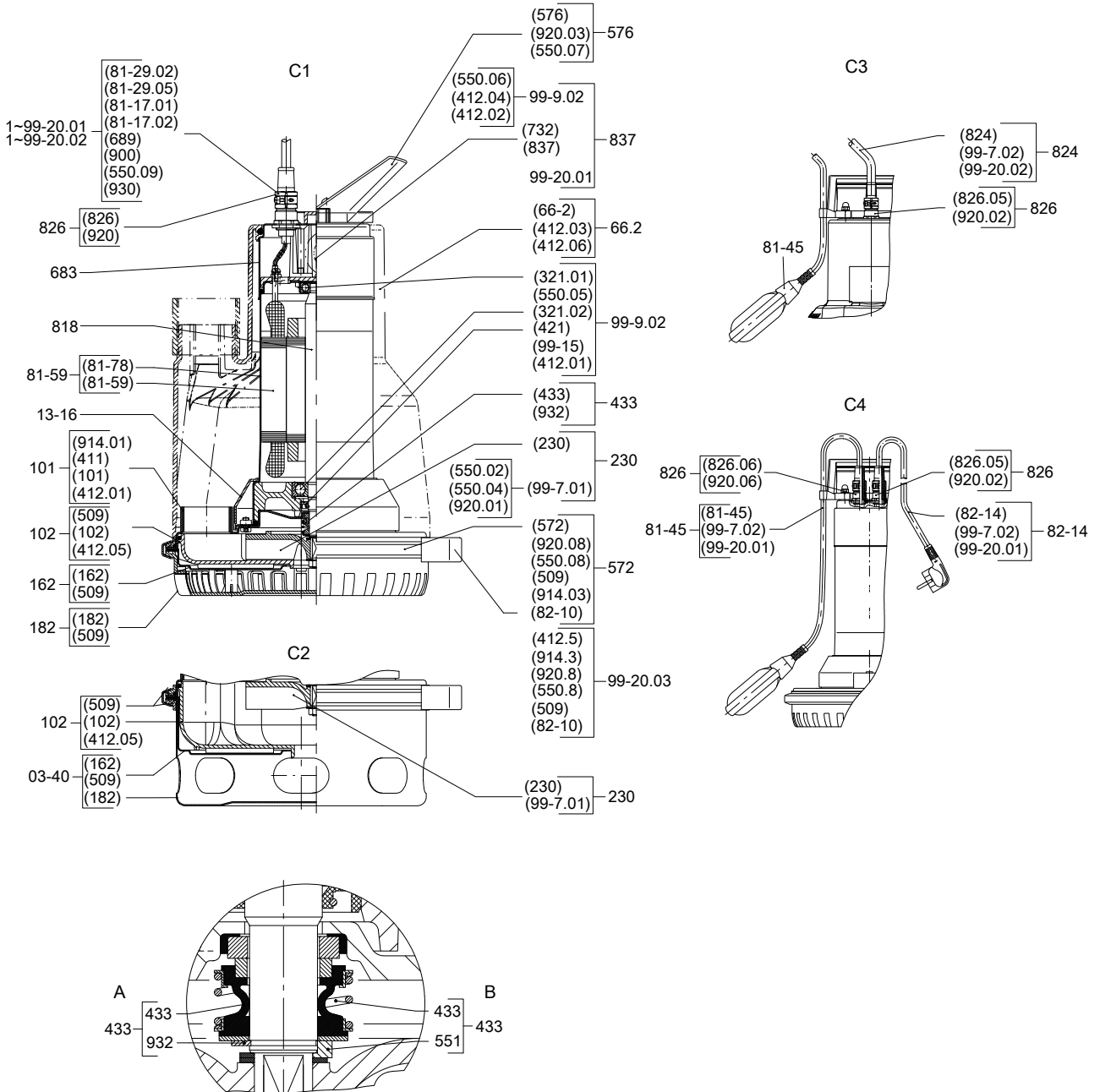

Fig. 6: General assembly drawing of Ama-Drainer .../10, .../10K, .../35

A	Ama-Drainer A / R	B	Ama-Drainer C
C1	Ama-Drainer .../10, .../10K, ... /35	C2	Ama-Drainer SD
C3	Ama-Drainer .../35	C4	Ama-Drainer SE

Table 10: List of components

Part No.	Description	Comprises:
03-40	Foot / suction cover assembly (for .../35)	Suction cover 162
		Foot 182
		Intermediate ring 509

2331.826/11-EN

Part No.	Description	Comprises:
101	Pump casing, complete	Pump casing [101] Joint ring 411 O-ring 412.01 Hexagon socket head cap screw 914.01
102	Volute casing	Volute casing 102 O-ring 412.05 Intermediate ring 509
13-16	Protective casing	Protective casing 13-16
162	Suction cover	Suction cover 162 Intermediate ring 509
182	Pump foot	Foot 182 Intermediate ring 509
230	Impeller, complete	Impeller 230 Impeller installation kit 99-7.01
433	Mechanical seal, complete	Mechanical seal (433) Spacer disc 551 (for variant C only) Circlip 932
572	Clamp, complete	Clamp 572 Intermediate ring 509 Disc 550.08 Cover strip 82-10 Hexagon socket head cap screw 914.03 Nut 920.08
576	Handle, complete	Handle 576 Disc 550.07 Nut 920.03 Plate 970
66-2	Cooling jacket, set of accessories	Cooling jacket 66-2 O-ring 412.03/.06
683	Hood	Hood 683
81-45	Float switch (single-phase units)	Float switch (6 A / 0.5 m) 81-45 Float switch (10 A / 0.5 m) 81-45 Repair kit for cable (single-phase) 99-20.01 Installation kit for hood 99-7.02
81-45	Float switch (three-phase units)	Float switch (6 A / 10 m) 81-45
81-59	Stator, complete	Stator [81-59] Stator case 81-78
818	Pump rotor	Pump rotor 818
82-14	Cable with plug (single-phase units)	Cable with plug (3×1 mm ² , length 10 m) 82-14 Repair kit for cable (single-phase) 99-20.01 Installation kit for hood 99-7.02
824	Cable (three-phase units)	Cable (6×1 mm ² , length 10 m) 824 Repair kit 99-20.02 Installation kit for hood 99-7.02
826	Cable gland	Cable gland 826 Nut (M20x1.5) 920.05
837	Capacitor (single-phase units only)	Capacitor 837 Capacitor holder 732 Repair kit for cable (single-phase) 99-20.01

Part No.	Description	Comprises:
837	Capacitor (single-phase units only)	Installation kit for hood 99-7.02
99-7.01	Impeller installation kit	Adjusting washer 550.02
		Disc 550.04
		Nut 920.01
99-7.02	Installation kit for hood	O-ring 412.02/.04
		Disc 550.06
99-11	Bearing	Deep groove ball bearing 321.01/.02
		O-ring 412.01
		Shaft seal ring 421
		Disc 550.05
		Lubricating oil 99-15
99-20.01/.02	Cable repair kit	Insulation tube 689
		Disc 550.09
		End connector 81-17.01/.02
		Terminal 81-29.02
		Screw 900
		Serrated lock washer 930
99-20.03	Hydraulic system repair kit	O-ring 412.05
		Intermediate ring 509
		Disc 550.08
		Cover strip 82-10
		Hexagon socket head cap screw 914.03
		Nut 920.08

9.1.2 General assembly drawing Ama-Drainer 522/11

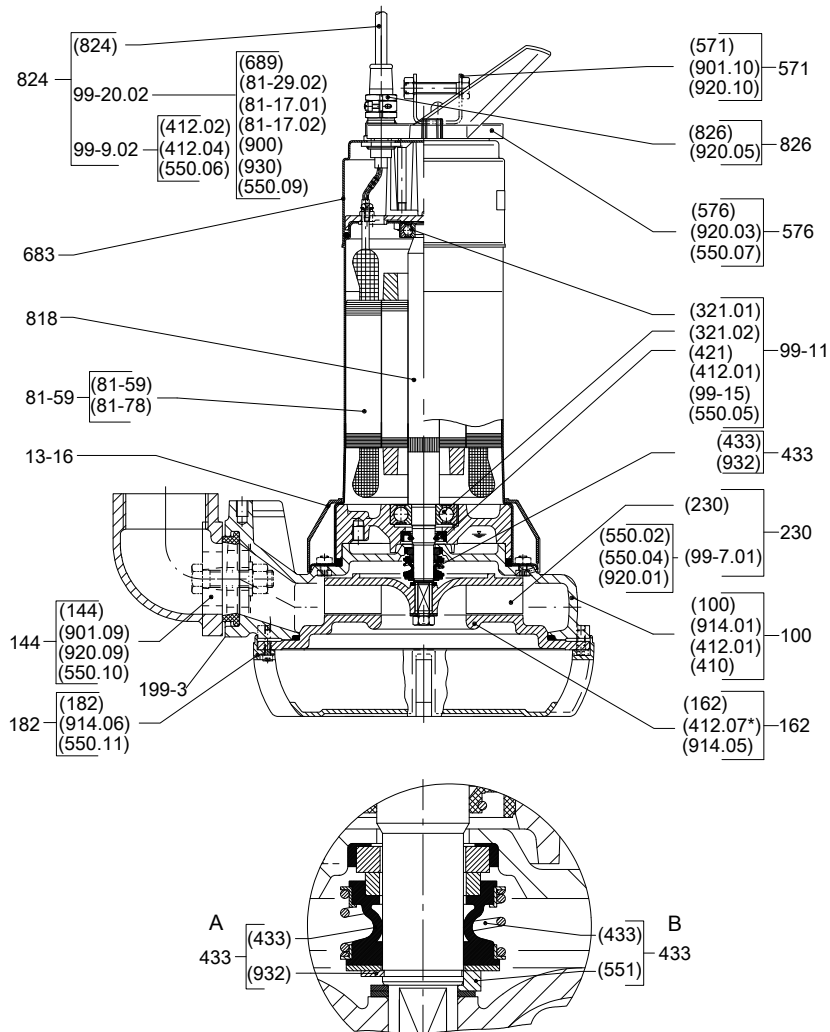

Fig. 7: General assembly drawing of Ama-Drainer 522/11

A	Ama-Drainer A / R	B	Ama-Drainer C
---	-------------------	---	---------------

Table 11: List of components

Part No.	Description	Comprises:
100	Casing, complete	Casing 100 Profile seal 410 O-ring 412.01 Hexagon socket head cap screw 914.01
144	Discharge elbow, complete	Discharge elbow 144 Disc 550.10 Hexagon head bolt 901.09 Nut 920.09
13-16	Protective casing	Protective casing 13-16
162	Suction cover	Suction cover 162 O-ring 412.07 Hexagon socket head cap screw 914.05
182	Pump foot	Foot 182 Disc 550.11 Hexagon socket head cap screw 914.06

Part No.	Description	Comprises:
199-3	Flange adapter ⁷⁾	Flange adapter (DN 50) 182.5 Profile seal 410.02 Disc 550.12 Stud 902.01
230	Impeller, complete	Impeller 230 Impeller installation kit 99-7.01
433	Mechanical seal, complete	Mechanical seal 433 Spacer disc 551 (for variant C only) Circlip 932
571	Bracket, complete	Bracket 571 Hexagon head bolt 901.10 Hexagon nut 920.10
576	Handle, complete	Handle 576 Disc 550.07 Nut 920.03
683	Hood	Hood 683
81-45	Float switch (three-phase units)	Float switch (6 A / 10 m) 81-45
81-59	Stator, complete	Stator 81-59 Stator case 81-78
818	Pump rotor	Pump rotor 818
824	Cable (three-phase units)	Cable (6×1mm ² , length 10 m) 824 Installation kit for hood 99-7.02 Repair kit 99-20.02
826	Cable gland	Cable gland 826 Nut (M20×1.5) 920.05
99-7.01	Impeller installation kit	Adjusting washer 550.02 Disc 550.04 Nut 920.01
99-7.02	Installation kit for hood	O-ring 412.02/.04 Disc 550.06
99-11	Bearing	Deep groove ball bearing 321.01/.02 O-ring 412.01 Shaft seal ring 421 Disc 550.05 Lubricating oil 99-15
99-20.02	Cable repair kit	Insulation tube 689 Disc 550.09 End connector 81-17.01/.02 Terminal 81-29.02 Screw 900 Serrated lock washer 930
99-20.03	Hydraulic system repair kit	O-ring 412.05 Intermediate ring 509 Disc 550.08 Cover strip 82-10 Hexagon socket head cap screw 914.03 Nut 920.08

2331.826/11-EN

7) Not shown in drawing

9.2 Dimensions and connections

9.2.1 Single pumps

9.2.1.1 Ama-Drainer 4..SE/10

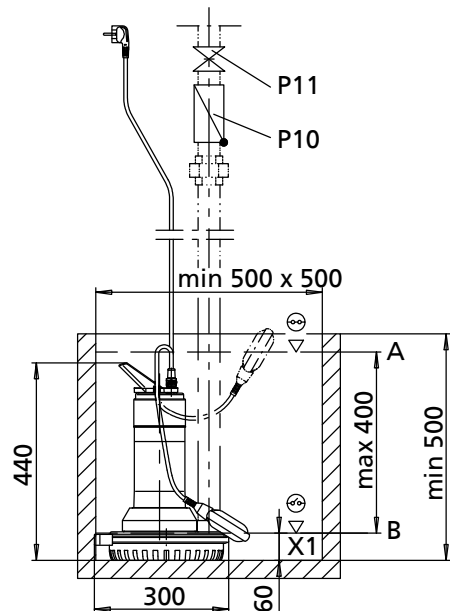

Fig. 8: Outline drawing Ama-Drainer 4..SE/10 without cooling jacket

A	Start-up level
B	Stop level
P 10	Swing check valve
P11	Gate valve
X1	Residual water level

9.2.1.2 Ama-Drainer 5..SD/10 K

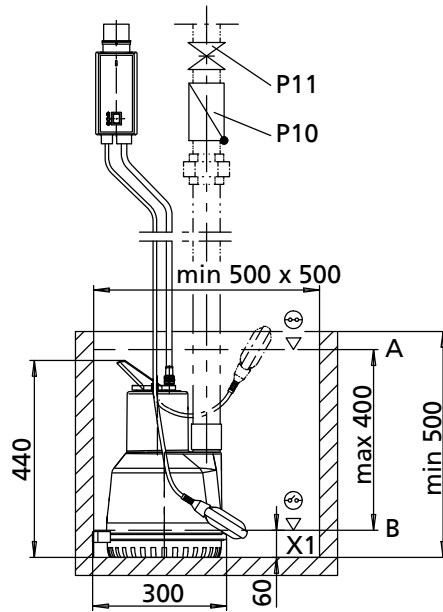

Fig. 9: Outline drawing Ama-Drainer 5..SD/10 K with cooling jacket

A	Start-up level
B	Stop level
P 10	Swing check valve
P11	Gate valve
X1	Residual water level

9.2.1.3 Ama-Drainer 4..SD/35

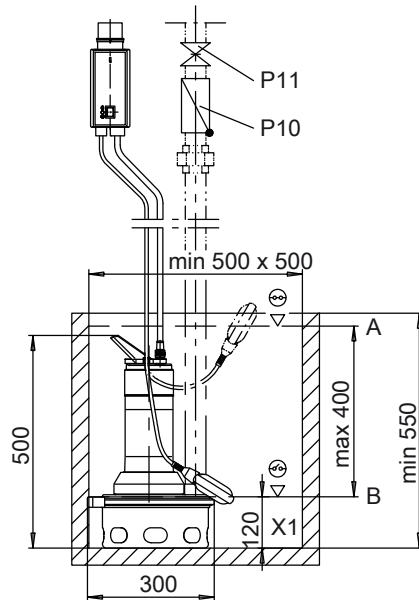

Fig. 10: Outline drawing Ama-Drainer 4..SD/35 without cooling jacket

A	Start-up level
B	Stop level
P 10	Swing check valve

2331.826/11-EN

P11	Gate valve
X1	Residual water level

9.2.1.4 Ama-Drainer 522/11

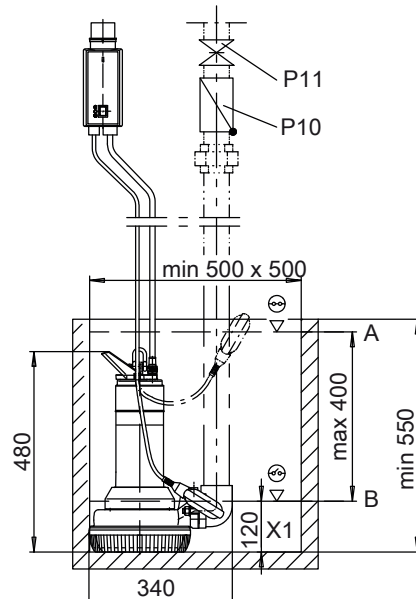

Fig. 11: Outline drawing Ama-Drainer 522/11 without cooling jacket

A	Start-up level
B	Stop level
P 10	Swing check valve
P 11	Gate valve
X1	Residual water level

9.2.2 Examples of transportable models

9.2.2.1 Ama-Drainer 4..NE/10

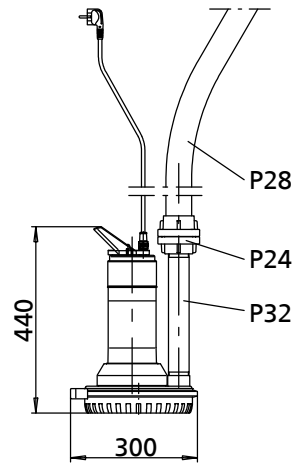

Fig. 12: Outline drawing Ama-Drainer 4..NE/10 without cooling jacket

P 24	Storz rigid coupling
P 28	Plastic hose
P 32	Pipe extension

9.2.2.2 Ama-Drainer 5..NE/10 K

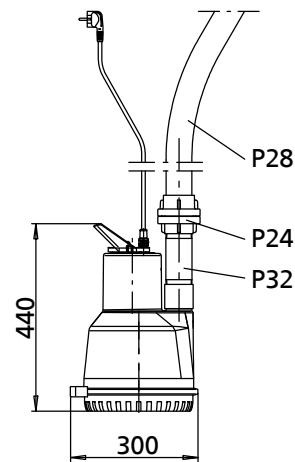

Fig. 13: Outline drawing Ama-Drainer 5..NE/10 K with cooling jacket

P 24	Storz rigid coupling
P 28	Plastic hose
P 32	Pipe extension

9.2.2.3 Ama-Drainer 522 ND/11

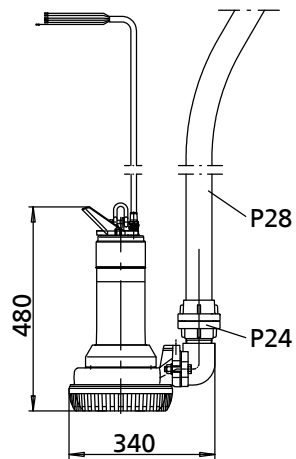

Fig. 14: Outline drawing Ama-Drainer 522 ND/11 without cooling jacket

P 24	Storz rigid coupling
P 28	Plastic hose

9.2.3 Examples of stationary installation

9.2.3.1 Ama-Drainer 522 ND/11 with guide hoop

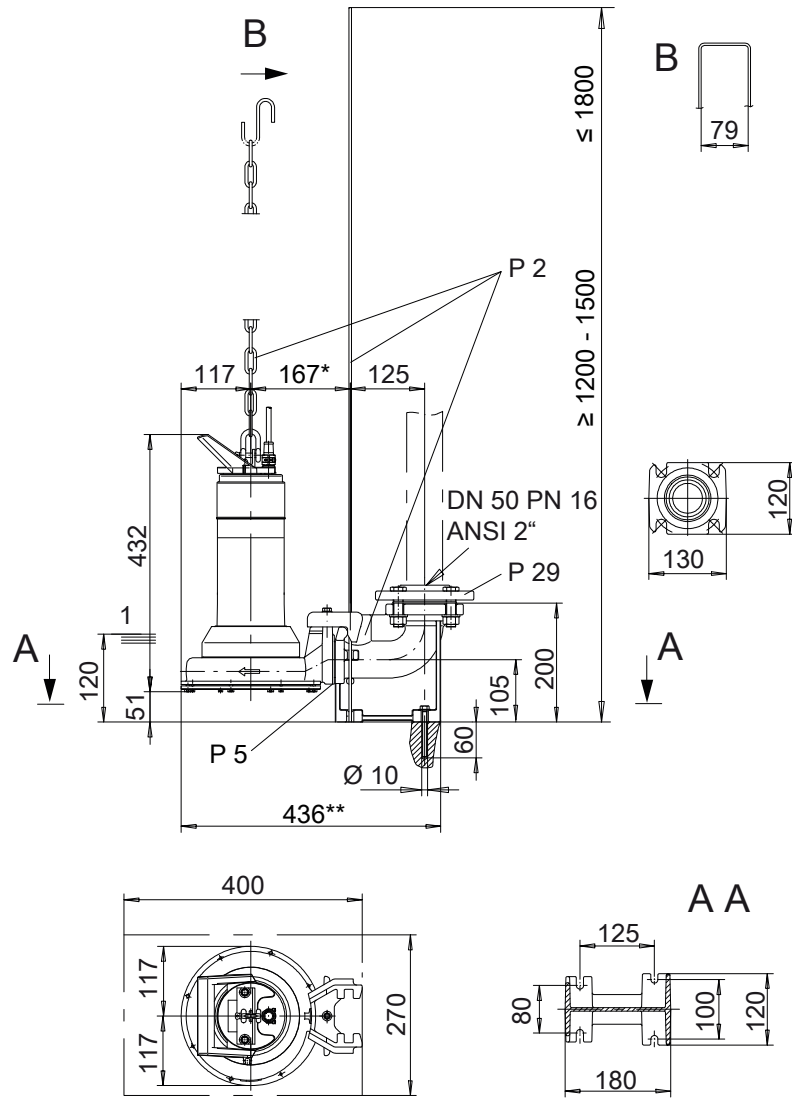

Fig. 15: Outline drawing Ama-Drainer 522 ND/11 with guide hoop

*	When using flange adapter P 5: 217 mm
**	When using flange adapter P 5: 486 mm

Table 12: Overview of connections

Connection	Description
1	Lowest stop level for automatic operation
P 2	Guide hoop arrangement
P 5 ⁸⁾	Flange adapter for stabilising the pump position during start-up
P 29	Threaded flange

2331.826/11-EN

8) Not shown in drawing

9.2.3.2 Ama-Drainer 522 ND/11 with guide wire

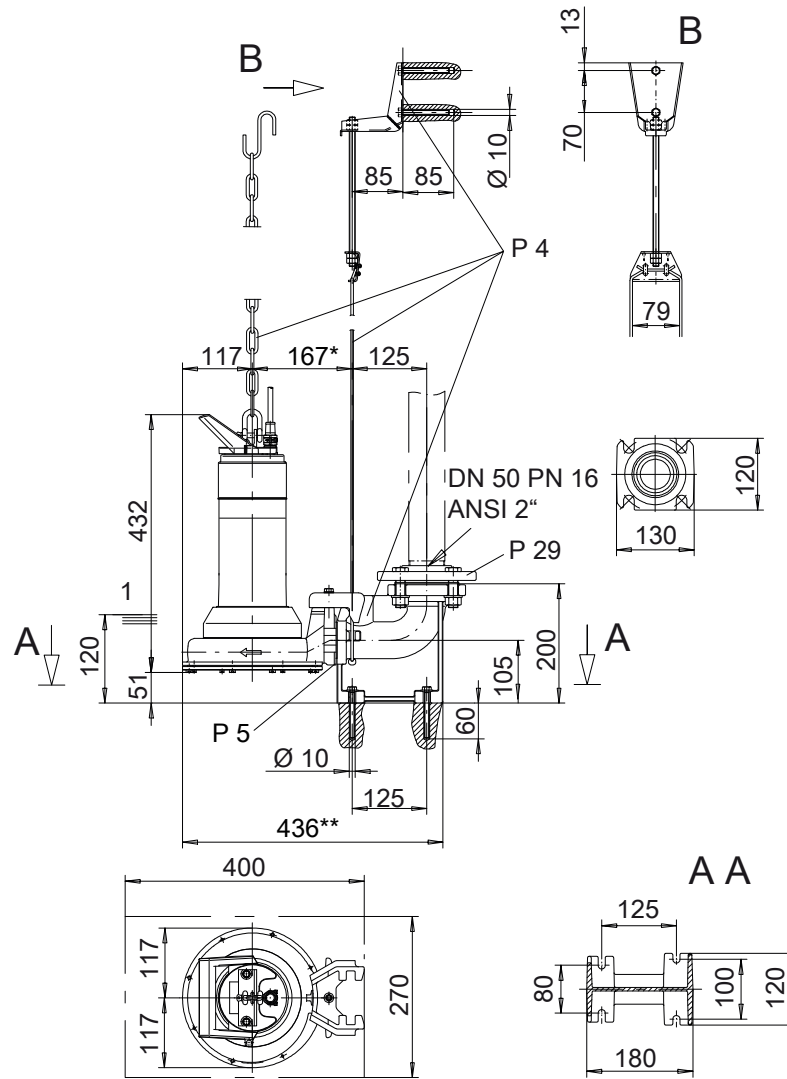

Fig. 16: Outline drawing Ama-Drainer 522 ND/11 with guide wire

*	When using flange adapter P 5: 217 mm
**	When using flange adapter P 5: 486 mm

Table 13: Overview of connections

Connection	Description
1	Lowest stop level for automatic operation
P 4	Guide wire arrangement
P 5 ⁹⁾	Flange adapter for stabilising the pump position during start-up
P 29	Threaded flange

9) Not shown in drawing

9.2.4 Installation example of a dual-pump station

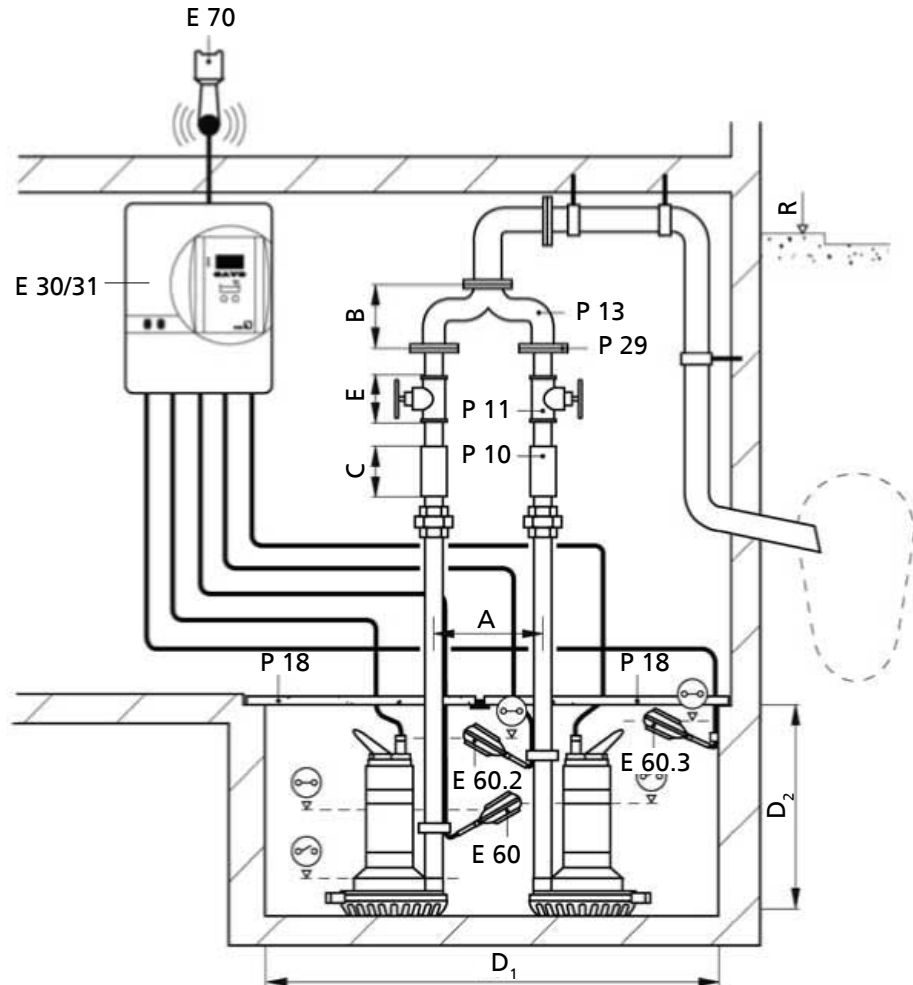

Fig. 17: Position of float switches in a dual-pump station

P 10	Swing check valve
P 11	Gate valve
P 13	Y-pipe
P 18	Cover plate
P 29	Threaded flange
E 5	AS 5 alarm switchgear
E 5/2	Horn
E 12 / E 13	Control unit
E 14	Float switch, normal water level
E 14/2	Float switch, high water level
E 14/3	Alarm contactor
R	Flood level

Table 14: Dimensions and weights

Size	A	B	C	D ₁	D ₂	E	[kg]
	[mm]	[mm]	[mm]	[mm]	[mm]	[mm]	
Ama-Drainer 4..SE/10	275	190	130	1060 x 500	500	55	16
Ama-Drainer 4..SD/35	275	190	130	1060 x 500	500	60	17
Ama-Drainer 5..SD/10 K	300	210	130	1060 x 500	500	55	17
Ama-Drainer 522/11	300	210	130	1060 x 500	500	55	24

9.3 Wiring diagrams

9.3.1 Ama-Drainer SE

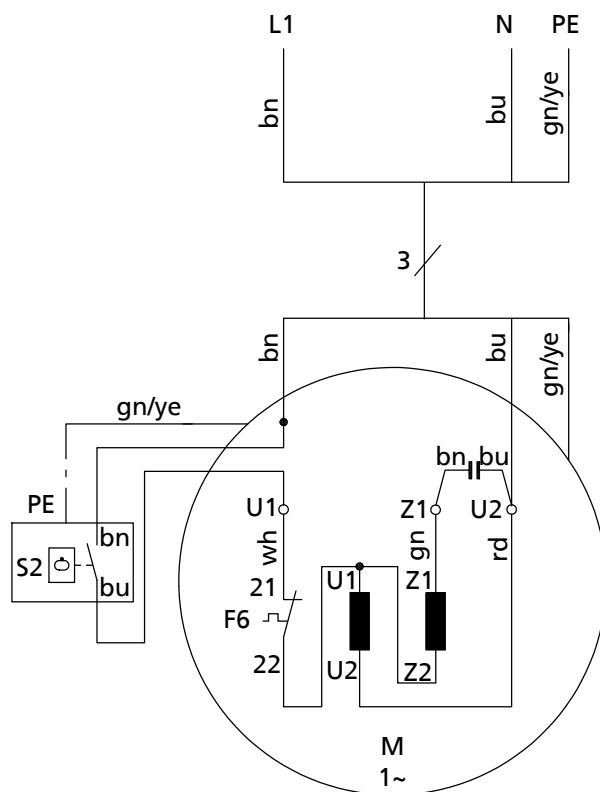

Fig. 18: Wiring diagram Ama-Drainer SE

F6	Bimetal switch
M	Motor
S2	Float switch
bu	blue
bn	brown
rd	red
wh	white
gn/ye	green/yellow
gn	green

9.3.2 Ama-Drainer NE

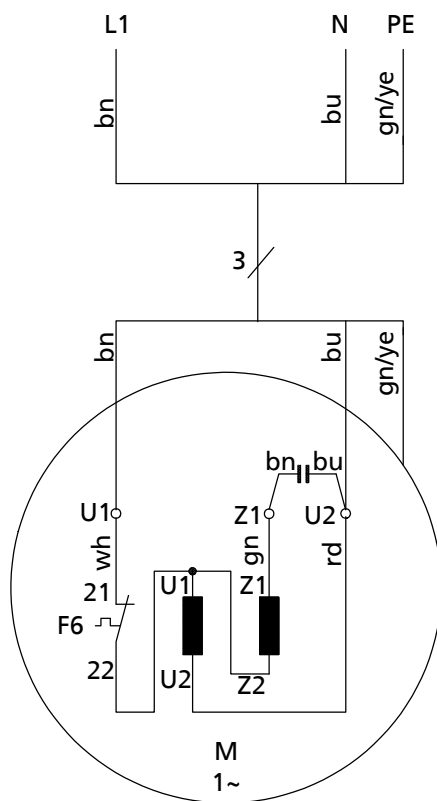

Fig. 19: Wiring diagram Ama-Drainer NE

F6	Bimetal switch
M	Motor
bu	blue
bn	brown
rd	red
wh	white
gn/ye	green/yellow
gn	green

9.3.3 Ama-Drainer SD

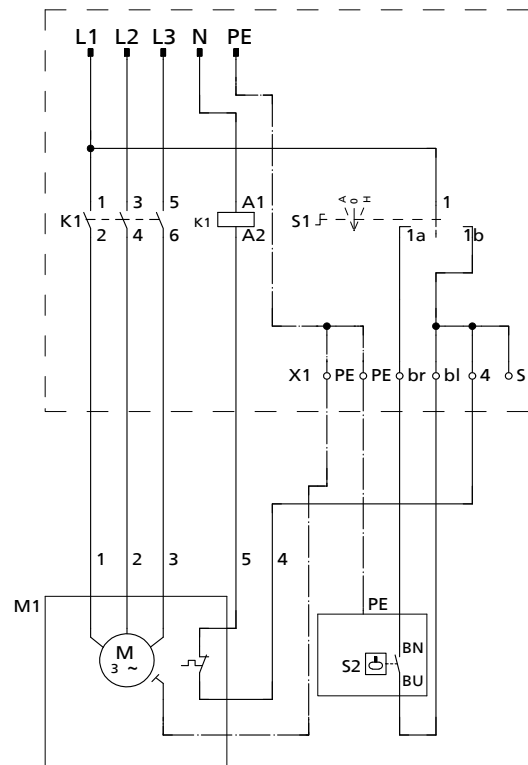

Fig. 20: Wiring diagram Ama-Drainer SD

K1	Contactor
S1	Manual-0-automatic selector switch
X1	Terminal strip
M1	Motor
S2	Float switch
bu	blue
bn	brown

9.3.4 Ama-Drainer ND

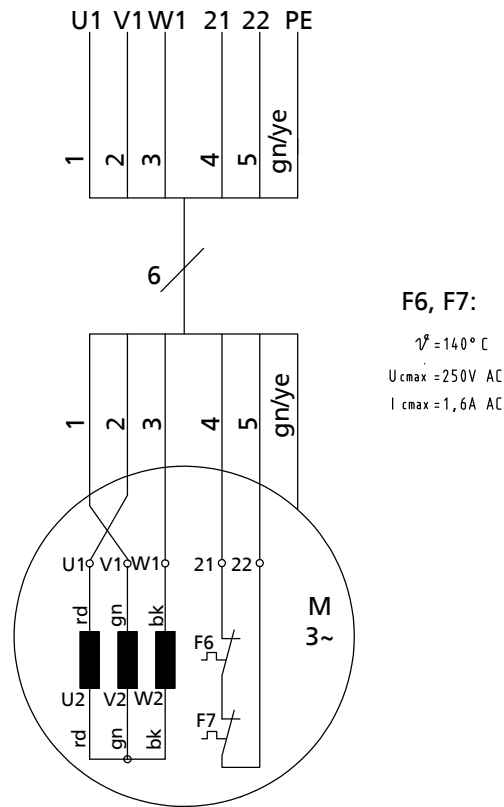

Fig. 21: Wiring diagram Ama-Drainer ND

F6/F7	Bimetal switch
M	Motor
bk	black
gn	green
rd	red
gn/ye	green/yellow

10 EU Declaration of Conformity

Manufacturer: **KSB SE & Co. KGaA**
Johann-Klein-Straße 9
67227 Frankenthal (Germany)

The manufacturer herewith declares that the product:

**Ama-Drainer 405 _E/10, 407 _E/10, 411 _E/10, 415 _E/10, 422
_E/10**
**Ama-Drainer 505 _E/10 K, 507 _E/10 K, 511 _E/10 K, 515 _E/10 K,
522 _E/10 K**
Ama-Drainer 405 _E/35, 411 _E/35, 422 _E/35
Ama-Drainer 522 _E/11

Serial number range: S2001-S2452

- is in conformity with the provisions of the following Directives as amended from time to time:
 - Pump set: 2006/42/EC Machinery Directive
 - Electrical components¹⁰⁾: 2011/65/EU Restriction of the use of certain hazardous substances in electrical and electronic equipment (RoHS)
 - 2014/30/EU: Electromagnetic Compatibility (EMC)

The manufacturer also declares that

- the following harmonised international standards have been applied:
 - ISO 12100
 - EN 809
 - EN 60034-1, EN 60034-5/A1
 - EN 60335-1/A1, EN 60335-2-41

Person authorised to compile the technical file:

Hugues Roland
Head of Design/Engineering
KSB S.A.S.
128, rue Carnot,
59320 Sequedin (France)

The EU Declaration of Conformity was issued in/on:

Frankenthal, 1 January 2020



Thomas Heng
Head of Product Development Series Pumps
KSB SE & Co. KGaA
Johann-Klein-Straße 9
67227 Frankenthal

10) Where applicable

11 EU Declaration of Conformity

Manufacturer: **KSB SE & Co. KGaA**
Johann-Klein-Straße 9
67227 Frankenthal (Germany)

The manufacturer herewith declares that the product:

**Ama-Drainer 405 _D/10, 407 _D/10, 411 _D/10, 415 _D/10, 422
_D/10**
**Ama-Drainer 505 _D/10 K, 507 _D/10 K, 511 _D/10 K, 515 _D/10
K, 522 _D/10 K**
Ama-Drainer 405 _D/35, 411 _D/35, 422 _D/35
Ama-Drainer 522 _D/11

Serial number range: S2001-S2452

- is in conformity with the provisions of the following Directives as amended from time to time:
 - Pump set: 2006/42/EC Machinery Directive
 - Electrical components¹¹⁾: 2011/65/EU Restriction of the use of certain hazardous substances in electrical and electronic equipment (RoHS)
 - 2014/30/EU: Electromagnetic Compatibility (EMC)

The manufacturer also declares that

- the following harmonised international standards have been applied:
 - ISO 12100
 - EN 809
 - EN 60034-1, EN 60034-5/A1

Person authorised to compile the technical file:

Hugues Roland
Head of Design/Engineering
KSB S.A.S.
128, rue Carnot,
59320 Sequedin (France)

The EU Declaration of Conformity was issued in/on:

Frankenthal, 1 January 2020

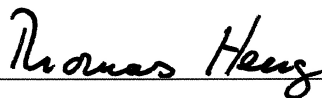

Thomas Heng
Head of Product Development Series Pumps
KSB SE & Co. KGaA
Johann-Klein-Straße 9
67227 Frankenthal

11) Where applicable

12 Certificate of Decontamination

Type:

Order number/

Order item number¹²⁾:

Delivery date:

Applications:

Fluid handled¹²⁾:

Please tick where applicable¹²⁾:

<input type="checkbox"/>		<input type="checkbox"/>		<input type="checkbox"/>		<input type="checkbox"/>		<input type="checkbox"/>	
	Corrosive		Oxidising		Flammable		Explosive		Hazardous to health
<input type="checkbox"/>		<input type="checkbox"/>		<input type="checkbox"/>		<input type="checkbox"/>		<input checked="" type="checkbox"/>	
	Seriously hazardous to health		Toxic		Radioactive		Bio-hazardous		Safe

Reason for return¹²⁾:

Comments:

The product/accessories have been carefully drained, cleaned and decontaminated inside and outside prior to dispatch/placing at your disposal.

We herewith declare that this product is free from hazardous chemicals, biological and radioactive substances.

For mag-drive pumps, the inner rotor unit (impeller, casing cover, bearing ring carrier, plain bearing, inner rotor) has been removed from the pump and cleaned. In cases of containment shroud leakage, the outer rotor, bearing bracket lantern, leakage barrier and bearing bracket or intermediate piece have also been cleaned.

For canned motor pumps, the rotor and plain bearing have been removed from the pump for cleaning. In cases of leakage at the stator can, the stator space has been examined for fluid leakage; if fluid handled has penetrated the stator space, it has been removed.

- No special safety precautions are required for further handling.
- The following safety precautions are required for flushing fluids, fluid residues and disposal:

.....

.....

We confirm that the above data and information are correct and complete and that dispatch is effected in accordance with the relevant legal provisions.

.....

Place, date and signature	Address	Company stamp
---------------------------	---------	---------------

12) Required fields

Index

B

Bearings 16

C

Certificate of Decontamination 56

Commissioning 25

Commissioning/start-up 25

D

Design 15

Designation 14

Disposal 12

Drive 15

E

Electrical connection 23

Event of damage 6

Explosion protection 23

F

Faults

Causes and remedies 35

Fields of application 8

Fluid handled

Density 28

I

Impeller type 16

Installation 15

Installation at site 19

Intended use 8

K

Key to safety symbols/markings 7

L

Level control system 22

N

Name plate 15

O

Other applicable documents 6

Overload protection 22

P

Partly completed machinery 6

R

Return to supplier 11

Returning to service 29

S

Safety 8

Safety awareness 9

Scope of supply 18

Shaft seal 16

Shutdown 29

Start-up 25

Stopping 25

T

Tightening torques 34

Transport 11

W

Warnings 7

Warranty claims 6



KSB SE & Co. KGaA

Johann-Klein-Straße 9 • 67227 Frankenthal (Germany)

Tel. +49 6233 86-0

www.ksb.com

2331.826/11-EN (01442616)