

Closed-coupled Pump

# Etachrom B

Fixed Speed / Variable Speed  
50 Hz / 60 Hz

## Type Series Booklet



## **Legal information/Copyright**

Type Series Booklet Etachrom B

All rights reserved. The contents provided herein must neither be distributed, copied, reproduced, edited or processed for any other purpose, nor otherwise transmitted, published or made available to a third party without the manufacturer's express written consent.

Subject to technical modification without prior notice.

© KSB SE & Co. KGaA, Frankenthal 2023-05-10

## Contents

<b>Standardised Pumps / Close-coupled Pumps .....</b>	<b>5</b>
Close-coupled Pumps .....	5
Etachrom B .....	5
Main applications .....	5
Fluids handled .....	5
Related documents .....	5
Operating data .....	5
Design details .....	6
Designation .....	8
Materials .....	9
Coating and preservation .....	10
Product benefits .....	10
Product information .....	10
Product information as per Regulation No. 1907/2006 (REACH) .....	10
Product information as per Regulation No. 547/2012 (for water pumps with a maximum shaft power of 150 kW) implementing "Ecodesign" Directive 2009/125/EC .....	10
Certifications .....	10
Acceptance tests and warranty .....	10
Overview of product features / selection tables .....	11
Overview of fluids handled .....	11
Impellers .....	14
Pressure limits and temperature limits .....	14
Technical data .....	15
Etachrom B .....	15
Etachrom B, n = 2900 rpm / n = 3500 rpm .....	16
Etachrom B, n = 1450 rpm / n = 1750 rpm .....	19
Maximum permissible P/n value / maximum permissible speed .....	21
Axial mass moment of inertia .....	21
Liquid fill of pump .....	22
Permissible forces and moments at the pump nozzles .....	23
Noise characteristics .....	24
Mechanical seal design .....	25
Additional information .....	25
Selection charts .....	27
Etachrom B, n = 2900 rpm .....	27
Etachrom B, n = 1450 rpm .....	27
Etachrom B, n = 3500 rpm .....	28
Etachrom B, n = 1750 rpm .....	28
Dimensions and weights .....	29
Etachrom B 25, up to motor 112 (4.00 kW), with pump foot .....	29
Etachrom B 32, up to motor 112 (4.00 kW), with pump foot .....	31
Etachrom B 40, up to motor 112 (4.00 kW), with pump foot .....	33
Etachrom B 50, up to motor 112 (4.00 kW), with pump foot .....	34
Etachrom B 65, up to motor 112 (4.00 kW), with pump foot .....	35
Etachrom B 80, up to motor 112 (4.00 kW), with pump foot .....	36
Etachrom B 25, with levelling feet and motor shroud .....	37
Etachrom B 32, with levelling feet and motor shroud .....	39
Etachrom B 40, with levelling feet and motor shroud .....	41
Etachrom B 50, with levelling feet and motor shroud .....	43
Etachrom B 65, with levelling feet and motor shroud .....	46
Etachrom B 80, with levelling feet and motor shroud .....	48
Etachrom B 25, from motor 132 (5.50 kW), with motor foot .....	50
Etachrom B 32, from motor 132 (5.50 kW), with motor foot .....	51
Etachrom B 40, from motor 132 (5.50 kW), with motor foot .....	52
Etachrom B 50, from motor 132 (5.50 kW), with motor foot .....	53
Etachrom B 65, from motor 132 (5.50 kW), with motor foot .....	54
Etachrom B 80, from motor 132 (5.50 kW), with motor foot .....	55
Etachrom B 25, with ball feet .....	56
Etachrom B 32, with ball feet .....	58
Etachrom B 40, with ball feet .....	60
Etachrom B 50, with ball feet .....	62
Etachrom B 65, with ball feet .....	65

---

Etachrom B 80, with ball feet.....	67
Using PumpMeter .....	69
Pump component weights.....	70
Flange design (stainless steel to EN 1092-1).....	71
Installation types.....	72
Interchangeability of Etachrom B and Etachrom L pump components.....	74
Recommended spare parts stock for 2 years' operation to DIN 24296.....	75

## Standardised Pumps / Close-coupled Pumps

### Close-coupled Pumps

## Etachrom B

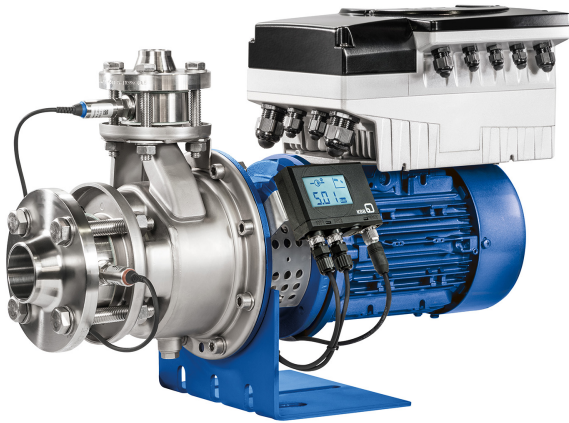

The product illustrated as an example may include options incurring a surcharge.

### Main applications

- Cleaning systems (bottle rinsing, crate washing and similar systems)
- Water treatment systems
- Water supply systems
- Fire-fighting systems
- Spray irrigation systems
- General irrigation systems
- Drainage systems
- Hot-water heating systems
- Air-conditioning systems
- Industrial washing machines
- General industry
- Disposal of paint sludge
- Surface treatment systems

### Fluids handled

- Service water
- Drinking water
- Hot water
- Cooling water
- Swimming pool water<sup>1)</sup>
- Process water

- Fire-fighting water
- Condensate
- Oil

### Related documents

Table 1: Information/documents

Document	Reference number
Characteristic curves booklet (50 Hz/60 Hz)	1212.56
Fixed speed version	
Characteristic curves booklet	1212.57
Variable speed version	
Type series booklet	4074.5
PumpDrive 2 / PumpDrive 2 Eco	

### Operating data

Table 2: Operating properties

Characteristic		Value	
		50 Hz	60 Hz
Flow rate	Q [m <sup>3</sup> /h]	≤ 260	≤ 210
	Q [l/s]	≤ 72,2	≤ 58,3
Head	H [m]	≤ 105	≤ 104
Fluid temperature	T [°C]	≥ -30	≥ -30
		≤ +110	≤ +110
Operating pressure	p [bar]	≤ 12 <sup>2)</sup>	≤ 12

<sup>1</sup> Swimming pool water (0.4 to 1.4 mg/l free chlorine, combined chlorine ≤ 0.6 mg/l, pH 6.9 to 7.7, water hardness 10 to 30 °dH, salt content ≤ 7 g/l)

<sup>2</sup> The sum of inlet pressure and shut-off head must not exceed the value indicated.

## Design details

### Design

- Design with materials to Regulation (EC) No. 1935/2004 can be provided.
- Design to ATEX

### Design

- Circular casing pumps
- Close-coupled design
- Back pull-out design
- Flanges to EN 1092-1
- Horizontal installation
- Single-stage
- Dimensions and ratings to EN 733
- Rigid connection between pump and motor
- Pump and motor connected by a stub shaft
- Fixed speed version (without PumpDrive 2 / PumpDrive 2 Eco / PumpDrive R) / variable speed version (with PumpDrive 2 / PumpDrive 2 Eco / PumpDrive R)

### Pump casing

- Circular casing
- Replaceable casing wear rings

### Installation

- Pump foot
- Motor foot
- Foot base with vertically adjustable ball feet
- Foot base with vertically adjustable machine mounts

### Drive (fixed speed version)

#### Standard design:

- KSB/Siemens surface-cooled IEC frame three-phase squirrel-cage motor
- Efficiency class IE2 (size 71/80) / IE3 (from size 90) to IEC 60034-30
- Rated voltage (50 Hz) 230 V / 400 V  $\leq$  2.20 kW
- Rated voltage (50 Hz) 400 V / 690 V  $\geq$  3.00 kW
- Rated voltage (60 Hz) - / 460 V  $\leq$  2.20 kW
- Rated voltage (60 Hz) 460 V / -  $\geq$  3.00 kW
- Type of construction IM V1  $\leq$  4.00 kW
- Type of construction IM V15  $\geq$  5.50 kW
- Enclosure IP55
- Duty type: continuous duty S1
- Thermal class F with temperature sensor, 1 PTC thermistor (size 80/90) / 3 PTC thermistors (from size 100)

#### Explosion-proof design:

- KSB surface-cooled IEC three-phase current squirrel-cage motor
- Efficiency class IE2 / IE3 to IEC 60034-30
- Rated voltage (50 Hz) 230 V / 400 V  $\leq$  2.50 kW
- Rated voltage (50 Hz) 400 V / 690 V  $\geq$  3.30 kW

- Rated voltage (60 Hz) - / 460 V  $\leq$  2.50 kW
- Rated voltage (60 Hz) 460 V / -  $\geq$  3.30 kW
- Type of construction IM V1  $\leq$  4.00 kW
- Type of construction IM V15  $\geq$  5.50 kW
- Enclosure IP55
- Duty type: continuous duty S1
- II 3G Ex ec IIC T3 Gc
- II 2G Ex eb IIC T3 Gb
- II 2G Ex db (eb) IIB T4 Gb
- II 2G Ex db (eb) IIC T4 Gb

### Drive (variable speed version)

#### KSB SuPremE motor:

- Surface-cooled KSB SuPremE motor, IEC-compatible, magnetless synchronous reluctance motor<sup>3)</sup> (PumpDrive 2 / PumpDrive 2 Eco / PumpDrive R required)
- Efficiency class IE4 / IE5 to IEC TS 60034-30-2:2016
- Mounting points to EN 50347:2001
- Envelope dimensions to DIN VDE 42673-4:2011-07
- Type of construction IM V1  $\leq$  4.00 kW
- Type of construction IM V15  $\geq$  5.50 kW
- Enclosure IP55
- Duty type: continuous duty S1
- Thermal class F with temperature sensor, 3 PTC thermistors
- Shaft centreline height 71 to 225 mm
- Rated power 0.55 kW to 45 kW
- Rated speed 1500 rpm or 3000 rpm
- Frequency 50 Hz / 60 Hz (PumpDrive input)
- Voltage 380 V to 480 V (PumpDrive input)

#### KSB SuPremE C1/D1:

- With terminal box for connecting to PumpDrive 2 or PumpDrive R for mounting on walls and in control cabinets

#### KSB SuPremE C2/D2:

- Equipped for being fitted with a motor-mounted PumpDrive 2

#### PumpDrive 2 / PumpDrive 2 Eco:

- Self-cooling frequency inverter of modular design for the continuously variable speed control of asynchronous motors and synchronous reluctance motors by means of analog standard signals, a field bus or the control panel
- Identical design of frequency inverter for motor mounting, wall mounting and cabinet mounting
- Mains voltage 3~ 380 V AC -10 % to 480 V AC +10 %
- Mains frequency 50 Hz to 60 Hz  $\pm$  2 %

#### PumpDrive R:

- Self-cooling frequency inverter of modular design for the continuously variable speed control of asynchronous motors and synchronous reluctance motors, such as KSB SuPremE motors or permanent magnet synchronous motors, by means of analog standard signals, a field bus or the control panel
- Identical design of frequency inverter for the mounting types wall mounting and cabinet mounting
- Mains voltage 3~ 380 V AC -10 % to 480 V AC +10 %

<sup>3)</sup> Motor sizes 0.55 kW / 0.75 kW with 1500 rpm are designed with permanent magnets.

- Extended mains voltage range (on request)
- Mains frequency 50 Hz to 60 Hz  $\pm$  2 %
- Extended power range with a nominal power of 110 kW (standard) or 1400 kW (on request)

**PumpMeter:**

- Intelligent pressure transmitter for pumps, with on-site display of measured values and operating data
- For recording the load profile of the pump
- Supplied completely assembled and parameterised for the individual pump

**KSB Guard**

- System for monitoring the pump's condition by means of temperature and vibration sensors
- Measured values and operating data may be retrieved via the KSB Guard app and the web portal at any time.

**Shaft seal**

- Single mechanical seal to EN 12756
- The shaft is fitted with a replaceable shaft sleeve in the shaft seal area (sizes 080-065-250, 100-080-200, 100-080-250)

**Impeller type**

- Closed radial impeller with multiply curved vanes
- Vortex impeller

## Designation

Table 3: Designation example

Position																																												
1	2	3	4	5	6	7	8	9	10	11	12	13	14	15	16	17	18	19	20	21	22	23	24	25	26	27	28	29	30	31	32	33	34	35	36	37	38	39	40	41	42	43	44	
E	T	C	B	0	5	0	-	0	2	5	-	1	2	5		C	C	S	A	A	0	7	D	1	0	1	0	0	2	e	x	B		P	D	2		M	K	S	B	I	E	4
See name plate and data sheet																																	See data sheet											

Table 4: Designation key

Position	Code	Description
1-4	Pump type	
	ETCB	Etachrom B
	ETCF	Etachrom B bottle rinser variant
5-16	Size, e.g.	
	050	Nominal suction nozzle diameter [mm]
	025	Nominal discharge nozzle diameter [mm]
	125	Nominal impeller diameter [mm]
16	F	Etachrom B with vortex impeller (size 065-050-125 only)
17	Pump casing material	
	C	Stainless steel 1.4571
18	Impeller material	
	C	Stainless steel 1.4571/1.4408
19	Design	
	E	Materials in contact with food to Regulation (EC) 1935/2005
	F	Bottle rinser variant
	H	Approved for drinking water to ACS
	K	Approved for drinking water to KSB standard
	U	Approved for drinking water to UBA
	S	Standard
	W	Approved for drinking water to WRAS
X	Non-standard (BT3D, BT3)	
20-21	Casing cover	
	AA	Internal circulation (seal chamber only)
	AS	Internal circulation (seal chamber only), casing cover with anti-swirl baffles
	AV	Vented seal chamber
	EA	External circulation
	ES	External circulation, casing cover with anti-swirl baffles
	FS	External flushing, casing cover with anti-swirl baffles
22-23	Seal code, single mechanical seal	
	01	Q1Q1VGG 1A (ZN1181)
	07	Q1Q1EGG 1A (ZN1181)
	09	U3U3VGG MG13G60
	10	Q1Q1X4GG 1 (ZN1181)
	11	BQ1EGG-WA (WA = drinking water) 1 (ZN1181)
	12	Q12Q1M1GG1 M37GN83
	17	Q1BVGG M7N
	26	XYHY2VY Roten Uniten 3
	45	BQ7E1GG/Y10 KU 022 S0 - eMG12G6
	46	Q7Q7E1GG/Y10 KU 022 S0 - eMG12G6
	66	Q7Q7EGG/Y10-WA eMG13G6
	67	Q6Q6X4GG MG13G60
	68	BQ7V16GG/Y10 KU 022 S0 - eMG12G6
69	Q7Q7V16GG/Y10 KU 022 S0 - eMG12G6	
24	Scope of supply	
	A	Pump, without motor (figure 0 bare-shaft pump)
	D	Pump, motor
25	Shaft unit	
	1	Shaft unit 25.1
	2	Shaft unit 25.2



Position	Code	Description
25	3	Shaft unit 35
26-29	Motor rating P <sub>N</sub> [kW]	
	0750	7,50
	...	...
	0300	30,00
30	Number of motor poles	
31-32	Explosion protection	
	ex	With explosion-proof motor
	--	Without explosion-proof motor
33	Product generation	
	B	Etachrom B 2015
34-37	PumpDrive	
	PD2	PumpDrive 2
	PD2E	PumpDrive 2 Eco
38	PumpMeter	
	M	PumpMeter
39-41	Motor manufacturer	
	KSB	KSB
	SIE	Siemens
	LOH	Loher
	HAL	Halter
42-44	Efficiency class	

## Materials

Table 5: Overview of available materials

Part No.	Description	Material	Fluid temperature [°C]	
			T <sub>min</sub>	T <sub>max</sub>
101	Pump casing	CrNiMo steel 1.4571	-30	+110
132.01	Intermediate piece	Grey cast iron EN-GJL-250 / cataphoresis	-30	+110
163	Discharge cover	CrNiMo steel 1.4571	-30	+110
183	Foot	S235 JR	-30	+110
210	Shaft	CrNiMo steel 1.4571	-30	+110
230	Impeller	CrNiMo steel 1.4571	-30	+110
		CrNiMo steel 1.4408	-30	+110
341	Drive lantern	Grey cast iron EN-GJL-250 / cataphoresis	-30	+110
412.35	O-ring	EPDM 70	-30	+110
		HNBR 75	-30	+110
		FKM80	-30	+110
502.01	Casing wear ring	CrNiMo steel 1.4571	-30	+110
502.02	Casing wear ring	CrNiMo steel 1.4571	-30	+110
523	Shaft sleeve	CrNiMo steel 1.4571	-30	+110
901.99	Hexagon head bolt	Steel 8.8 A2A	-30	+110
903.01	Screw plug	CrNiMo steel A4	-30	+110
920.01	Nut	CrNiMo steel A4	-30	+110

 The pumps are free from substances impairing the adhesive strength of the paint, such as silicone.

### Coating and preservation

- Coating and preservation to KSB standard AN 1897/54-09
- Pump casing without coating
- Drive lantern, intermediate piece with cathoretic coating

Table 6: Primer

Type	Primer
A1	<ul style="list-style-type: none"> <li>Hydro-dip primer for steel and cast components</li> <li>Spray-coating with compressed air possible</li> <li>Water-thinned hydro dip primer with good anti-corrosive properties</li> <li>Dry film thickness: 40-50 µm</li> </ul>

Table 7: Top coat

Type	Top coat <sup>4)</sup>
A1	<ul style="list-style-type: none"> <li>Quick drying, water-thinned paint (acrylate alkyd combination) with anti-corrosive properties and lead-free pigmentation</li> <li>T up to 140 °C</li> <li>Dry film thickness: 60 µm</li> </ul>

### Product benefits

- Maintenance-free mechanical seal ensures operating reliability
- Easy to dismantle due to back pull-out design; no need to remove the pump casing from the piping
- Optimised hydraulic components for high efficiency help reduce energy consumption
- Corrosion-resistant: wetted components made of stainless steel (1.4571)
- Long service life, maintenance-free with high-quality standardised mechanical seal to EN 12756

### Product information

#### Product information as per Regulation No. 1907/2006 (REACH)

For information as per European chemicals regulation (EC) No. 1907/2006 (REACH) see <https://www.ksb.com/en-global/company/corporate-responsibility/reach>.

#### Product information as per Regulation No. 547/2012 (for water pumps with a maximum shaft power of 150 kW) implementing "Ecodesign" Directive 2009/125/EC

- Minimum efficiency index: see data sheet
- The benchmark for the most efficient water pumps is MEI  $\geq 0.70$ .
- Year of construction: see data sheet
- Manufacturer's name or trade mark, commercial registration number and place of manufacture: see data sheet or order documentation
- Product's type and size identifier: see data sheet
- Hydraulic pump efficiency (%) with trimmed impeller: see data sheet
- Pump performance curves, including efficiency characteristics: see documented characteristic curve

- The efficiency of a pump with a trimmed impeller is usually lower than that of a pump with the full impeller diameter. Trimming of the impeller will adapt the pump to a fixed duty point, leading to reduced energy consumption. The minimum efficiency index (MEI) is based on the full impeller diameter.
- Operation of this water pump with variable duty points may be more efficient and economic when controlled, for example, by the use of a variable speed drive that matches the pump duty to the system.
- Information relevant for disassembly, recycling or disposal at end of life: see installation/operating manual
- Information on benchmark efficiency or benchmark efficiency graph for MEI = 0.70 (0.40) for the pump based on the model shown in the Figure are available at: <http://www.europump.org/efficiencycharts>

### Certifications

Table 8: Overview

Label	Effective in:	Comment
	All countries	Certified quality management to ISO 9001
	France	Approved in accordance with the French drinking water regulation

### Acceptance tests and warranty

- Materials inspection and testing**
  - Test report 2.2 on request
- Final inspection**
  - Inspection certificate 3.1 to EN 10204 on request
- Hydraulic test**
  - The duty point of each pump with a delivery address or final destination in Europe is guaranteed to ISO 9906/2A.
  - The duty point of each pump with a delivery address or final destination outside of Europe is guaranteed to ISO 9906/3.
- The following **acceptance tests** can be performed and certified at **extra charge**:
  - Performance test to ISO 9006
  - NPSH test
- Other inspections/tests on request
- Warranty**  
Warranties are given within the scope of the valid terms and conditions of sale and delivery.

<sup>4</sup> The top coats are suitable for indoor and outdoor installation in slightly aggressive atmospheres.

Overview of product features / selection tables

Overview of fluids handled

Table 9: Symbols key

Symbol	Description
X	Standard
-	Version not available / not feasible

The table of fluids handled is a selection aid for different applications. It serves as guidance and is based on long-standing experience. The data are reference values and are not to be considered generally binding recommendations. They shall not be the basis for warranty claims. Please contact your nearest sales branch for in-depth advice.

**Example:** Pure water 15 °C, Q = 40 m<sup>3</sup>/h, H = 51 m  
**Selection:** Etachrom B 065-040-200 CC A11D2  
 065-040-200 Size (as per characteristic curve 2900 rpm)  
 11 Variant code (according to selection table)  
 Motor rating required: 11 kW

Table 10: Selection table

Fluids handled	Fluid	Variant	Application limits		Shaft seal (mechanical seal)													
			Percentage	Temperature	Q1Q1VGG	Q1Q1EGG	U3U3VGG	Q1Q1X4GG	BQ1EGG-WA <sup>5)</sup>	Q12Q1M1GG1	Q1BVGG	BQ7E1GG/Y10 <sup>6)</sup>	Q7Q7E1GG/Y10 <sup>6)</sup>	Q7Q7EGG/Y10-WA	Q6Q6X4GG	BQ7V16GG/Y10 <sup>6)</sup>	Q7Q7V16GG/Y10 <sup>6)</sup>	
					Design code													
			[%]	[°C]	01	07	09	10	11	12	17	45	46	66	67	68	69	
Alkaline cleaning agents	10120	50120	-	-	-	X	-	X	-	X	-	-	-	-	-	-	-	
Alkaline degreasing solution	10120	51134	≤ 10 NaOH	80	-	X	-	-	-	-	-	-	-	-	-	-	-	
Alcohol (ethanol)	10171	50171	-	-	-	-	-	-	X	-	-	X	X	-	-	-	-	
Ammonia water (ammonia solution)	10113	50113	-	-	-	-	-	-	-	-	-	-	-	-	-	-	-	
Ammonium bicarbonate	10116	50116	≤ 10	≤ 40	-	-	-	-	X	-	-	-	-	-	-	-	-	
Cider	10327	50338	-	-	-	-	-	-	X	-	-	X	X	-	-	-	-	
Ethanol (alcohol)	10171	50171	-	-	-	-	-	-	X	-	-	X	X	-	-	-	-	
Ethylene glycol <sup>7)</sup>	10205	50207	-	-	-	X	-	-	X	-	-	-	-	X	-	-	-	
Petrol	10301	50301	-	-	-	-	-	-	-	-	X	-	-	-	-	-	-	
Beer mash	10328	50328	-	-	-	-	-	-	-	X	-	-	-	-	-	-	-	
Beer wort	10329	50329	-	-	-	-	-	-	-	X	-	-	-	-	-	-	-	
Spirits	10327	50330	-	-	-	-	-	-	X	-	-	X	X	-	-	-	-	
Butanol	10170	50170	-	-	-	-	-	-	X	-	-	-	-	-	-	-	-	
Butanoic acid	10436	50436	100	≤ 30	-	-	-	-	X	X	-	-	-	-	-	-	-	
Calcium acetate	10386	50386	10	-	-	-	-	-	X	-	-	-	-	-	-	-	-	
Calcium nitrate	10389	50389	≤ 10	≤ 30	-	-	-	X	-	-	-	-	-	-	-	-	-	
Cleaning in place (CIP) without further specifications	10861	50861	-	-	-	X	-	-	-	X	-	-	-	-	-	-	-	
Deionised water (fully desalinated) <sup>8)</sup>	10669	50669	-	≤ 110	-	-	-	-	X	-	-	-	-	-	X	-	-	
Distilled water	10669	50669	-	≤ 60	-	-	-	-	X	-	-	-	-	-	-	-	-	
Diesel oil	10304	50304	-	-	-	-	-	X	-	-	X	-	-	-	-	-	-	
Decarbonised water <sup>9)</sup>	10669	50673	-	≤ 60	-	-	-	-	X	-	-	-	-	-	-	-	-	
Peanut oil	10350	50364	-	≤ 90	-	-	-	X	-	-	X	-	-	-	-	-	X	
Vinegar (= 5 % acetic acid)	10439	50439	≤ 5	-	-	-	-	-	X	-	-	-	-	-	-	-	-	
Ethanol	10171	51987	-	-	-	-	-	-	X	-	-	X	X	-	-	-	-	

<sup>5)</sup> Combinations of soft/hard seal face materials (BQ1) can only be used for fluids up to a total solids content of 50 mg/l. Higher total solids contents will result in leakage and a shorter service life.  
<sup>6)</sup> FDA-approved  
<sup>7)</sup> Antifreeze agent on ethylene glycol basis with inhibitors. Content: > 20 % to 50 % (e.g. Antifrogen N)  
<sup>8)</sup> Conductivity at 25 °C: < 250 µS/cm, SiO<sub>2</sub> silicate content ≤ 10 mg/l  
<sup>9)</sup> Chloride content ≤ 300 mg/l; if the value is exceeded, water analysis is required.

Fluids handled	Fluid	Variant	Application limits		Shaft seal (mechanical seal)													
			Percentage	Temperature	Q1Q1VGG	Q1Q1EGG	U3U3VGG	Q1Q1X4GG	BQ1EGG-WA <sup>5)</sup>	Q1Q1M1GG1	Q1BVGG	BQ7E1GG/Y10 <sup>6)</sup>	Q7Q7E1GG/Y10 <sup>6)</sup>	Q7Q7EGG/Y10-WA	Q6Q6X4GG	BQ7V16GG/Y10 <sup>6)</sup>	Q7Q7V16GG/Y10 <sup>6)</sup>	
					Design code													
			[%]	[°C]	01	07	09	10	11	12	17	45	46	66	67	68	69	
Condenser water (sugar production)	10332	50332	-	-	-	-	-	-	-	-	X	X	-	-	-	-		
Fire-fighting water <sup>9)</sup>	10199	50204	-	≤ 25 <sup>10)</sup>	-	-	X	-	-	X	-	-	-	-	-	-		
Lye for bottle rinsers	10111	Var. <sup>11)</sup>	≤ 10	≤ 80	-	X	-	-	-	X	-	-	-	-	-	-		
Antifreeze agent (ethylene glycol) <sup>7)</sup>	10214	Var. <sup>11)</sup>	See <sup>7)</sup>	≤ 110	-	X	-	-	X	-	-	-	-	X	-	-		
Ethylene glycol base anti-freeze, inhibited	10270	Var. <sup>11)</sup>	See <sup>7)</sup>	≤ 110	-	X	-	-	X	-	-	-	-	X	-	-		
Antifreeze agent (propylene glycol) <sup>7)</sup>	10962	Var. <sup>11)</sup>	See <sup>7)</sup>	≤ 110	-	X	-	-	X	-	-	-	-	X	-	-		
Propylene glycol base anti-freeze, inhibited	10963	Var. <sup>11)</sup>	See <sup>7)</sup>	≤ 110	-	X	-	-	X	-	-	-	-	X	-	-		
Tannic acid	10445	Var. <sup>11)</sup>	≤ 50	-	-	-	-	-	-	X	-	-	-	-	-	-		
Beverages containing carbon dioxide	10846	50846	≤ 00	-	-	-	-	-	-	-	X	X	-	-	-	-		
Glycerine	10311	Var. <sup>11)</sup>	≤ 90	-	-	-	-	-	-	X	-	-	-	-	-	-		
Fuel oil, light	10308	50308	-	≤ 60	-	-	-	X	-	X	-	-	-	-	-	-		
Heating water <sup>12)</sup>	10499	50499	-	≤ 110	-	-	-	X	X	-	-	-	-	-	-	-		
Hydraulic oil	10346	50351	-	-	-	-	-	X	-	X	-	-	-	-	-	-		
Potassium hydroxide	10121	Var. <sup>11)</sup>	≤ 10	≤ 80	-	X	-	X	-	-	-	-	-	-	-	-		
Potassium carbonate	10123	50122	≤ 10	≤ 80	-	X	-	-	X	-	-	-	-	-	-	-		
Aluminium potassium sulphate	10381	50381	≤ 3	≤ 20	X	-	-	-	-	-	-	-	-	-	-	-		
Potassium sulphate	10401	50402	≤ 3	-	-	-	-	-	-	X	-	-	-	-	-	-		
Kerosene (jet fuel)	10317	51168	-	≤ 60	-	-	-	X	-	X	-	-	-	-	-	-		
Condensate <sup>8)</sup>	10495	50660	-	≤ 110	-	-	-	-	X	-	-	-	-	-	-	-		
Cooling water (without antifreeze)	10668	Var. <sup>11)</sup>	-	≤ 90 <sup>10)</sup>	-	-	-	X	-	-	-	-	-	-	-	-		
Cooling water pH ≥ 7.5 (with antifreeze) <sup>7)</sup>	10214	Var. <sup>11)</sup>	-	≤ 110	-	X	-	-	X	-	-	-	-	X	-	-		
Cooling lubricant (Cimcool)	10188	50188	-	≤ 60	-	-	X	-	-	-	-	-	-	-	-	-		
Copper sulphate	10407	50407	≤ 5	RT <sup>13)</sup>	-	-	-	-	X	-	-	-	-	-	-	-		
Slightly contaminated water <sup>9)</sup>	10484	50696	-	≤ 60 <sup>10)</sup>	-	-	-	X	-	-	-	-	-	-	-	-		
Linseed oil	10350	50368	-	≤ 90	-	-	-	X	-	-	X	-	-	-	-	X		
Corn oil	10350	50369	-	≤ 90	-	-	-	X	-	-	X	-	-	-	-	X		
Maleic acid	10445	51684	≤ 10	-	-	-	-	-	-	X	-	-	-	-	-	-		
Methyl alcohol (methanol)	10174	50174	-	-	-	-	-	-	X	-	-	-	-	-	-	-		
Lactic acid	10449	Var. <sup>11)</sup>	≤ 50	-	-	-	-	-	-	X	-	-	-	-	-	-		
Mineral oil	10346	50352	-	-	-	-	-	X	-	X	-	-	-	-	-	-		
Sodium hydrogen carbonate	10151	50151	≤ 6	≤ 20	-	-	-	X	-	-	-	-	-	-	-	-		
Sodium hydroxide (caustic soda)	10111	51673	≤ 10	≤ 80	X	-	-	-	-	X	-	-	-	-	-	-		
Sodium carbonate	10146	50146	≤ 6	≤ 60	-	-	-	-	X	-	-	-	-	-	-	-		
Sodium nitrate	10423	50423	≤ 10	≤ 90	-	-	-	-	X	-	-	-	-	-	-	-		
Sodium sulphate	10395	50395	≤ 5	≤ 60	-	-	-	-	X	-	-	-	-	-	-	-		
Caustic soda (sodium hydroxide)	10158	50158	≤ 20	≤ 60	-	-	-	-	X	-	-	-	-	-	-	-		
Paraffin	10319	51687	-	-	-	-	-	-	-	X	-	-	-	-	-	-		
Kerosene	10310	50310	-	-	-	-	-	X	-	-	X	-	-	-	-	-		
Vegetable oil, pure	10350	Var. <sup>11)</sup>	-	≤ 90	-	-	-	X	-	-	X	-	-	-	-	X		

<sup>10</sup> Mechanical seal suitable for t ≤ 110 °C  
<sup>11</sup> Var. = various  
<sup>12</sup> Conductivity at 25 °C: 100 to 800 µS/cm  
<sup>13</sup> RT = room temperature

Fluids handled	Fluid	Variant	Application limits		Shaft seal (mechanical seal)													
			Percentage	Temperature	Q1Q1VGG	Q1Q1EGG	U3U3VGG	Q1Q1X4GG	BQ1EGG-WA <sup>5)</sup>	Q12Q1M1GG1	Q1BVGG	BQ7E1GG/Y10 <sup>6)</sup>	Q7Q7E1GG/Y10 <sup>6)</sup>	Q7Q7EGG/Y10-WA	Q6Q6X4GG	BQ7V16GG/Y10 <sup>6)</sup>	Q7Q7V16GG/Y10 <sup>6)</sup>	
					Design code													
			[%]	[°C]	01	07	09	10	11	12	17	45	46	66	67	68	69	
Phosphoric acid	10452	50947	≤ 5	≤ 40	X	-	-	-	-	-	X	-	-	-	-	-		
Phosphoric acid	10452	50452	≤ 10	≤ 40	X	-	-	-	-	-	X	-	-	-	-	-		
Propanol (propyl alcohol)	10170	51096	-	-	-	-	-	X	-	-	-	-	-	-	-	-		
Rapeseed oil	10350	50370	-	≤ 90	-	-	-	X	-	-	X	-	-	-	-	X	X	
Raw water <sup>9)</sup>	10658	50658	-	≤ 60 <sup>10)</sup>	-	-	-	X	-	-	-	-	-	-	-	-		
Lubricating oil	10347	Var. <sup>11)</sup>	-	-	-	-	-	X	-	-	X	-	-	-	-	-		
Cutting oil	10346	50356	-	-	-	-	-	X	-	-	X	-	-	-	-	-		
Sulphuric acid	10455	50455	≤ 5	20	X	-	-	-	-	-	-	-	-	-	-	-		
Sulphuric acid	10455	50456	≤ 2,5	≤ 50	X	-	-	-	-	-	-	-	-	-	-	-		
Sulphurous acid	10456	51129	≤ 10	25	X	-	-	-	-	-	-	-	-	-	-	-		
Swimming pool water (fresh water)	10655	50725	-	≤ 60	-	-	-	X	-	-	-	-	-	-	-	-		
Silicone oil	10346	50357	-	-	-	-	-	X	-	-	X	-	-	-	-	-		
Soy-bean oil	10350	50371	-	≤ 90	-	-	-	X	-	-	X	-	-	-	-	X	X	
Edible oil	10350	Var. <sup>11)</sup>	-	≤ 90	-	-	-	X	-	-	X	-	-	-	-	-		
Surface water	10683	Var. <sup>11)</sup>	-	≤ 60 <sup>10)</sup>	-	-	-	X	-	-	-	-	-	-	-	-		
Partly desalinated water	10669	50736	-	≤ 110	-	-	-	-	X	-	-	-	-	-	-	-		
Drinking water <sup>9)</sup>	10665	Var. <sup>11)</sup>	-	≤ 60 <sup>10)</sup>	-	-	-	-	X	-	-	-	-	-	-	-		
Turbine oil (does not apply to SFD oils)	10347	50347	-	≤ 80	-	-	-	X	-	-	X	-	-	-	-	-		
Water / bathing water (fresh water) <sup>9)</sup>	10665	50725	-	≤ 60	-	-	-	-	X	-	-	-	-	-	-	-		
Water, desalinated <sup>14)</sup>	10669	50837	-	-	-	-	-	-	X	-	-	-	-	-	X	-		
Water/oil emulsion	10192	51166	95%/5%	≤ 60	-	-	X	-	-	-	X	-	-	-	-	-		
Tartaric acid	10460	50460	≤ 50	-	-	-	-	-	-	-	X	-	-	-	-	-		
Citric acid	10438	50438	≤ 50	RT <sup>13)</sup>	-	-	-	-	X	-	X	-	-	-	-	-		
Sugar juice (sugar production)	19005	50333	20	≤ 100	-	-	-	-	-	X	X	-	-	-	-	-		

<sup>14</sup> Conductivity > 2 µS/cm < 10 µS/cm, SiO<sub>2</sub> < 10 mg/l, solids max. 5 mg/l

**Impellers**

- Closed radial impeller with multiply curved vanes
- Vortex impeller

**Table 11: Machining type, materials**

Closed radial impeller			Free-flow impeller
Stainless steel 1.4571		Stainless steel 1.4408	Stainless steel 1.4308
Projection-welded	Laser-welded	Cast	Cast
050-025-125	050-032-200	050-025-250	065-050-125
050-025-125.1	065-040-200	050-032-250	-
050-025-160	065-050-160	065-040-250	-
050-025-200	-	065-050-200	-
050-032-125	-	065-050-250	-
050-032-125.1	-	080-065-200	-
050-032-160	-	080-065-250	-
065-040-125	-	100-080-200	-
065-040-160	-	100-080-250	-
065-050-125	-	-	-

**Pressure limits and temperature limits**
**Table 12: Pressure limits and temperature limits**

Material variant	Fluid temperature	Operating pressure <sup>15)</sup>	Test pressure <sup>16)</sup>
	[°C]	[bar]	[bar]
C	-30 to +110	≤ 12	≤ 16

<sup>15</sup> The sum of inlet pressure and shut-off head must not exceed the value indicated.

<sup>16</sup> The casing components are checked for leakage by means of internal pressure tests to AN 1897/75-03D00 with water.

Technical data

Etachrom B

Size	Shaft unit	Impeller				Balancing hole	Discharge-side casing wear ring
		$\varnothing_{\min}$	$\varnothing_{\max}$	Outlet width	Free passage		
		[mm]	[mm]	[mm]	[mm]		
050-025-125.1	WS 25.1	110	136	6,0	5,0	-	-
050-025-125	WS 25.1	110	136	11,7	11,0	-	-
050-025-160	WS 25.1	135	166	9,8	9,0	-	-
050-025-200	WS 25.1	166	196	8,0	7,0	✓	✓
050-025-250	WS 25.2	212	260	8,0	7,5	✓	✓
050-032-125.1	WS 25.1	110	136	6,0	5,0	-	-
050-032-125	WS 25.1	110	136	11,7	11,0	-	-
050-032-160	WS 25.1	135	166	9,8	9,0	-	-
050-032-200	WS 25.1	166	196	8,0	7,0	✓	✓
050-032-250	WS 25.2	212	260	8,0	7,5	✓	✓
065-040-125	WS 25.1	110	136	16,8	11,5	-	-
065-040-160	WS 25.1	135	166	14,4	12,0	✓	✓
065-040-200	WS 25.1	166	196	12,0	11,0	✓	✓
065-040-250	WS 25.2	214	260	8,0	8,0	✓	✓
065-050-125	WS 25.1	110	142	20,0	15,0	-	-
065-050-160	WS 25.1	142	170	17,0	16,0	✓	✓
065-050-200	WS 25.2	170	220	11,5	11,0	✓	✓
065-050-250	WS 25.2	220	260	12,0	12,0	✓	✓
080-065-200	WS 25.2	180	219	17,0	16,0	✓	✓
080-065-250	WS 35	220	260	13,9	13,0	✓	✓
100-080-200	WS 35	180	219	23,5	20,0	✓	✓
100-080-250	WS 35	220	269	19,0	19,0	✓	✓

**Etachrom B, n = 2900 rpm / n = 3500 rpm**

Size	Motor	50 Hz	60 Hz	50 Hz [400 V] 60 Hz [460 V]
		[kW]	[kW]	[~A] <sup>17)</sup>
050-025-125.1/072	80M	0,75	-	1,8
050-025-125.1/112	80M	1,10	1,27	2,6
050-025-125.1/152	90S	1,50	1,75	3,4
050-025-125.1/222	90L	2,20	2,55	4,6
050-025-125.1/302	100L	3,00	3,45	6,3
050-025-125.1/402	112M	4,00	4,55	8,3
050-025-125/072	80M	0,75	-	1,8
050-025-125/112	80M	1,10	-	2,6
050-025-125/152	90S	1,50	1,75	3,4
050-025-125/222	90L	2,20	2,55	4,6
050-025-125/302	100L	3,00	3,45	6,3
050-025-125/402	112M	4,00	4,55	8,3
050-025-160/152	90S	1,50	-	3,4
050-025-160/222	90L	2,20	2,55	4,6
050-025-160/302	100L	3,00	3,45	6,3
050-025-160/402	112M	4,00	4,55	8,3
050-025-160/552	132S	-	6,30	11,0
050-025-160/752	132S	-	8,60	14,6
050-025-200/302	100L	3,00	-	6,3
050-025-200/402	112M	4,00	4,55	8,3
050-025-200/552	132S	5,50	6,30	11,0
050-025-200/752	132S	7,50	8,60	14,6
050-025-200/1102	160M	-	12,60	20,7
050-025-200/1502	160M	-	17,30	28,0
050-025-250/552	132S	5,50	-	11,0
050-025-250/752	132S	7,50	-	14,6
050-025-250/1102	160M	11,00	-	20,7
050-025-250/1502	160M	15,00	-	28,0
050-032-125.1/072	80M	0,75	-	1,8
050-032-125.1/112	80M	1,10	-	2,6
050-032-125.1/152	90S	1,50	1,75	3,4
050-032-125.1/222	90L	-	2,55	4,6
050-032-125.1/302	100L	-	3,45	6,3
050-032-125.1/402	112M	-	4,55	8,3
050-032-125/152	90S	1,50	-	3,4
050-032-125/222	90L	2,20	2,55	4,6
050-032-125/302	100L	3,00	3,45	6,3
050-032-125/402	112M	-	4,55	8,3
050-032-160/222	90L	2,20	-	4,6
050-032-160/302	100L	3,00	3,45	6,3
050-032-160/402	112M	4,00	4,55	8,3
050-032-160/552	132S	5,50	6,30	11,0
050-032-160/752	132S	-	8,60	14,6
050-032-160/1102	160M	-	12,60	20,7
050-032-200/302	100L	3,00	-	6,3
050-032-200/402	112M	4,00	-	8,3
050-032-200/552	132S	5,50	6,30	11,0
050-032-200/752	132S	7,50	8,60	14,6
050-032-200/1102	160M	11,00	12,60	20,7
050-032-200/1502	160M	-	17,30	28,0
050-032-250/552	132S	5,50	-	11,0
050-032-250/752	132S	7,50	-	14,6
050-032-250/1102	160M	11,00	-	20,7

<sup>17)</sup> The currents indicated are for orientation only. For exact currents refer to the motor name plate.



Size	Motor	50 Hz	60 Hz	50 Hz [400 V] 60 Hz [460 V]
		[kW]	[kW]	[~A] <sup>17)</sup>
050-032-250/1502	160M	15,00	-	28,0
050-032-250/1852	160L	18,50	-	33,0
065-040-125/152	90S	1,50	-	3,4
065-040-125/222	90L	2,20	2,55	4,6
065-040-125/302	100L	3,00	3,45	6,3
065-040-125/402	112M	4,00	4,55	8,3
065-040-160/302	100L	3,00	-	6,3
065-040-160/402	112M	4,00	-	8,3
065-040-160/552	132S	5,50	6,30	11,0
065-040-160/752	132S	7,50	8,60	14,6
065-040-160/1102	160M	11,00	12,60	20,7
065-040-160/1502	160M	-	17,30	28,0
065-040-200/552	132S	5,50	-	11,0
065-040-200/752	132S	7,50	-	14,6
065-040-200/1102	160M	11,00	12,60	20,7
065-040-200/1502	160M	-	17,30	28,0
065-040-200/1852	160L	-	21,30	33,0
065-040-250/752	132S	7,50	-	14,6
065-040-250/1102	160M	11,00	-	20,7
065-040-250/1502	160M	15,00	-	28,0
065-040-250/1802	160L	18,50	-	33,0
065-040-250/2202	180M	22,00	-	40,0
065-040-250/3002	200L	30,00	-	53,0
065-050-125/302	100L	3,00	-	6,3
065-050-125/402	112M	4,00	-	8,3
065-050-125/552	132S	5,50	6,30	11,0
065-050-125/752	132S	7,50	8,60	14,6
065-050-125/1102	160M	-	12,60	12,6
065-050-125/1502	160M	-	17,30	17,3
065-050-125F/222	90L	2,20	-	4,6
065-050-125F/302	100L	3,00	3,45	6,3
065-050-125F/402	112M	4,00	4,55	8,3
065-050-125F/552	132S	5,50	6,30	11,0
065-050-125F/752	132S	-	8,60	14,6
065-050-160/552	132S	5,50	-	11,0
065-050-160/752	132S	7,50	-	14,6
065-050-160/1102	160M	11,00	12,60	20,7
065-050-160/1502	160M	15,00	17,30	28,0
065-050-160/1852	160L	-	21,30	33,0
065-050-200/552	132S	5,50	-	11,0
065-050-200/752	132S	7,50	-	14,6
065-050-200/1102	160M	11,00	12,60	20,7
065-050-200/1502	160M	15,00	17,30	28,0
065-050-200/1852	160L	18,50	21,30	33,0
065-050-200/2202	180M	22,00	24,50	40,0
065-050-200/3002	200L	-	33,50	53,0
065-050-200/3702	200L	-	41,50	65,0
065-050-250/1502	160M	15,00	-	28,0
065-050-250/1852	160L	18,50	-	33,0
065-050-250/2202	180M	22,00	-	40,0
065-050-250/3002	200L	30,00	-	53,0
065-050-250/3702	200L	37,00	-	65,0
080-065-200/1102	160M	11,00	-	20,7
080-065-200/1502	160M	15,00	-	28,0
080-065-200/1852	160L	18,50	21,30	33,0
080-065-200/2202	180M	22,00	24,50	40,0
080-065-200/3002	200L	30,00	33,50	53,0

Size	Motor	50 Hz	60 Hz	50 Hz [400 V] 60 Hz [460 V]
		[kW]	[kW]	[~A] <sup>17)</sup>
080-065-200/3702	200L	37,00	41,50	65,0
080-065-250/1502	160M	15,00	-	33,0
080-065-250/1852	160L	18,50	-	28,0
080-065-250/2202	180M	22,00	-	40,0
080-065-250/3002	200L	30,00	-	53,0
080-065-250/3702	200L	37,00	-	65,0
080-065-250/4502	225M	45,00	-	78,0
100-080-200/1502	160M	15,00	-	28,0
100-080-200/1852	160L	18,50	-	33,0
100-080-200/2202	180M	22,00	-	40,0
100-080-200/3002	200L	30,00	-	53,0
100-080-200/3702	200L	37,00	-	65,0
100-080-200/4502	225M	45,00	-	78,0

**Etachrom B, n = 1450 rpm / n = 1750 rpm**

Size	Motor	50 Hz	60 Hz	50 Hz [400 V] 60 Hz [460 V]
		[kW]	[kW]	[~A] <sup>18)</sup>
050-025-125.1/054	80M	0,55	0,63	1,6
050-025-125/054	80M	0,55	0,63	1,6
050-025-160/054	80M	0,55	0,63	1,6
050-025-160/074	80M	-	0,86	2,0
050-025-160/114	90S	-	1,27	2,8
050-025-200/054	80M	0,55	-	1,6
050-025-200/074	80M	0,75	0,86	2,0
050-025-200/114	90S	1,10	1,27	2,8
050-025-200/154	90L	-	1,75	3,6
050-025-200/224	100L	-	2,55	5,1
050-025-250/074	80M	0,75	-	2,0
050-025-250/114	90S	1,10	1,27	2,8
050-025-250/154	90L	1,50	1,75	3,6
050-025-250/224	100L	-	2,55	5,1
050-025-250/304	100L	-	3,45	6,7
050-032-125.1/054	80M	0,55	0,63	1,6
050-032-125.1/074	80M	-	0,86	2,0
050-032-125/054	80M	0,55	0,63	1,6
050-032-125/074	80M	-	0,86	2,0
050-032-160/054	80M	0,55	0,63	1,6
050-032-160/074	80M	0,75	0,86	2,0
050-032-160/114	90S	-	1,27	2,8
050-032-160/154	90L	-	1,75	3,6
050-032-200/054	80M	0,55	-	1,6
050-032-200/074	80M	0,75	-	2,0
050-032-200/114	90S	1,10	1,27	2,8
050-032-200/154	90L	-	1,75	3,6
050-032-200/224	100L	-	2,55	5,1
050-032-250/074	80M	0,75	-	2,0
050-032-250/114	90S	1,10	-	2,8
050-032-250/154	90L	1,50	1,75	3,6
050-032-250/224	100L	2,20	2,55	5,1
050-032-250/304	100L	3,00	3,45	6,7
050-032-250/404	112M	-	4,55	8,8
050-032-250/554	132S	-	6,30	11,5
065-040-125/054	80M	0,55	0,63	1,6
065-040-125/074	80M	-	0,86	2,0
065-040-125/114	90S	-	1,27	2,8
065-040-160/054	80M	0,55	-	1,6
065-040-160/074	80M	0,75	-	2,0
065-040-160/114	90S	1,10	1,27	2,8
065-040-160/154	90L	1,50	1,75	3,6
065-040-160/224	100L	-	2,55	5,1
065-040-200/074	80M	0,75	-	2,0
065-040-200/114	90S	1,10	1,27	2,8
065-040-200/154	90L	1,50	1,75	3,6
065-040-200/224	100L	-	2,55	5,1
065-040-200/304	100L	-	3,45	6,7
065-040-250/114	90S	1,10	-	2,8
065-040-250/154	90L	1,50	1,75	3,6
065-040-250/224	100L	2,20	2,55	5,1
065-040-250/304	100L	3,00	3,45	6,7
065-040-250/404	112M	-	4,55	8,8

1213.5/30-EN

<sup>18)</sup> The currents indicated are for orientation only. For exact currents refer to the motor name plate.

Size	Motor	50 Hz	60 Hz	50 Hz [400 V] 60 Hz [460 V]
		[kW]	[kW]	[~A] <sup>18)</sup>
065-040-250/554	132S	-	6,30	11,5
065-050-125/054	80M	0,55	-	1,6
065-050-125/074	80M	0,75	0,86	2,0
065-050-125/114	90S	1,10	1,27	2,8
065-050-125/154	90L	-	1,75	3,6
065-050-125F/074	80M	0,75	0,86	2,0
065-050-125F/114	90S	-	1,27	2,8
065-050-160/074	80M	0,75	-	2,0
065-050-160/114	90S	1,10	1,27	2,8
065-050-160/154	90L	1,50	1,75	3,6
065-050-160/224	100L	2,20	2,55	5,1
065-050-160/304	100L	-	3,45	6,7
065-050-200/074	80M	0,75	-	2,0
065-050-200/114	90S	1,10	-	2,8
065-050-200/154	90L	1,50	1,75	3,6
065-050-200/224	100L	2,20	2,55	5,1
065-050-200/304	100L	3,00	3,45	6,7
065-050-200/404	112M	4,00	4,55	8,8
065-050-200/554	132S	-	6,30	11,5
065-050-250/154	90L	1,50	-	3,6
065-050-250/224	100L	2,20	2,55	5,1
065-050-250/304	100L	3,00	3,45	6,7
065-050-250/404	112M	4,00	4,55	8,8
065-050-250/554	132S	-	6,30	11,5
065-050-250/754	132M	-	8,60	15,5
065-050-250/1104	160M	-	12,60	21,0
080-065-200/154	90L	1,50	-	3,6
080-065-200/224	100L	2,20	2,55	5,1
080-065-200/304	100L	3,00	3,45	6,7
080-065-200/404	112M	4,00	4,55	11,5
080-065-200/554	132S	-	6,30	15,5
080-065-200/754	132M	-	8,60	8,8
080-065-250/224	100L	2,20	-	5,1
080-065-250/304	100L	3,00	-	6,7
080-065-250/404	112M	4,00	4,55	8,8
080-065-250/554	132S	5,50	6,30	11,5
080-065-250/754	132M	7,50	8,60	15,5
080-065-250/1104	160M	-	12,60	21,0
100-080-200/224	100L	2,20	-	5,1
100-080-200/304	100L	3,00	3,45	6,7
100-080-200/404	112M	4,00	4,55	8,8
100-080-200/554	132S	5,50	6,30	11,5
100-080-200/754	132M	7,50	8,60	15,5
100-080-200/1104	160M	-	12,60	21,0
100-080-250/304	100L	3,00	-	6,7
100-080-250/404	112M	4,00	-	8,8
100-080-250/554	132S	5,50	6,30	11,5
100-080-250/754	132M	7,50	8,60	15,5
100-080-250/1104	160M	11,00	12,60	21,0
100-080-250/1504	160L	15,00	17,30	28,5
100-080-250/1854	180M	-	21,30	35,0

Maximum permissible P/n value / maximum permissible speed

Size	Maximum permissible P/n value				Maximum permissible speed			
	Nominal impeller diameter [mm]				Nominal impeller diameter [mm]			
	125	160	200	250	125	160	200	250
050-025	0,006	0,006	0,006	0,0142	3600	3600	3600	3000
050-032	0,006	0,006	0,006	0,0142	3600	3600	3600	3000
065-040	0,006	0,006	0,006	0,0142	3600	3600	3600	3000
065-050	0,006	0,006	0,0142	0,0142	3600	3600	3600	3000
080-065	-	-	0,0142	0,0256	-	-	3600	3000
100-080	-	-	0,0256	0,0256	-	-	3000	1800

Axial mass moment of inertia

Size	Impeller diameter $Q_{min}$	Mass moment of inertia <sup>19)</sup> J
	[mm]	[kgm <sup>2</sup> ]
050-025-125.1	136	0,0015
050-025-125.1	123	0,0012
050-025-125.1	110	0,0010
050-025-125	136	0,0010
050-025-125	123	0,0010
050-025-125	110	0,0012
050-025-160	166	0,0031
050-025-160	151	0,0022
050-025-160	135	0,0015
050-025-200	196	0,0056
050-025-200	181	0,0045
050-025-200	166	0,0031
050-025-250	260	0,0421
050-025-250	229	0,0258
050-025-250	198	0,0171
050-032-125.1	136	0,0015
050-032-125.1	123	0,0012
050-032-125.1	110	0,0010
050-032-125	136	0,0010
050-032-125	123	0,0010
050-032-125	110	0,0012
050-032-160	166	0,0031
050-032-160	151	0,0022
050-032-160	135	0,0015
050-032-200	196	0,0056
050-032-200	181	0,0045
050-032-200	166	0,0031
050-032-250	260	0,0421
050-032-250	229	0,0258
050-032-250	198	0,0171
065-040-125	136	0,0020
065-040-125	123	0,0015
065-040-125	110	0,0012
065-040-160	166	0,0037
065-040-160	151	0,0027
065-040-160	135	0,0019
065-040-200	196	0,0080
065-040-200	181	0,0052
065-040-200	166	0,0037
065-040-250	260	0,0436
065-040-250	230	0,0264

1213.5/30-EN

<sup>19)</sup> With water fill

Size	Impeller diameter $Q_{min}$	Mass moment of inertia <sup>19)</sup> J
	[mm]	[kgm <sup>2</sup> ]
065-040-250	200	0,0155
065-050-125	142	0,0026
065-050-125	126	0,0018
065-050-125	110	0,0014
065-050-160	170	0,0052
065-050-160	156	0,0036
065-050-160	142	0,0026
065-050-200	220	0,0219
065-050-200	195	0,0147
065-050-200	170	0,0098
065-050-250	260	0,0456
065-050-250	235	0,0288
065-050-250	210	0,0197
080-065-200	219	0,0287
080-065-200	200	0,0215
080-065-200	180	0,0167
080-065-250	255	0,0515
080-065-250	233	0,0369
080-065-250	210	0,0282
100-080-200	219	0,0412
100-080-200	200	0,0329
100-080-200	180	0,0265
100-080-250	169	0,0802
100-080-250	240	0,0581
100-080-250	210	0,0429

**Liquid fill of pump**

Size	Fill
	[l]
050-025-125.1	1,2
050-025-125	1,2
050-025-160	1,6
050-025-200	1,7
050-025-250	3,8
050-032-125.1	1,2
050-032-125	1,2
050-032-160	1,6
050-032-200	1,7
050-032-250	3,8
065-040-125	1,3
065-040-160	2,0
065-040-200	2,3
065-040-250	4,0
065-050-125	2,3
065-050-160	2,4
065-050-200	3,3
065-050-250	4,0
080-065-200	4,3
080-065-250	4,9
100-080-200	6,5
100-080-250	6,5

Permissible forces and moments at the pump nozzles

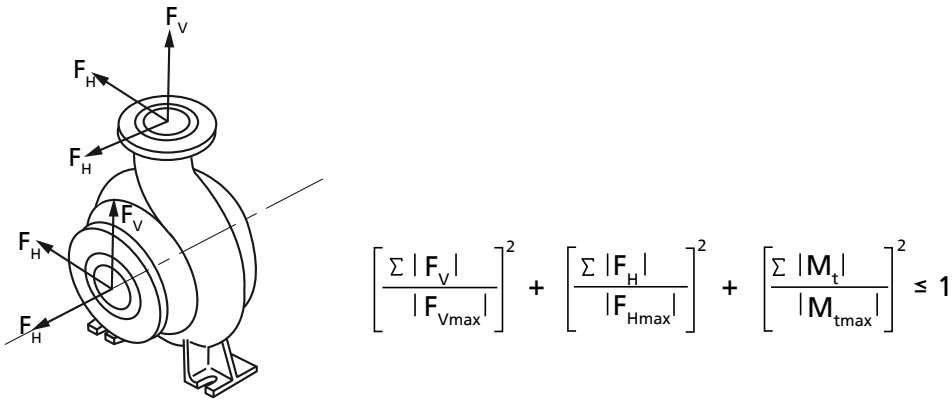

Fig. 1: Forces and moments at the pump nozzles

The following condition must be met:

$\sum |F_v|$ ,  $\sum |F_h|$ , and  $\sum |M_t|$  are the sums of the absolute values of the respective loads acting on the nozzles. Neither the load direction nor the load distribution among the nozzles are taken into account in these sums.

Table 13: Forces and moments at the pump nozzles<sup>20)</sup>

Size	$F_{Vmax}$	$F_{Hmax}$	$M_{tmx}$
	[kN]	[kN]	[kNm]
050-025-125.1	2,6	1,8	0,55
050-025-125	2,6	1,8	0,55
050-025-160	2,5	1,7	0,5
050-025-200	2,5	1,7	0,5
050-025-250	2,5	1,7	0,5
050-032-125.1	2,6	1,8	0,55
050-032-125	2,6	1,8	0,55
050-032-160	2,5	1,7	0,5
050-032-200	2,5	1,7	0,5
050-032-250	2,5	1,7	0,5
065-040-125	2,6	1,8	0,6
065-040-160	2,6	1,8	0,6
065-040-200	2,6	1,8	0,6
065-040-250	2,6	1,8	0,6
065-050-125	2,7	2,0	0,75
065-050-160	2,7	1,9	0,7
065-050-200	2,7	1,9	0,7
065-050-250	2,7	1,9	0,7
080-065-200	3,0	2,2	0,85
080-065-250	3,2	2,4	1,05
100-080-200	4,0	2,9	1,45
100-080-250	4,0	2,9	1,45

<sup>20)</sup> The indicated values apply to pumps made of chrome nickel molybdenum steel 1.4571 on non-grouted baseplates.

Noise characteristics

Table 14: Surface sound pressure level  $L_{pA}$  <sup>21) 22)</sup>

Rated power input $P_N$	Pump set	
	1450 rpm	2900 rpm
[kW]	[dB]	[dB]
0,55	55	64
0,75	57	64
1,1	60	64
1,5	60	69
2,2	64	69
3	64	71
4	62	73
5,5	68	72
7,5	68	72
11	69	75
15	69	75
18,5	70	75
22	-	78
30	-	79
37	-	79
45	-	79

<sup>21)</sup> Surface sound pressure level as per ISO 3744 and DIN EN ISO 20361 ; valid for a pump operating range of  $Q/Q_{BEP} = 0.8 - 1.1$  and non-cavitating operation. If noise levels are to be guaranteed: Add +3 dB for measuring and constructional tolerance.

<sup>22)</sup> Increase for 60 Hz operation: 3500 rpm +3 dB, 1750 rpm +1 dB



### Mechanical seal design

Installation dimensions to EN 12756

#### Example: KU022SO

Table 15: Designation

Code	Description
K	Design
	K Short design
U	Type
	U Unbalanced
022	Nominal diameter of the mechanical seal
S	Direction of rotation of the mechanical seal
	S Bi-directional
O	Anti-twist lock
	O Without lock

Table 16: Mechanical seal sizes

Size	Nominal impeller diameter [mm]			
	125	160	200	250
050-025	KU022SO	KU022SO	KU022SO	KU028SO
050-032	KU022SO	KU022SO	KU022SO	KU028SO
065-040	KU022SO	KU022SO	KU022SO	KU028SO
065-050	KU022SO	KU022SO	KU028SO	KU028SO
080-065	-	-	KU028SO	NU038SO
100-080	-	-	NU038SO	NU038SO

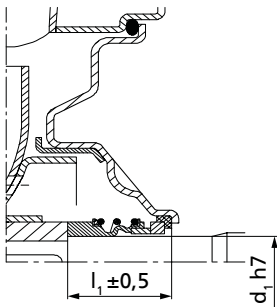

Fig. 2: Mechanical seal dimensions

Table 17: Mechanical seal dimensions

Code	d <sub>1</sub>	l <sub>1</sub>
	[mm]	[mm]
KU022SO	22	37,5
KU028SO	28	42,5
NU038SO	38	55,0

Table 18: Design code<sup>23)</sup>

Design code	Description				
	Primary ring	Mating ring	Secondary seal	Spring	Other parts
01	Q1	Q1	V	G	G
07	Q1	Q1	E	G	G
09	U3	U3	V	G	G
10	Q1	Q1	X4	G	G
11	B	Q1	E	G	G
12	Q12	Q1	M1	G	G
17	Q1	B	V	G	G
26	2	V	Y	X	X

Design code	Description				
	Primary ring	Mating ring	Secondary seal	Spring	Other parts
45	B	Q7	E1	G	G/Y10
46	Q7	Q7	E1	G	G/Y10
66	Q7	Q7	E	G	G/Y10
67	Q6	Q6	X4	G	G
68	B	Q7	V16	G	G/Y10
69	Q7	Q7	V16	G	G/Y10

Table 19: Material designation

Code	Material
2	Ceramics
B	Carbon, resin-impregnated
E	EPDM
E1	EPDM (to FDA, Regulation (EC) 1935/2004, Commission Regulation (EC) 2023/2006 - GMP)
G	CrNiMo steel
M1	FKM, double PTFE-coated
Q1	Silicon carbide
Q6	Silicon carbide with carbon
Q7	Silicon carbide, porous
Q12	Silicon carbide
U3	Tungsten carbide
V	Carbon (mating ring)
V	FKM (secondary seal)
V16	FKM (to FDA, Regulation (EC) 1935/2004, Commission Regulation (EC) 2023/2006 - GMP)
X	CrNiMo steel
X4	HNBR, e.g. Therban
Y	Viton

#### Additional information

- **Contact guard**
  - Cover plates on drive lantern to EN 294
- **Discharge cover with anti-swirl baffles**
  - For applications with a risk of wear by erosion.

<sup>23)</sup> Code to EN 12756

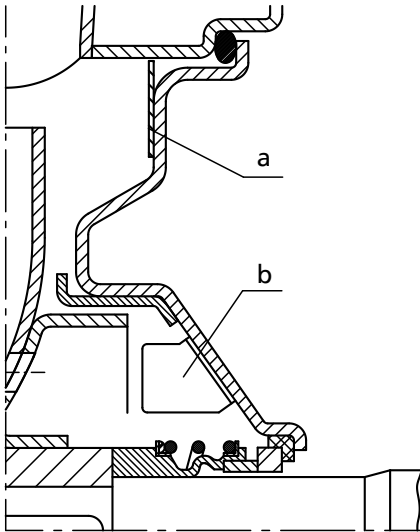
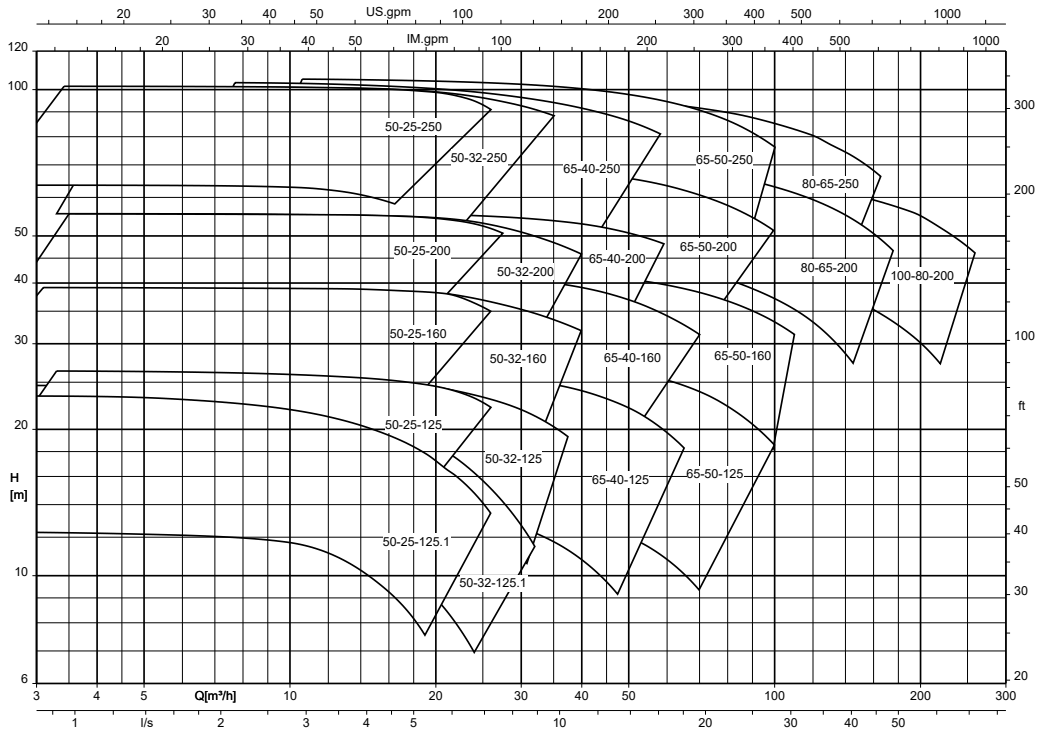

Fig. 3: Discharge cover with anti-swirl baffles

a	Ring
b	2 anti-swirl baffles at the circumference

Selection charts

Etachrom B, n = 2900 rpm



Etachrom B, n = 1450 rpm

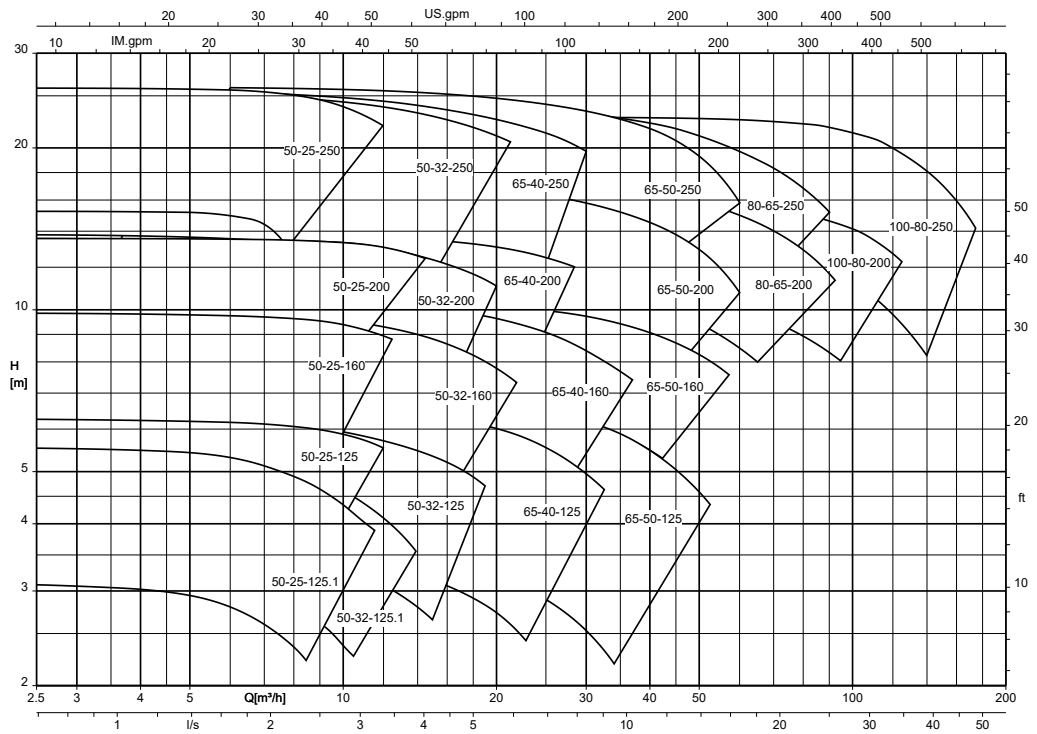

1213.5/30-EN

Etachrom B, n = 3500 rpm

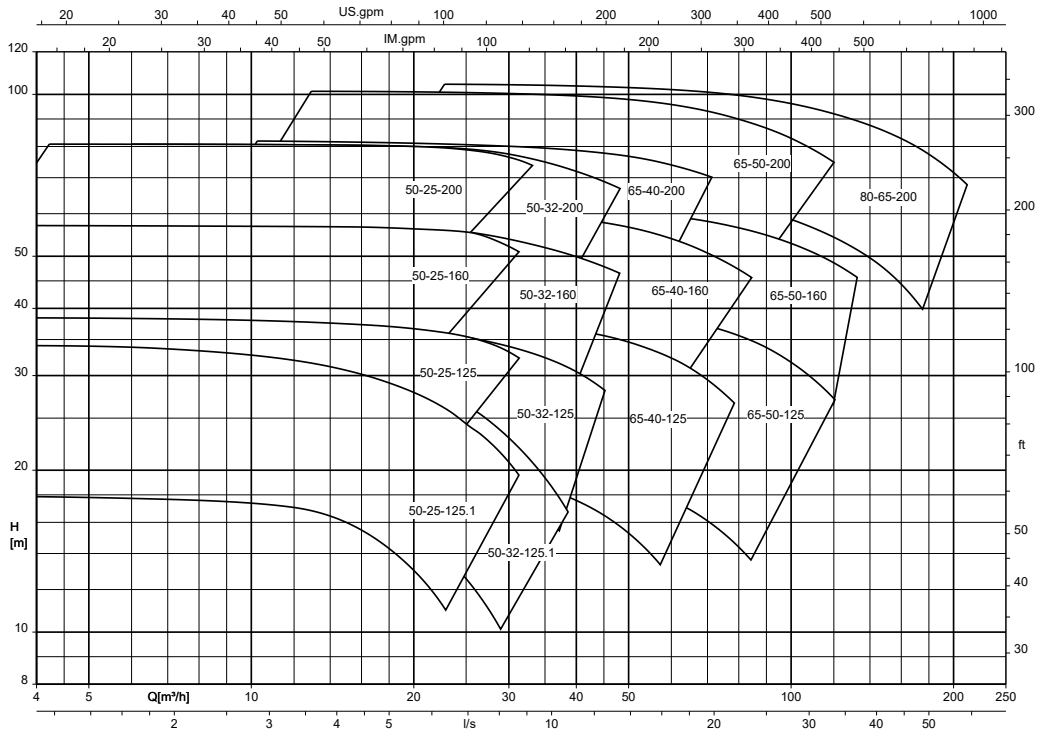

Etachrom B, n = 1750 rpm

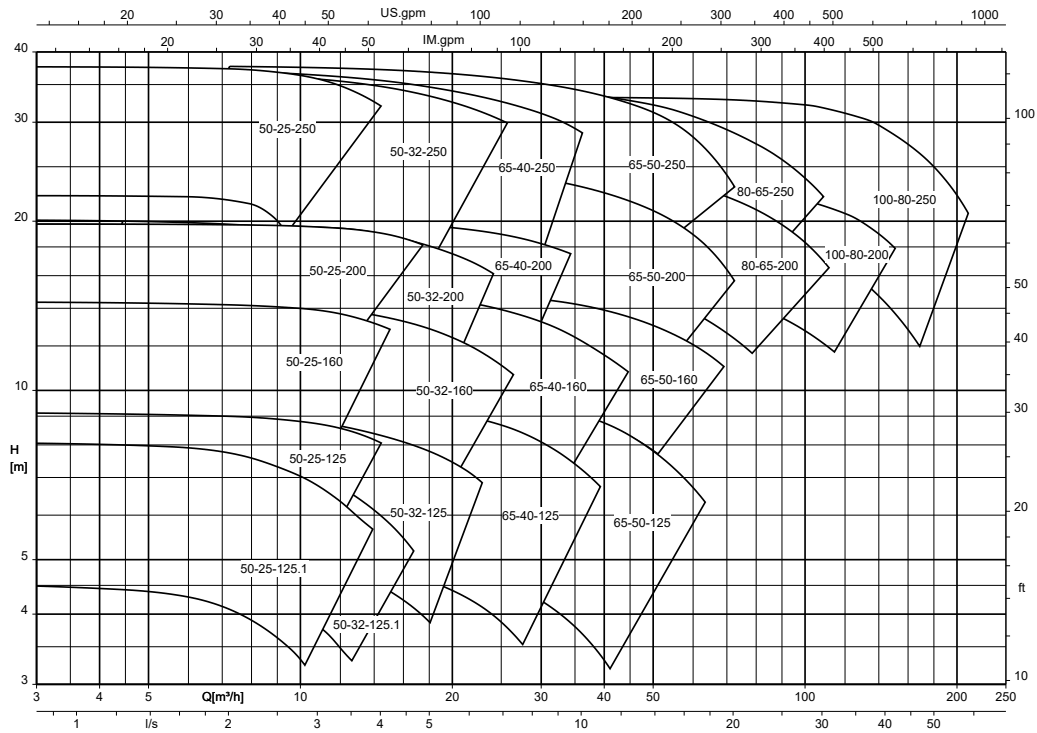

Dimensions and weights

Etachrom B 25, up to motor 112 (4.00 kW), with pump foot

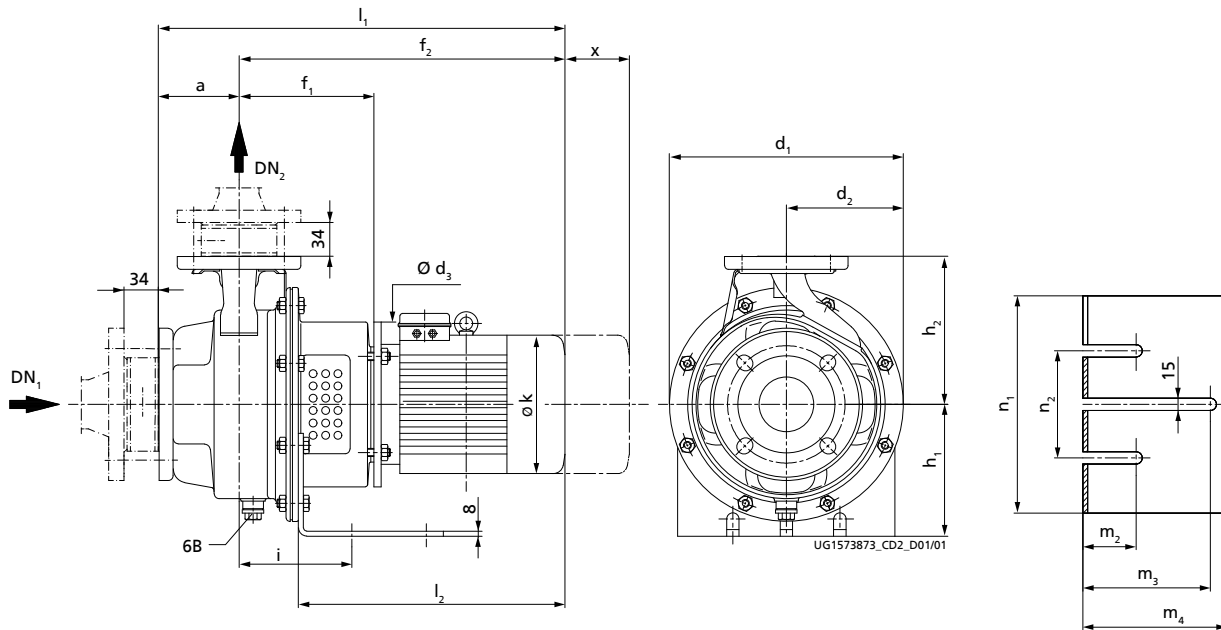

Fig. 4: Etachrom B with pump foot, dimensions [mm]

6B	Fluid drain	G <sup>3</sup> / <sub>8</sub> = ISO 228/1
----	-------------	---

DN = EN 1092-1/DN.../PN 16/B

Table 20: Dimensions

Size	1450 rpm	1750 rpm	2900 rpm	3500 rpm	a	d <sub>1</sub>	d <sub>2</sub>	d <sub>3</sub>	f <sub>1</sub>	f <sub>2</sub>	h <sub>1</sub>	h <sub>2</sub>	i	k	l <sub>1</sub>	l <sub>2</sub>	m <sub>2</sub>	m <sub>3</sub>	m <sub>4</sub>	n <sub>1</sub>	n <sub>2</sub>	x
	[kW]																					
050-025-125.1	0,55	0,63	-	-	80	219	110	200	158	427	160	140	135	162	507	357	65	155	176	225	130	115
050-025-125.1	-	-	0,75	-	80	219	110	200	158	427	160	140	135	162	507	357	65	155	176	225	130	115
050-025-125.1	-	-	1,10	1,27	80	219	110	200	158	459	160	140	135	162	539	389	65	155	176	225	130	115
050-025-125.1	-	-	1,50	1,75	80	219	110	200	158	512	160	140	135	190	592	442	65	155	176	225	130	115
050-025-125.1	-	-	2,20	2,55	80	219	110	200	158	512	160	140	135	190	592	442	65	155	176	225	130	115
050-025-125.1	-	-	3,00	3,45	80	219	110	250	168	558	160	140	135	213	638	488	65	155	176	225	130	115
050-025-125.1	-	-	4,00	4,55	80	219	110	250	168	540	160	140	135	235	620	470	65	155	176	225	130	115
050-025-125	0,55	0,63	-	-	80	219	110	200	158	427	160	140	135	162	507	357	65	155	176	225	130	115
050-025-125	-	-	0,75	-	80	219	110	200	158	427	160	140	135	162	507	357	65	155	176	225	130	115
050-025-125	-	-	1,10	-	80	219	110	200	158	459	160	140	135	162	539	389	65	155	176	225	130	115
050-025-125	-	-	1,50	1,75	80	219	110	200	158	512	160	140	135	190	592	442	65	155	176	225	130	115
050-025-125	-	-	2,20	2,55	80	219	110	200	158	512	160	140	135	190	592	442	65	155	176	225	130	115
050-025-125	-	-	3,00	3,45	80	219	110	250	168	558	160	140	135	213	638	488	65	155	176	225	130	115
050-025-125	-	-	4,00	4,55	80	219	110	250	168	540	160	140	135	235	620	470	65	155	176	225	130	115
050-025-160	0,55	0,63	-	-	80	254	127	200	158	427	160	160	135	162	507	357	65	155	176	236	130	115
050-025-160	-	0,86	-	-	80	254	127	200	158	459	160	160	135	162	539	389	65	155	176	236	130	115
050-025-160	-	1,27	-	-	80	254	127	200	158	512	160	160	135	190	592	442	65	155	176	236	130	115
050-025-160	-	-	1,50	-	80	254	127	200	158	512	160	160	135	190	592	442	65	155	176	236	130	115
050-025-160	-	-	2,20	2,55	80	254	127	200	158	512	160	160	135	190	592	442	65	155	176	236	130	115
050-025-160	-	-	3,00	3,45	80	254	127	250	168	558	160	160	135	213	638	488	65	155	176	236	130	115
050-025-160	-	-	4,00	4,55	80	254	127	250	168	540	160	160	135	235	620	470	65	155	176	236	130	115
050-025-200	0,55	-	-	-	80	284	142	200	158	427	160	180	135	162	507	357	65	155	176	264	130	115
050-025-200	0,75	0,86	-	-	80	284	142	200	158	459	160	180	135	162	539	389	65	155	176	264	130	115
050-025-200	1,10	1,27	-	-	80	284	142	200	158	512	160	180	135	190	592	442	65	155	176	264	130	115

<sup>24)</sup> Tolerances of mating dimensions to EN 735

Size	1450 rpm	1750 rpm	2900 rpm	3500 rpm	a	d <sub>1</sub>	d <sub>2</sub>	d <sub>3</sub>	f <sub>1</sub>	f <sub>2</sub> ~	h <sub>1</sub>	h <sub>2</sub>	i	k ~	l <sub>1</sub> ~	l <sub>2</sub> ~	m <sub>2</sub>	m <sub>3</sub>	m <sub>4</sub>	n <sub>1</sub>	n <sub>2</sub>	x
	[kW]				[mm] <sup>24)</sup>																	
050-025-200	-	1,75	-	-	80	284	142	200	158	512	160	180	135	190	592	442	65	155	176	264	130	115
050-025-200	-	2,55	-	-	80	284	142	250	168	558	160	180	135	213	638	488	65	155	176	264	130	115
050-025-200	-	-	3,00	-	80	284	142	250	168	558	160	180	135	213	638	488	65	155	176	264	130	115
050-025-200	-	-	4,00	4,55	80	284	142	250	168	540	160	180	135	235	620	470	65	155	176	264	130	115
050-025-250	0,75	-	-	-	100	348	174	200	156	457	180	225	118	162	557	369	30	110	140	225	130	130
050-025-250	1,10	1,27	-	-	100	348	174	200	156	510	180	225	118	190	610	422	30	110	140	225	130	130
050-025-250	1,50	1,75	-	-	100	348	174	200	156	510	180	225	118	190	610	422	30	110	140	225	130	130
050-025-250	-	2,55	-	-	100	348	174	250	170	560	180	225	118	213	660	472	30	110	140	225	130	130
050-025-250	-	3,45	-	-	100	348	174	250	170	560	180	225	118	213	660	472	30	110	140	225	130	130

Etachrom B 32, up to motor 112 (4.00 kW), with pump foot

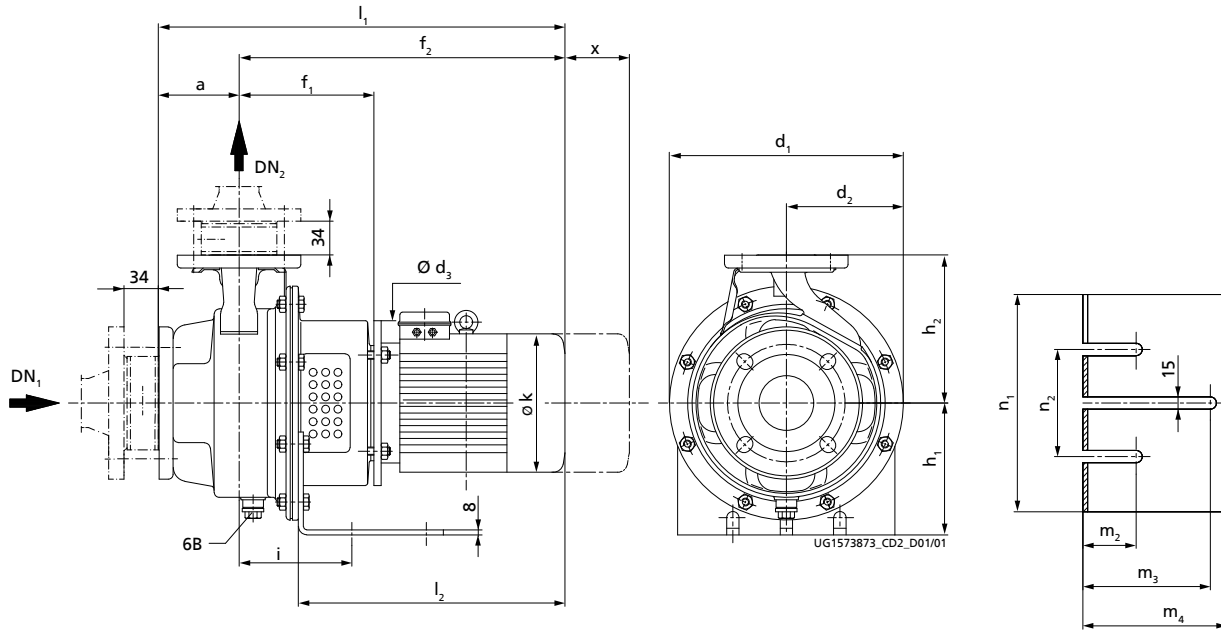

Fig. 5: Etachrom B with pump foot, dimensions [mm]

6B	Fluid drain	$G^{3/8}$ = ISO 228/1
----	-------------	-----------------------

DN = EN 1092-1/DN.../PN 16/B

Table 21: Dimensions

Size	1450 rpm	1750 rpm	2900 rpm	3500 rpm	a	$d_1$	$d_2$	$d_3$	$f_1$	$f_2$	$h_1$	$h_2$	i	k	$l_1$	$l_2$	$m_2$	$m_3$	$m_4$	$n_1$	$n_2$	x
	[kW]																					
050-032-125.1	0,55	0,63	-	-	80	219	110	200	158	427	160	140	135	162	507	357	65	155	176	225	130	115
050-032-125.1	-	0,86	-	-	80	219	110	200	158	459	160	140	135	162	539	389	65	155	176	225	130	115
050-032-125.1	-	-	0,75	-	80	219	110	200	158	427	160	140	135	162	507	357	65	155	176	225	130	115
050-032-125.1	-	-	1,10	-	80	219	110	200	158	459	160	140	135	162	539	389	65	155	176	225	130	115
050-032-125.1	-	-	1,50	1,75	80	219	110	200	158	512	160	140	135	190	592	442	65	155	176	225	130	115
050-032-125.1	-	-	-	2,55	80	219	110	200	158	512	160	140	135	190	592	442	65	155	176	225	130	115
050-032-125.1	-	-	-	3,45	80	219	110	250	168	558	160	140	135	213	638	488	65	155	176	225	130	115
050-032-125.1	-	-	-	4,55	80	219	110	250	168	540	160	140	135	235	620	470	65	155	176	225	130	115
050-032-125	0,55	0,63	-	-	80	219	110	200	158	427	160	140	135	162	507	357	65	155	176	225	130	115
050-032-125	-	0,86	-	-	80	219	110	200	158	459	160	140	135	162	539	389	65	155	176	225	130	115
050-032-125	-	-	1,50	-	80	219	110	200	158	512	160	140	135	190	592	442	65	155	176	225	130	115
050-032-125	-	-	2,20	2,55	80	219	110	200	158	512	160	140	135	190	592	442	65	155	176	225	130	115
050-032-125	-	-	3,00	3,45	80	219	110	250	168	558	160	140	135	213	638	488	65	155	176	225	130	115
050-032-125	-	-	-	4,55	80	219	110	250	168	540	160	140	135	235	620	470	65	155	176	225	130	115
050-032-160	0,55	0,63	-	-	80	254	127	200	158	427	160	160	135	162	507	357	65	155	176	236	130	115
050-032-160	0,75	0,86	-	-	80	254	127	200	158	459	160	160	135	162	539	389	65	155	176	236	130	115
050-032-160	-	1,27	-	-	80	254	127	200	158	512	160	160	135	190	592	442	65	155	176	236	130	115
050-032-160	-	1,75	-	-	80	254	127	200	158	512	160	160	135	190	592	442	65	155	176	236	130	115
050-032-160	-	-	2,20	-	80	254	127	200	158	512	160	160	135	190	592	442	65	155	176	236	130	115
050-032-160	-	-	3,00	3,45	80	254	127	250	168	558	160	160	135	213	638	488	65	155	176	236	130	115
050-032-160	-	-	4,00	4,55	80	254	127	250	168	540	160	160	135	235	620	470	65	155	176	236	130	115
050-032-200	0,55	-	-	-	80	284	142	200	158	427	160	180	135	162	507	357	65	155	176	264	130	115
050-032-200	0,75	-	-	-	80	284	142	200	158	459	160	180	135	162	539	389	65	155	176	264	130	115
050-032-200	1,10	1,27	-	-	80	284	142	200	158	512	160	180	135	190	592	442	65	155	176	264	130	115
050-032-200	-	1,75	-	-	80	284	142	200	158	512	160	180	135	190	592	442	65	155	176	264	130	115
050-032-200	-	2,55	-	-	80	284	142	250	168	558	160	180	135	213	638	488	65	155	176	264	130	115
050-032-200	-	-	3,00	-	80	284	142	250	168	558	160	180	135	213	638	488	65	155	176	264	130	115

<sup>25)</sup> Tolerances of mating dimensions to EN 735

Size	1450 rpm	1750 rpm	2900 rpm	3500 rpm	a	d <sub>1</sub>	d <sub>2</sub>	d <sub>3</sub>	f <sub>1</sub>	f <sub>2</sub> ~	h <sub>1</sub>	h <sub>2</sub>	i	k ~	l <sub>1</sub> ~	l <sub>2</sub> ~	m <sub>2</sub>	m <sub>3</sub>	m <sub>4</sub>	n <sub>1</sub>	n <sub>2</sub>	x
	[kW]				[mm] <sup>25)</sup>																	
050-032-200	-	-	4,00	-	80	284	142	250	168	540	160	180	135	235	620	470	65	155	176	264	130	115
050-032-250	0,75	-	-	-	100	348	174	200	156	457	180	225	118	162	557	369	30	110	140	225	130	130
050-032-250	1,10	-	-	-	100	348	174	200	156	510	180	225	118	190	610	422	30	110	140	225	130	130
050-032-250	1,50	1,75	-	-	100	348	174	200	156	510	180	225	118	190	610	422	30	110	140	225	130	130
050-032-250	2,20	2,55	-	-	100	348	174	250	170	560	180	225	118	213	660	472	30	110	140	225	130	130
050-032-250	3,00	3,45	-	-	100	348	174	250	170	560	180	225	118	213	660	472	30	110	140	225	130	130
050-032-250	-	4,55	-	-	100	348	174	250	170	542	180	225	118	235	642	454	30	110	140	225	130	130



Etachrom B 40, up to motor 112 (4.00 kW), with pump foot

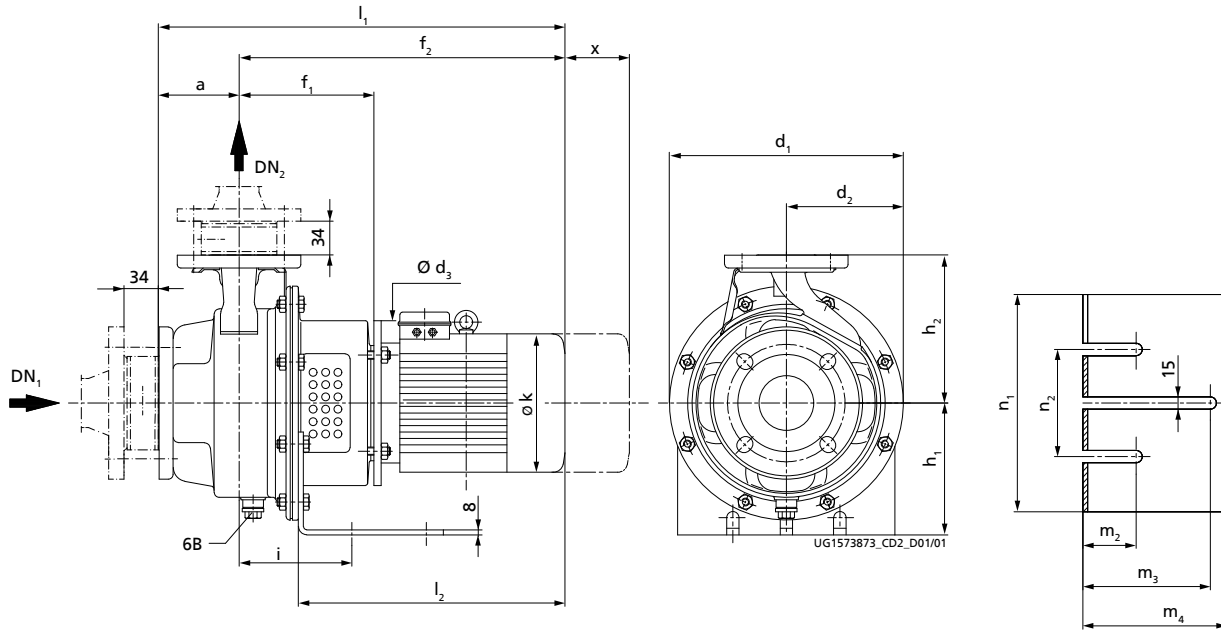

Fig. 6: Etachrom B with pump foot, dimensions [mm]

6B	Fluid drain	$G^{3/8}$ = ISO 228/1
----	-------------	-----------------------

DN = EN 1092-1/DN.../PN 16/B

Table 22: Dimensions

Size	1450 rpm	1750 rpm	2900 rpm	3500 rpm	a	$d_1$	$d_2$	$d_3$	$f_1$	$f_2$	$h_1$	$h_2$	i	k	$l_1$	$l_2$	$m_2$	$m_3$	$m_4$	$n_1$	$n_2$	x
	[kW]																					
065-040-125	0,55	0,63	-	-	80	219	110	200	160	429	160	140	137	162	509	357	65	155	176	225	130	115
065-040-125	-	0,86	-	-	80	219	110	200	160	461	160	140	137	162	541	389	65	155	176	225	130	115
065-040-125	-	1,27	-	-	80	219	110	200	160	514	160	140	137	190	594	442	65	155	176	225	130	115
065-040-125	-	-	1,50	-	80	219	110	200	160	514	160	140	137	190	594	442	65	155	176	225	130	115
065-040-125	-	-	2,20	2,55	80	219	110	200	160	514	160	140	137	190	594	442	65	155	176	225	130	115
065-040-125	-	-	3,00	3,45	80	219	110	250	170	560	160	140	137	213	640	488	65	155	176	225	130	115
065-040-125	-	-	4,00	4,55	80	219	110	250	170	542	160	140	137	235	622	470	65	155	176	225	130	115
065-040-160	0,55	-	-	-	80	254	127	200	160	429	160	160	137	162	509	357	65	155	176	236	130	115
065-040-160	0,75	-	-	-	80	254	127	200	160	461	160	160	137	162	541	389	65	155	176	236	130	115
065-040-160	1,10	1,27	-	-	80	254	127	200	160	514	160	160	137	190	594	442	65	155	176	236	130	115
065-040-160	1,50	1,75	-	-	80	254	127	200	160	514	160	160	137	190	594	442	65	155	176	236	130	115
065-040-160	-	2,55	-	-	80	254	127	250	170	560	160	160	137	213	640	488	65	155	176	236	130	115
065-040-160	-	-	3,00	-	80	254	127	250	170	560	160	160	137	213	640	488	65	155	176	236	130	115
065-040-160	-	-	4,00	-	80	254	127	250	170	542	160	160	137	235	622	470	65	155	176	236	130	115
065-040-200	0,75	-	-	-	100	284	142	200	160	461	160	180	137	162	561	389	65	155	176	264	130	115
065-040-200	1,10	1,27	-	-	100	284	142	200	160	514	160	180	137	190	614	442	65	155	176	264	130	115
065-040-200	1,50	1,75	-	-	100	284	142	200	160	514	160	180	137	190	614	442	65	155	176	264	130	115
065-040-200	-	2,55	-	-	100	284	142	250	170	560	160	180	137	213	660	488	65	155	176	264	130	115
065-040-200	-	3,45	-	-	100	284	142	250	170	560	160	180	137	213	660	488	65	155	176	264	130	115
065-040-250	1,10	-	-	-	100	348	174	200	156	510	180	225	118	190	610	422	30	110	140	225	130	130
065-040-250	1,50	1,75	-	-	100	348	174	200	156	510	180	225	118	190	610	422	30	110	140	225	130	130
065-040-250	2,20	2,55	-	-	100	348	174	250	170	560	180	225	118	213	660	472	30	110	140	225	130	130
065-040-250	3,00	3,45	-	-	100	348	174	250	170	560	180	225	118	213	660	472	30	110	140	225	130	130
065-040-250	-	4,55	-	-	100	348	174	250	170	542	180	225	118	235	642	454	30	110	140	225	130	130

1213.5/30-EN

<sup>26)</sup> Tolerances of mating dimensions to EN 735

Etachrom B 50, up to motor 112 (4.00 kW), with pump foot

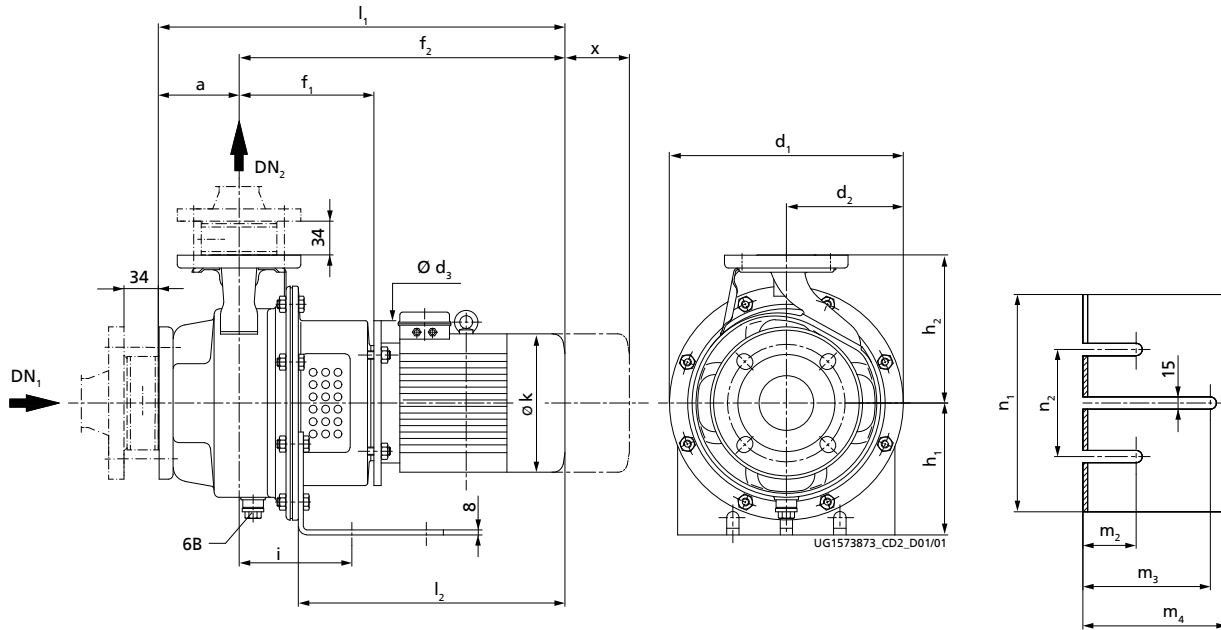

Fig. 7: Etachrom B with pump foot, dimensions [mm]

6B	Fluid drain	G <sup>3/8</sup> = ISO 228/1
----	-------------	------------------------------

DN = EN 1092-1/DN.../PN 16/B

Table 23: Dimensions

Size	1450 rpm	1750 rpm	2900 rpm	3500 rpm	a	d <sub>1</sub>	d <sub>2</sub>	d <sub>3</sub>	f <sub>1</sub>	f <sub>2</sub>	h <sub>1</sub>	h <sub>2</sub>	i	k	l <sub>1</sub>	l <sub>2</sub>	m <sub>2</sub>	m <sub>3</sub>	m <sub>4</sub>	n <sub>1</sub>	n <sub>2</sub>	x
	[kW]																					
065-050-125	0,55	-	-	-	100	254	127	200	160	429	160	160	137	162	529	357	65	155	176	236	130	130
065-050-125	0,75	0,86	-	-	100	254	127	200	160	461	160	160	137	162	561	389	65	155	176	236	130	130
065-050-125	1,10	1,27	-	-	100	254	127	200	160	514	160	160	137	190	614	442	65	155	176	236	130	130
065-050-125	-	1,75	-	-	100	254	127	200	160	514	160	160	137	190	614	442	65	155	176	236	130	130
065-050-125	-	-	3,00	-	100	254	127	250	170	560	160	160	137	213	660	488	65	155	176	236	130	130
065-050-125	-	-	4,00	-	100	254	127	250	170	542	160	160	137	235	642	470	65	155	176	236	130	130
065-050-160	0,75	-	-	-	100	254	127	200	160	461	160	180	137	162	561	389	65	155	176	236	130	130
065-050-160	1,10	1,27	-	-	100	254	127	200	160	514	160	180	137	190	614	442	65	155	176	236	130	130
065-050-160	1,50	1,75	-	-	100	254	127	200	160	514	160	180	137	190	614	442	65	155	176	236	130	130
065-050-160	2,20	2,55	-	-	100	254	127	250	170	560	160	180	137	213	660	488	65	155	176	236	130	130
065-050-160	-	3,45	-	-	100	254	127	250	170	560	160	180	137	213	660	488	65	155	176	236	130	130
065-050-200	0,75	-	-	-	100	313	157	200	156	457	180	200	118	162	557	369	30	110	140	225	130	130
065-050-200	1,10	-	-	-	100	313	157	200	156	510	180	200	118	190	610	422	30	110	140	225	130	130
065-050-200	1,50	1,75	-	-	100	313	157	200	156	510	180	200	118	190	610	422	30	110	140	225	130	130
065-050-200	2,20	2,55	-	-	100	313	157	250	170	560	180	200	118	213	660	472	30	110	140	225	130	130
065-050-200	3,00	3,45	-	-	100	313	157	250	170	560	180	200	118	213	660	472	30	110	140	225	130	130
065-050-200	4,00	4,55	-	-	100	313	157	250	170	542	180	200	118	235	642	454	30	110	140	225	130	130
065-050-250	1,50	-	-	-	100	348	174	200	156	510	180	225	118	190	610	422	30	110	140	225	130	130
065-050-250	2,20	2,55	-	-	100	348	174	250	170	560	180	225	118	213	660	472	30	110	140	225	130	130
065-050-250	3,00	3,45	-	-	100	348	174	250	170	560	180	225	118	213	660	472	30	110	140	225	130	130
065-050-250	4,00	4,55	-	-	100	348	174	250	170	542	180	225	118	235	642	454	30	110	140	225	130	130

<sup>27)</sup> Tolerances of mating dimensions to EN 735

Etachrom B 65, up to motor 112 (4.00 kW), with pump foot

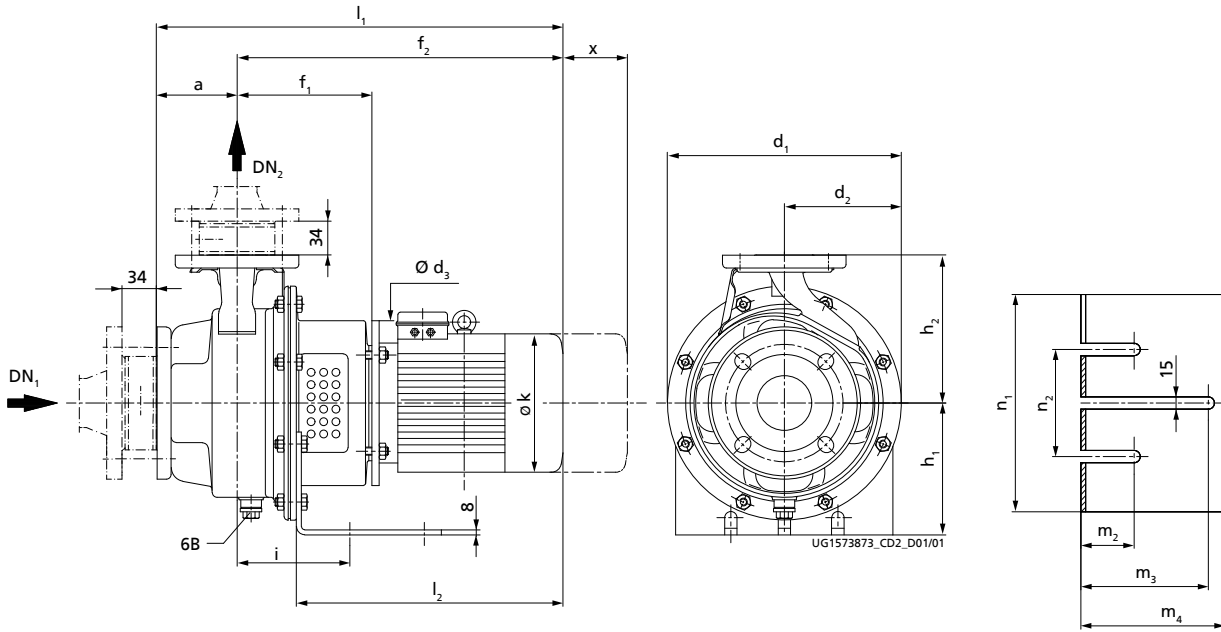

Fig. 8: Etachrom B with pump foot, dimensions [mm]

6B	Fluid drain	G <sup>3/8</sup> = ISO 228/1
----	-------------	------------------------------

DN = EN 1092-1/DN.../PN 16/B

Table 24: Dimensions

Size	1450 rpm	1750 rpm	2900 rpm	3500 rpm	a	d <sub>1</sub>	d <sub>2</sub>	d <sub>3</sub>	f <sub>1</sub>	f <sub>2</sub> ~	h <sub>1</sub>	h <sub>2</sub>	i	k ~	l <sub>1</sub> ~	l <sub>2</sub> ~	m <sub>2</sub>	m <sub>3</sub>	m <sub>4</sub>	n <sub>1</sub>	n <sub>2</sub>	x
	[kW]																					
080-065-200	1,50	-	-	-	100	348	174	200	156	510	180	225	118	190	610	422	30	110	140	225	130	130
080-065-200	2,20	2,55	-	-	100	348	174	250	170	560	180	225	118	213	660	472	30	110	140	225	130	130
080-065-200	3,00	3,45	-	-	100	348	174	250	170	560	180	225	118	213	660	472	30	110	140	225	130	130
080-065-200	4,00	4,55	-	-	100	348	174	250	170	542	180	225	118	235	642	454	30	110	140	225	130	130
080-065-250	2,20	-	-	-	100	348	174	250	190	580	180	250	145	213	680	465	30	120	160	260	180	140
080-065-250	3,00	-	-	-	100	348	174	250	190	580	180	250	145	213	680	465	30	120	160	260	180	140
080-065-250	4,00	4,55	-	-	100	348	174	250	190	562	180	250	145	235	662	447	30	120	160	260	180	140

<sup>28)</sup> Tolerances of mating dimensions to EN 735

Etachrom B 80, up to motor 112 (4.00 kW), with pump foot

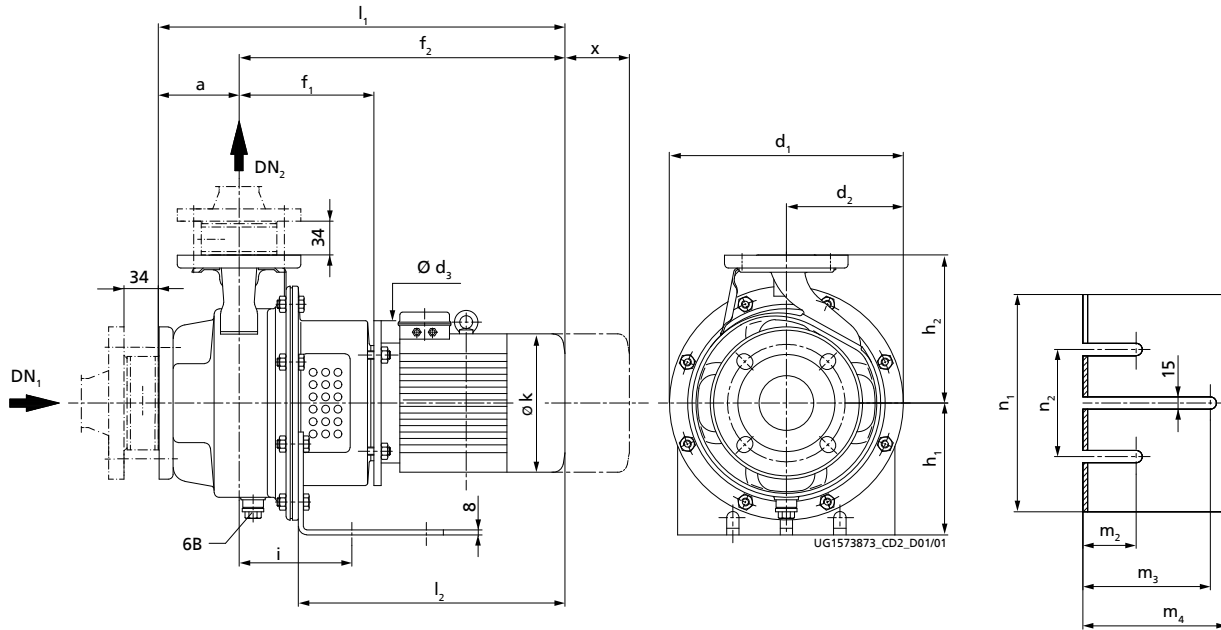

Fig. 9: Etachrom B with pump foot, dimensions [mm]

6B	Fluid drain	G <sup>3/8</sup> = ISO 228/1
----	-------------	------------------------------

DN = EN 1092-1/DN.../PN 16/B

Table 25: Dimensions

Size	1450 rpm	1750 rpm	2900 rpm	3500 rpm	a	d <sub>1</sub>	d <sub>2</sub>	d <sub>3</sub>	f <sub>1</sub>	f <sub>2</sub> ~	h <sub>1</sub>	h <sub>2</sub>	i	k ~	l <sub>1</sub> ~	l <sub>2</sub> ~	m <sub>2</sub>	m <sub>3</sub>	m <sub>4</sub>	n <sub>1</sub>	n <sub>2</sub>	x
	[kW]																					
100-080-200	2,20	-	-	-	125	348	174	250	190	580	180	250	145	213	705	465	30	120	160	260	180	150
100-080-200	3,00	3,45	-	-	125	348	174	250	190	580	180	250	145	213	705	465	30	120	160	260	180	150
100-080-200	4,00	4,55	-	-	125	348	174	250	190	562	180	250	145	235	687	447	30	120	160	260	180	150
100-080-250	3,00	-	-	-	125	348	174	250	190	580	180	280	145	213	705	465	30	120	160	260	180	150
100-080-250	4,00	-	-	-	125	348	174	250	190	562	180	280	145	235	687	447	30	120	160	260	180	150

<sup>29)</sup> Tolerances of mating dimensions to EN 735

Etachrom B 25, with levelling feet and motor shroud

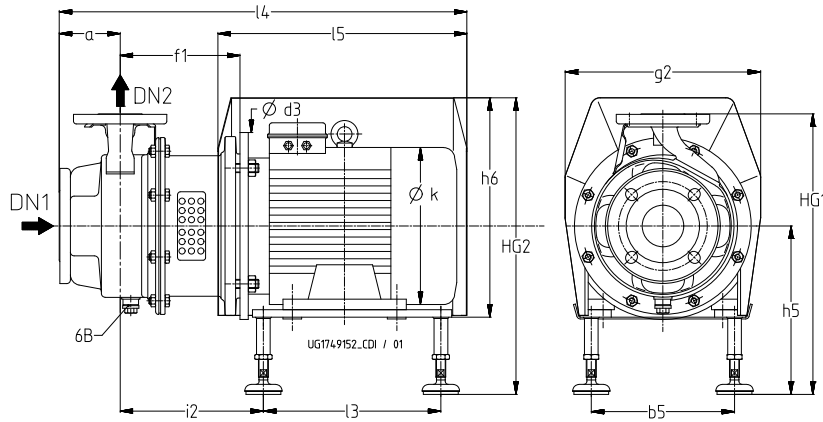

Etachrom B with levelling feet, with motor shroud

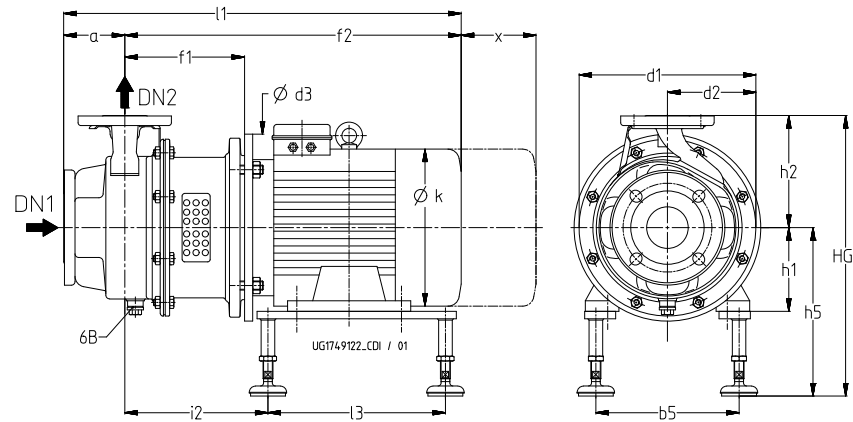

Etachrom B with levelling feet, without motor shroud

Table 26: Dimensions<sup>30)</sup>

Size	1450 rpm	1750 rpm	2900 rpm	3500 rpm	Motor	a	b <sub>5</sub>	d <sub>1</sub>	d <sub>2</sub>	d <sub>3</sub>	f <sub>1</sub>	f <sub>2</sub>	g <sub>2</sub>	h <sub>1</sub>	h <sub>2</sub>	h <sub>5</sub> min.	h <sub>5</sub> max.	h <sub>6</sub>	HG <sub>1</sub> max.	HG <sub>2</sub> max.	i <sub>2</sub>	k	l <sub>1</sub>	l <sub>3</sub>	l <sub>4</sub>	l <sub>5</sub>	x
	[kW]																										
050-025-125.1	0,55	0,63	-	-	80M	80	200	219	110	200	158	427	264	80	140	224	246	305	386	446	156	162	507	205	645	450	115
050-025-125.1	-	-	0,75	-	80M	80	200	219	110	200	158	427	264	80	140	224	246	305	386	446	156	162	507	205	645	450	115
050-025-125.1	-	-	1,10	1,27	80M	80	200	219	110	200	158	459	264	80	140	224	246	305	386	446	156	162	539	205	645	450	115
050-025-125.1	-	-	1,50	1,75	90S	80	200	219	110	200	158	512	264	90	140	234	256	305	396	446	152	190	592	225	651	450	115
050-025-125.1	-	-	2,20	2,55	90L	80	200	219	110	200	158	512	264	90	140	234	256	305	396	446	164	190	592	225	651	450	115
050-025-125.1	-	-	3,00	3,45	100L	80	200	219	110	250	168	558	264	100	140	244	266	305	406	446	169	213	638	265	691	470	115
050-025-125.1	-	-	4,00	4,55	112M	80	200	219	110	250	168	540	264	112	140	243	265	305	405	446	176	235	620	265	687	470	115
050-025-125	0,55	0,63	-	-	80M	80	200	219	110	200	158	427	264	80	140	224	246	305	386	446	156	162	507	205	645	450	115
050-025-125	-	-	0,75	-	80M	80	200	219	110	200	158	427	264	80	140	224	246	305	386	446	156	162	507	205	645	450	115
050-025-125	-	-	1,10	-	80M	80	200	219	110	200	158	459	264	80	140	224	246	305	386	446	156	162	539	205	645	450	115
050-025-125	-	-	1,50	1,75	90S	80	200	219	110	200	158	512	264	90	140	234	256	305	396	446	152	190	592	225	651	450	115
050-025-125	-	-	2,20	2,55	90L	80	200	219	110	200	158	512	264	90	140	234	256	305	396	446	164	190	592	225	651	450	115
050-025-125	-	-	3,00	3,45	100L	80	200	219	110	250	168	558	264	100	140	244	266	305	406	446	169	213	638	265	691	470	115
050-025-125	-	-	4,00	4,55	112M	80	200	219	110	250	168	540	264	112	140	243	265	305	405	446	176	235	620	265	687	470	115
050-025-160	0,55	0,63	-	-	80M	80	200	254	127	200	158	427	264	80	160	224	246	305	406	446	156	162	507	205	645	450	115

<sup>30)</sup> Tolerances of mating dimensions to EN 735

Size	1450 rpm	1750 rpm	2900 rpm	3500 rpm	Motor	a	b <sub>5</sub>	d <sub>1</sub>	d <sub>2</sub>	d <sub>3</sub>	f <sub>1</sub>	f <sub>2</sub>	g <sub>2</sub>	h <sub>1</sub>	h <sub>2</sub>	h <sub>5</sub> min.	h <sub>5</sub> max.	h <sub>6</sub>	HG <sub>1</sub> max.	HG <sub>2</sub> max.	i <sub>2</sub>	k	l <sub>1</sub>	l <sub>3</sub>	l <sub>4</sub>	l <sub>5</sub>	x
	[kW]					[mm]																					
050-025-160	-	0,86	-	-	80M	80	200	254	127	200	158	459	264	80	160	224	246	305	406	446	156	162	539	205	645	450	115
050-025-160	-	1,27	-	-	90S	80	200	254	127	200	158	512	264	90	160	234	256	305	416	446	152	190	592	225	651	450	115
050-025-160	-	-	1,50	-	90S	80	200	254	127	200	158	512	264	90	160	234	256	305	416	446	152	190	592	225	651	450	115
050-025-160	-	-	2,20	2,55	90L	80	200	254	127	200	158	512	264	90	160	234	256	305	416	446	164	190	592	225	651	450	115
050-025-160	-	-	3,00	3,45	100L	80	200	254	127	250	168	558	264	100	160	244	266	305	426	446	169	213	638	265	691	470	115
050-025-160	-	-	4,00	4,55	112M	80	200	254	127	250	168	540	264	112	160	243	265	305	425	446	176	235	620	265	687	470	115
050-025-160	-	-	-	6,30	132S	80	230	254	127	300	188	601	314	132	160	263	285	350	445	491	205	274	681	285	787	550	115
050-025-160	-	-	-	8,60	132S	80	230	254	127	300	188	645	314	132	160	263	285	350	445	491	205	274	725	285	787	550	115
050-025-200	0,55	-	-	-	80M	80	200	284	142	200	158	427	264	80	180	224	246	305	426	446	156	162	507	205	645	450	115
050-025-200	0,75	0,86	-	-	80M	80	200	284	142	200	158	459	264	80	180	224	246	305	426	446	156	162	539	205	645	450	115
050-025-200	1,10	1,27	-	-	90S	80	200	284	142	200	158	512	264	90	180	234	256	305	436	446	152	190	592	225	651	450	115
050-025-200	-	1,75	-	-	90L	80	200	284	142	200	158	512	264	90	180	234	256	305	436	446	164	190	592	225	651	450	115
050-025-200	-	2,55	-	-	100L	80	200	284	142	250	168	558	264	100	180	244	266	305	446	446	169	213	638	265	691	470	115
050-025-200	-	-	3,00	-	100L	80	200	284	142	250	168	558	264	100	180	244	266	305	446	446	169	213	638	265	691	470	115
050-025-200	-	-	4,00	4,55	112M	80	200	284	142	250	168	540	264	112	180	243	265	305	445	446	176	235	620	265	687	470	115
050-025-200	-	-	5,50	6,30	132S	80	230	284	142	300	188	601	314	132	180	263	285	350	465	491	205	274	681	285	787	550	115
050-025-200	-	-	7,50	8,60	132S	80	230	284	142	300	188	645	314	132	180	263	285	350	465	491	205	274	725	285	787	550	115
050-025-200	-	-	-	12,60	160M	80	280	284	142	350	218	764	372	160	180	291	313	423	493	564	239	325	844	385	965	720	115
050-025-200	-	-	-	17,30	160M	80	280	284	142	350	218	764	372	160	180	291	313	423	493	564	239	325	844	385	965	720	115
050-025-250	0,75	-	-	-	80M	100	200	348	174	200	156	457	264	80	225	236	246	305	471	446	99	162	557	260	663	450	130
050-025-250	1,10	1,27	-	-	90S	100	200	348	174	200	156	510	264	90	225	246	256	305	481	446	95	190	610	280	669	450	130
050-025-250	1,50	1,75	-	-	90L	100	200	348	174	200	156	510	264	90	225	246	256	305	481	446	107	190	610	280	669	450	130
050-025-250	-	2,55	-	-	100L	100	200	348	174	250	170	560	264	100	225	256	266	305	491	446	126	213	660	310	713	470	130
050-025-250	-	3,45	-	-	100L	100	200	348	174	250	170	560	264	100	225	256	266	305	491	446	126	213	660	310	713	470	130
050-025-250	-	-	5,50	-	132S	100	230	348	174	300	193	606	314	132	225	275	285	350	510	491	150	274	706	345	812	550	130
050-025-250	-	-	7,50	-	132S	100	230	348	174	300	193	650	314	132	225	275	285	350	510	491	150	274	750	345	812	550	130
050-025-250	-	-	11,00	-	160M	100	280	348	174	350	226	772	372	160	225	291	313	423	538	564	247	325	872	385	993	720	130
050-025-250	-	-	15,00	-	160M	100	280	348	174	350	226	772	372	160	225	291	313	423	538	564	247	325	872	385	993	720	130

Etachrom B 32, with levelling feet and motor shroud

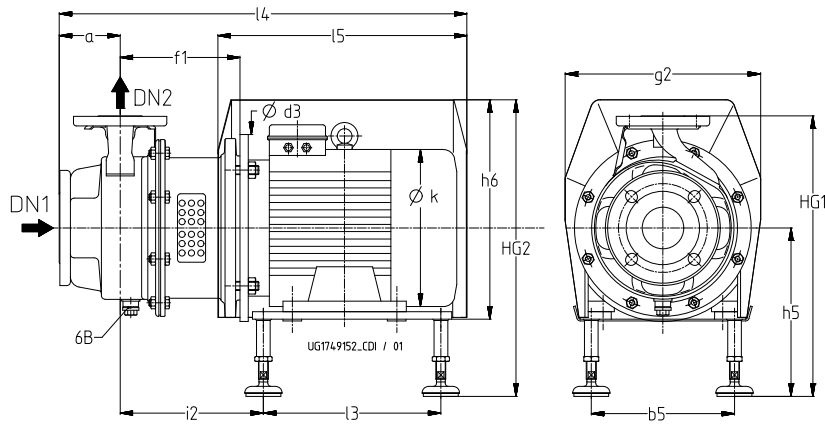

Etachrom B with levelling feet, with motor shroud

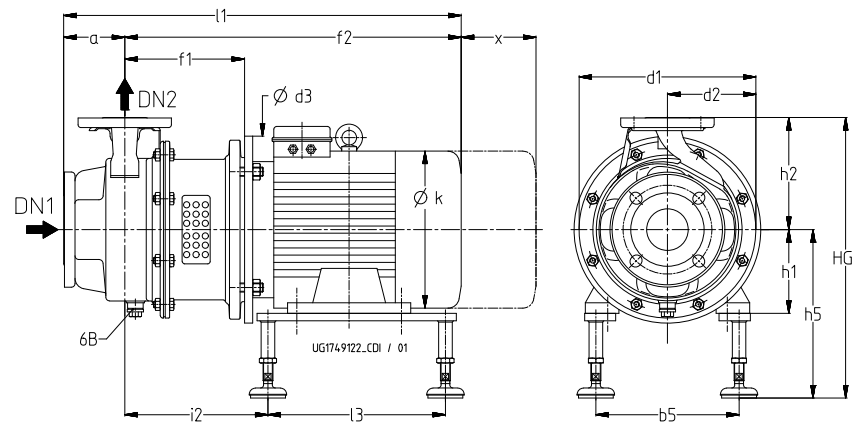

Etachrom B with levelling feet, without motor shroud

Table 27: Dimensions

Size	1450 rpm	1750 rpm	2900 rpm	3500 rpm	Motor	a	b <sub>5</sub>	d <sub>1</sub>	d <sub>2</sub>	d <sub>3</sub>	f <sub>1</sub>	f <sub>2</sub>	g <sub>2</sub>	h <sub>1</sub>	h <sub>2</sub>	h <sub>5</sub> min.	h <sub>5</sub> max.	h <sub>6</sub>	HG <sub>1</sub> max.	HG <sub>2</sub> max.	i <sub>2</sub>	k	l <sub>1</sub>	l <sub>3</sub>	l <sub>4</sub>	l <sub>5</sub>	x
	[kW]																										
050-032-125.1	0,55	0,63	-	-	80M	80	200	219	110	200	158	427	264	80	140	224	246	305	386	446	156	162	507	205	645	450	115
050-032-125.1	-	0,86	-	-	80M	80	200	219	110	200	158	459	264	80	140	224	246	305	386	446	156	162	539	205	645	450	115
050-032-125.1	-	-	0,75	-	80M	80	200	219	110	200	158	427	264	80	140	224	246	305	386	446	156	162	507	205	645	450	115
050-032-125.1	-	-	1,10	-	80M	80	200	219	110	200	158	459	264	80	140	224	246	305	386	446	156	162	539	205	645	450	115
050-032-125.1	-	-	1,50	1,75	90S	80	200	219	110	200	158	512	264	90	140	234	256	305	396	446	152	190	592	225	651	450	115
050-032-125.1	-	-	-	2,55	90L	80	200	219	110	200	158	512	264	90	140	234	256	305	396	446	164	190	592	225	651	450	115
050-032-125.1	-	-	-	3,45	100L	80	200	219	110	250	168	558	264	100	140	244	266	305	406	446	169	213	638	265	691	470	115
050-032-125.1	-	-	-	4,55	112M	80	200	219	110	250	168	540	264	112	140	243	265	305	405	446	176	235	620	265	687	470	115
050-032-125	0,55	0,63	-	-	80M	80	200	219	110	200	158	427	264	80	140	224	246	305	386	446	156	162	507	205	645	450	115
050-032-125	-	0,86	-	-	80M	80	200	219	110	200	158	459	264	80	140	224	246	305	386	446	156	162	539	205	645	450	115
050-032-125	-	-	1,50	-	90S	80	200	219	110	200	158	512	264	90	140	234	256	305	396	446	152	190	592	225	651	450	115
050-032-125	-	-	2,20	2,55	90L	80	200	219	110	200	158	512	264	90	140	234	256	305	396	446	164	190	592	225	651	450	115
050-032-125	-	-	3,00	3,45	100L	80	200	219	110	250	168	558	264	100	140	244	266	305	406	446	169	213	638	265	691	470	115
050-032-125	-	-	-	4,55	112M	80	200	219	110	250	168	540	264	112	140	243	265	305	405	446	176	235	620	265	687	470	115
050-032-160	0,55	0,63	-	-	80M	80	200	254	127	200	158	427	264	80	160	224	246	305	406	446	156	162	507	205	645	450	115

<sup>31)</sup> Tolerances of mating dimensions to EN 735

Size	1450 rpm	1750 rpm	2900 rpm	3500 rpm	Motor	a	b <sub>5</sub>	d <sub>1</sub>	d <sub>2</sub>	d <sub>3</sub>	f <sub>1</sub>	f <sub>2</sub>	g <sub>2</sub>	h <sub>1</sub>	h <sub>2</sub>	h <sub>5</sub> min.	h <sub>5</sub> max.	h <sub>6</sub>	HG <sub>1</sub> max.	HG <sub>2</sub> max.	i <sub>2</sub>	k	l <sub>1</sub>	l <sub>3</sub>	l <sub>4</sub>	l <sub>5</sub>	x
	[kW]					[mm] <sup>21)</sup>																					
050-032-160	0,75	0,86	-	-	80M	80	200	254	127	200	158	459	264	80	160	224	246	305	406	446	156	162	539	205	645	450	115
050-032-160	-	1,27	-	-	90S	80	200	254	127	200	158	512	264	90	160	234	256	305	416	446	152	190	592	225	651	450	115
050-032-160	-	1,75	-	-	90L	80	200	254	127	200	158	512	264	90	160	234	256	305	416	446	164	190	592	225	651	450	115
050-032-160	-	-	2,20	-	90L	80	200	254	127	200	158	512	264	90	160	234	256	305	416	446	164	190	592	225	651	450	115
050-032-160	-	-	3,00	3,45	100L	80	200	254	127	250	168	558	264	100	160	244	266	305	426	446	169	213	638	265	691	470	115
050-032-160	-	-	4,00	4,55	112M	80	200	254	127	250	168	540	264	112	160	243	265	305	425	446	176	235	620	265	687	470	115
050-032-160	-	-	5,50	6,30	132S	80	230	254	127	300	188	601	314	132	160	263	285	350	445	491	205	274	681	285	787	550	115
050-032-160	-	-	-	8,60	132S	80	230	254	127	300	188	645	314	132	160	263	285	350	445	491	205	274	725	285	787	550	115
050-032-160	-	-	-	12,60	160M	80	280	254	127	350	218	764	372	160	160	291	313	423	473	564	239	325	844	385	965	720	115
050-032-200	0,55	-	-	-	80M	80	200	284	142	200	158	427	264	80	180	224	246	305	426	446	156	162	507	205	645	450	115
050-032-200	0,75	-	-	-	80M	80	200	284	142	200	158	459	264	80	180	224	246	305	426	446	156	162	539	205	645	450	115
050-032-200	1,10	1,27	-	-	90S	80	200	284	142	200	158	512	264	90	180	234	256	305	436	446	152	190	592	225	651	450	115
050-032-200	-	1,75	-	-	90L	80	200	284	142	200	158	512	264	90	180	234	256	305	436	446	164	190	592	225	651	450	115
050-032-200	-	2,55	-	-	100L	80	200	284	142	250	168	558	264	100	180	244	266	305	446	446	169	213	638	265	691	470	115
050-032-200	-	-	3,00	-	100L	80	200	284	142	250	168	558	264	100	180	244	266	305	446	446	169	213	638	265	691	470	115
050-032-200	-	-	4,00	-	112M	80	200	284	142	250	168	540	264	112	180	243	265	305	445	446	176	235	620	265	687	470	115
050-032-200	-	-	5,50	6,30	132S	80	230	284	142	300	188	601	314	132	180	263	285	350	465	491	205	274	681	285	787	550	115
050-032-200	-	-	7,50	8,60	132S	80	230	284	142	300	188	645	314	132	180	263	285	350	465	491	205	274	725	285	787	550	115
050-032-200	-	-	11,00	12,60	160M	80	280	284	142	350	218	764	372	160	180	291	313	423	493	564	239	325	844	385	965	720	115
050-032-200	-	-	-	17,30	160M	80	280	284	142	350	218	764	372	160	180	291	313	423	493	564	239	325	844	385	965	720	115
050-032-250	0,75	-	-	-	80M	100	200	348	174	200	156	457	264	80	225	236	246	305	471	446	99	162	557	260	663	450	130
050-032-250	1,10	-	-	-	90S	100	200	348	174	200	156	510	264	90	225	246	256	305	481	446	95	190	610	280	669	450	130
050-032-250	1,50	1,75	-	-	90L	100	200	348	174	200	156	510	264	90	225	246	256	305	481	446	107	190	610	280	669	450	130
050-032-250	2,20	2,55	-	-	100L	100	200	348	174	250	170	560	264	100	225	256	266	305	491	446	126	213	660	310	713	470	130
050-032-250	3,00	3,45	-	-	100L	100	200	348	174	250	170	560	264	100	225	256	266	305	491	446	126	213	660	310	713	470	130
050-032-250	-	4,55	-	-	112M	100	200	348	174	250	170	542	264	112	225	255	265	305	490	446	113	235	642	330	709	470	130
050-032-250	-	6,30	-	-	132S	100	230	348	174	300	193	650	314	132	225	275	285	350	510	491	150	274	750	345	812	550	130
050-032-250	-	-	5,50	-	132S	100	230	348	174	300	193	606	314	132	225	275	285	350	510	491	150	274	706	345	812	550	130
050-032-250	-	-	7,50	-	132S	100	230	348	174	300	193	650	314	132	225	275	285	350	510	491	150	274	750	345	812	550	130
050-032-250	-	-	11,00	-	160M	100	280	348	174	350	226	772	372	160	225	291	313	423	538	564	247	325	872	385	993	720	130
050-032-250	-	-	15,00	-	160M	100	280	348	174	350	226	772	372	160	225	291	313	423	538	564	247	325	872	385	993	720	130
050-032-250	-	-	18,50	-	160L	100	280	348	174	350	226	808	372	160	225	291	313	423	538	564	269	325	908	385	993	720	130



Etachrom B 40, with levelling feet and motor shroud

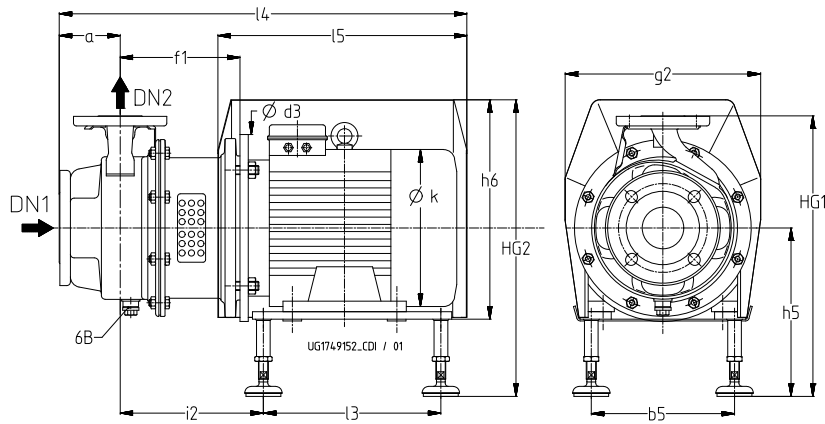

Etachrom B with levelling feet, with motor shroud

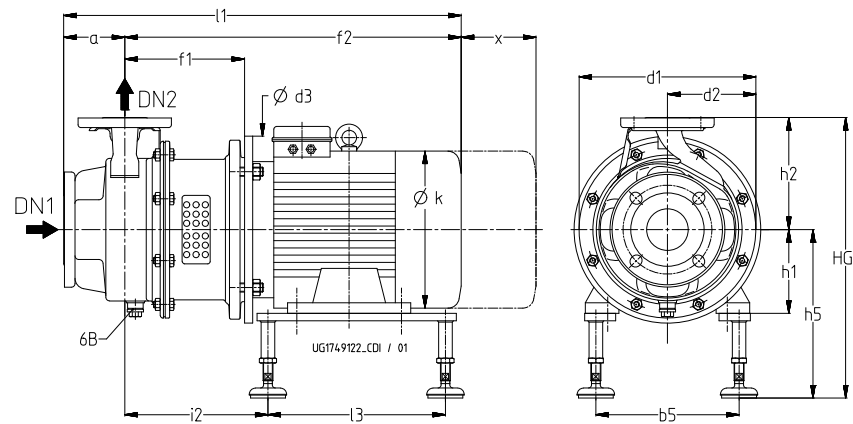

Etachrom B with levelling feet, without motor shroud

Table 28: Dimensions<sup>32)</sup>

Size	1450 rpm	1750 rpm	2900 rpm	3500 rpm	Motor	a	b <sub>5</sub>	d <sub>1</sub>	d <sub>2</sub>	d <sub>3</sub>	f <sub>1</sub>	f <sub>2</sub>	g <sub>2</sub>	h <sub>1</sub>	h <sub>2</sub>	h <sub>5</sub> min.	h <sub>5</sub> max.	h <sub>6</sub>	HG <sub>1</sub> max.	HG <sub>2</sub> max.	i <sub>2</sub>	k	l <sub>1</sub>	l <sub>3</sub>	l <sub>4</sub>	l <sub>5</sub>	x
	[kW]					[mm]																					
065-040-125	0,55	0,63	-	-	80M	80	200	219	110	200	160	429	264	80	140	224	246	305	386	446	158	162	509	205	647	450	115
065-040-125	-	0,86	-	-	80M	80	200	219	110	200	160	461	264	80	140	224	246	305	386	446	158	162	541	205	647	450	115
065-040-125	-	1,27	-	-	90S	80	200	219	110	200	160	514	264	90	140	234	256	305	396	446	154	190	594	225	653	450	115
065-040-125	-	-	1,50	-	90S	80	200	219	110	200	160	514	264	90	140	234	256	305	396	446	154	190	594	225	653	450	115
065-040-125	-	-	2,20	2,55	90L	80	200	219	110	200	160	514	264	90	140	234	256	305	396	446	166	190	594	225	653	450	115
065-040-125	-	-	3,00	3,45	100L	80	200	219	110	250	170	560	264	100	140	244	266	305	406	446	171	213	640	265	693	470	115
065-040-125	-	-	4,00	4,55	112M	80	200	219	110	250	170	542	264	112	140	243	265	305	405	446	178	235	622	265	689	470	115
065-040-160	0,55	-	-	-	80M	80	200	254	127	200	160	429	264	80	160	224	246	305	406	446	158	162	509	205	647	450	115
065-040-160	0,75	-	-	-	80M	80	200	254	127	200	160	461	264	80	160	224	246	305	406	446	158	162	541	205	647	450	115
065-040-160	1,10	1,27	-	-	90S	80	200	254	127	200	160	514	264	90	160	234	256	305	416	446	154	190	594	225	653	450	115
065-040-160	1,50	1,75	-	-	90L	80	200	254	127	200	160	514	264	90	160	234	256	305	416	446	166	190	594	225	653	450	115
065-040-160	-	2,55	-	-	100L	80	200	254	127	250	170	560	264	100	160	244	266	305	426	446	171	213	640	265	693	470	115
065-040-160	-	-	3,00	-	100L	80	200	254	127	250	170	560	264	100	160	244	266	305	426	446	171	213	640	265	693	470	115
065-040-160	-	-	4,00	-	112M	80	200	254	127	250	170	542	264	112	160	243	265	305	425	446	178	235	622	265	689	470	115
065-040-160	-	-	5,50	6,30	132S	80	230	254	127	300	190	603	314	132	160	263	285	350	445	491	207	274	683	285	789	550	115

<sup>32)</sup> Tolerances of mating dimensions to EN 735

Size	1450 rpm	1750 rpm	2900 rpm	3500 rpm	Motor	a	b <sub>5</sub>	d <sub>1</sub>	d <sub>2</sub>	d <sub>3</sub>	f <sub>1</sub>	f <sub>2</sub>	g <sub>2</sub>	h <sub>1</sub>	h <sub>2</sub>	h <sub>5</sub> min.	h <sub>5</sub> max.	h <sub>6</sub>	HG <sub>1</sub> max.	HG <sub>2</sub> max.	i <sub>2</sub>	k	l <sub>1</sub>	l <sub>3</sub>	l <sub>4</sub>	l <sub>5</sub>	x
	[kW]					[mm]																					
065-040-160	-	-	7,50	8,60	132S	80	230	254	127	300	190	647	314	132	160	263	285	350	445	491	207	274	727	285	789	550	115
065-040-160	-	-	11,00	12,60	160M	80	280	254	127	350	220	766	372	160	160	291	313	423	473	564	241	325	846	385	967	720	115
065-040-160	-	-	-	17,30	160M	80	280	254	127	350	220	766	372	160	160	291	313	423	473	564	241	325	846	385	967	720	115
065-040-200	0,75	-	-	-	80M	100	200	284	142	200	160	461	264	80	180	224	246	305	426	446	158	162	561	205	667	450	115
065-040-200	1,10	1,27	-	-	90S	100	200	284	142	200	160	514	264	90	180	234	256	305	436	446	154	190	614	225	673	450	115
065-040-200	1,50	1,75	-	-	90L	100	200	284	142	200	160	514	264	90	180	234	256	305	436	446	166	190	614	225	673	450	115
065-040-200	-	2,55	-	-	100L	100	200	284	142	250	170	560	264	100	180	244	266	305	446	446	171	213	660	265	713	470	115
065-040-200	-	3,45	-	-	100L	100	200	284	142	250	170	560	264	100	180	244	266	305	446	446	171	213	660	265	713	470	115
065-040-200	-	-	5,50	-	132S	100	230	284	142	300	190	603	314	132	180	263	285	350	465	491	207	274	703	285	809	550	115
065-040-200	-	-	7,50	-	132S	100	230	284	142	300	190	647	314	132	180	263	285	350	465	491	207	274	747	285	809	550	115
065-040-200	-	-	11,00	12,60	160M	100	280	284	142	350	220	766	372	160	180	291	313	423	493	564	241	325	866	385	987	720	115
065-040-200	-	-	-	17,30	160M	100	280	284	142	350	220	766	372	160	180	291	313	423	493	564	241	325	866	385	987	720	115
065-040-200	-	-	-	21,30	160L	100	280	284	142	350	220	802	372	160	180	291	313	423	493	564	263	325	902	385	987	720	115
065-040-250	1,10	-	-	-	90S	100	200	348	174	200	156	510	264	90	225	246	256	305	481	446	95	190	610	280	669	450	130
065-040-250	1,50	1,75	-	-	90L	100	200	348	174	200	156	510	264	90	225	246	256	305	481	446	107	190	610	280	669	450	130
065-040-250	2,20	2,55	-	-	100L	100	200	348	174	250	170	560	264	100	225	256	266	305	491	446	126	213	660	310	713	470	130
065-040-250	3,00	3,45	-	-	100L	100	200	348	174	250	170	560	264	100	225	256	266	305	491	446	126	213	660	310	713	470	130
065-040-250	-	4,55	-	-	112M	100	200	348	174	250	170	542	264	112	225	255	265	305	490	446	113	235	642	330	709	470	130
065-040-250	-	6,30	-	-	132S	100	230	348	174	300	193	650	314	132	225	275	285	350	510	491	150	274	750	345	812	550	130
065-040-250	-	-	7,50	-	132S	100	230	348	174	300	193	650	314	132	225	275	285	350	510	491	150	274	750	345	812	550	130
065-040-250	-	-	11,00	-	160M	100	280	348	174	350	226	772	372	160	225	291	313	423	538	564	247	325	872	385	993	720	130
065-040-250	-	-	15,00	-	160M	100	280	348	174	350	226	772	372	160	225	291	313	423	538	564	247	325	872	385	993	720	130
065-040-250	-	-	18,50	-	160L	100	280	348	174	350	226	808	372	160	225	291	313	423	538	564	269	325	908	385	993	720	130
065-040-250	-	-	22,00	-	180M	100	305	348	174	350	226	843	402	180	225	311	333	493	558	634	275	370	943	385	1005	740	130
065-040-250	-	-	30,00	-	200L	100	345	348	174	400	226	895	452	200	225	360	382	545	607	702	304	422	995	415	1144	830	130

Etachrom B 50, with levelling feet and motor shroud

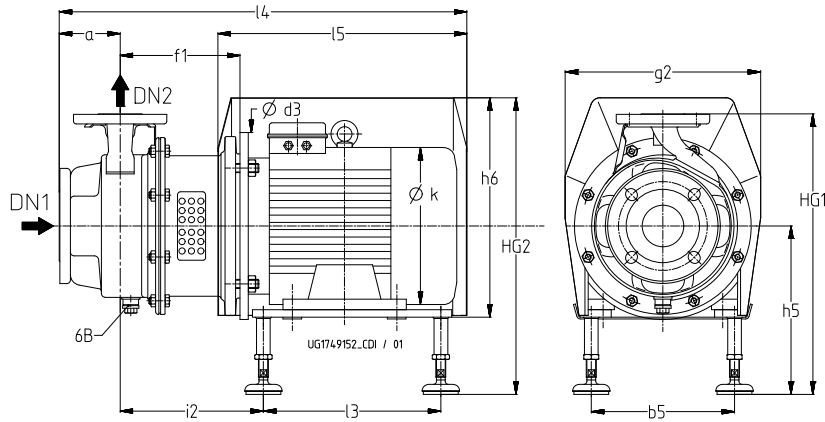

Etachrom B with levelling feet, with motor shroud

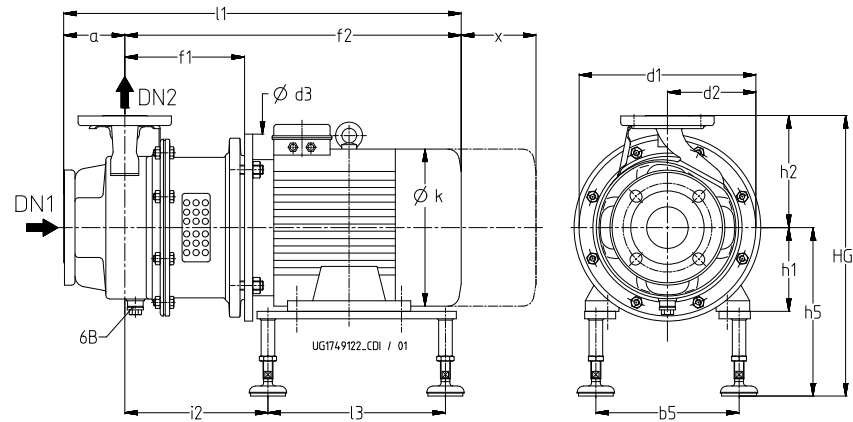

Etachrom B with levelling feet, without motor shroud

Table 29: Dimensions<sup>33)</sup>

Size	1450 rpm	1750 rpm	2900 rpm	3500 rpm	Motor	a	b <sub>5</sub>	d <sub>1</sub>	d <sub>2</sub>	d <sub>3</sub>	f <sub>1</sub>	f <sub>2</sub>	g <sub>2</sub>	h <sub>1</sub>	h <sub>2</sub>	h <sub>5</sub> min.	h <sub>5</sub> max.	h <sub>6</sub>	HG <sub>1</sub> max.	HG <sub>2</sub> max.	i <sub>2</sub>	k	l <sub>1</sub>	l <sub>3</sub>	l <sub>4</sub>	l <sub>5</sub>	x
	[kW]																										
065-050-125	0,55	-	-	-	80M	100	200	254	127	200	160	429	264	80	160	224	246	305	406	446	158	162	529	205	667	450	130
065-050-125	0,75	0,86	-	-	80M	100	200	254	127	200	160	461	264	80	160	224	246	305	406	446	158	162	561	205	667	450	130
065-050-125	1,10	1,27	-	-	90S	100	200	254	127	200	160	514	264	90	160	234	256	305	416	446	154	190	614	225	673	450	130
065-050-125	-	1,75	-	-	90L	100	200	254	127	200	160	514	264	90	160	234	256	305	416	446	166	190	614	225	673	450	130
065-050-125	-	-	3,00	-	100L	100	200	254	127	250	170	560	264	100	160	244	266	305	426	446	171	213	660	265	713	470	130
065-050-125	-	-	4,00	-	112M	100	200	254	127	250	170	542	264	112	160	243	265	305	425	446	178	235	642	265	709	470	130
065-050-125	-	-	5,50	6,30	132S	100	230	254	127	300	190	603	314	132	160	263	285	350	445	491	207	274	703	285	809	550	130
065-050-125	-	-	7,50	8,60	132S	100	230	254	127	300	190	647	314	132	160	263	285	350	445	491	207	274	747	285	809	550	130
065-050-125	-	-	-	12,60	160M	100	280	254	127	350	220	766	372	160	160	291	313	423	473	564	241	325	866	385	987	720	130
065-050-125	-	-	-	17,30	160M	100	280	254	127	350	220	766	372	160	160	291	313	423	473	564	241	325	866	385	987	720	130
065-050-125 F	0,75	0,86	-	-	80M	100	200	254	127	200	160	461	264	80	160	224	246	305	406	446	158	162	561	205	667	450	130
065-050-125 F	-	1,27	-	-	90S	100	200	254	127	200	160	514	264	90	160	234	256	305	416	446	154	190	614	225	673	450	130
065-050-125 F	-	-	2,20	-	90L	100	200	254	127	200	160	514	264	90	160	234	256	305	416	446	166	190	614	225	673	450	130
065-050-125 F	-	-	3,00	3,45	100L	100	200	254	127	250	170	560	264	100	160	244	266	305	426	446	171	213	660	265	713	470	130
065-050-125 F	-	-	4,00	4,55	112M	100	200	254	127	250	170	542	264	112	160	243	265	305	425	446	178	235	642	265	709	470	130

<sup>33)</sup> Tolerances of mating dimensions to EN 735

Size	1450 rpm	1750 rpm	2900 rpm	3500 rpm	Motor	a	b <sub>5</sub>	d <sub>1</sub>	d <sub>2</sub>	d <sub>3</sub>	f <sub>1</sub>	f <sub>2</sub>	g <sub>2</sub>	h <sub>1</sub>	h <sub>2</sub>	h <sub>5</sub> min.	h <sub>5</sub> max.	h <sub>6</sub>	HG <sub>1</sub> max.	HG <sub>2</sub> max.	i <sub>2</sub>	k	l <sub>1</sub>	l <sub>3</sub>	l <sub>4</sub>	l <sub>5</sub>	x
	[kW]					[mm]																					
065-050-125 F	-	-	5,50	6,30	132S	100	230	254	127	300	190	603	314	132	160	263	285	350	445	491	207	274	703	285	809	550	130
065-050-125 F	-	-	-	8,60	132S	100	230	254	127	300	190	647	314	132	160	263	285	350	445	491	207	274	747	285	809	550	130
065-050-160	0,75	-	-	-	80M	100	200	254	127	200	160	461	264	80	180	224	246	305	426	446	158	162	561	205	667	450	130
065-050-160	1,10	1,27	-	-	90S	100	200	254	127	200	160	514	264	90	180	234	256	305	436	446	154	190	614	225	673	450	130
065-050-160	1,50	1,75	-	-	90L	100	200	254	127	200	160	514	264	90	180	234	256	305	436	446	166	190	614	225	673	450	130
065-050-160	2,20	2,55	-	-	100L	100	200	254	127	250	170	560	264	100	180	244	266	305	446	446	171	213	660	265	713	470	130
065-050-160	-	3,45	-	-	100L	100	200	254	127	250	170	560	264	100	180	244	266	305	446	446	171	213	660	265	713	470	130
065-050-160	-	-	5,50	-	132S	100	230	254	127	300	190	603	314	132	180	263	285	350	465	491	207	274	703	285	809	550	130
065-050-160	-	-	7,50	-	132S	100	230	254	127	300	190	647	314	132	180	263	285	350	465	491	207	274	747	285	809	550	130
065-050-160	-	-	11,00	12,60	160M	100	280	254	127	350	220	766	372	160	180	291	313	423	493	564	241	325	866	385	987	720	130
065-050-160	-	-	15,00	17,30	160M	100	280	254	127	350	220	766	372	160	180	291	313	423	493	564	241	325	866	385	987	720	130
065-050-160	-	-	-	21,30	160L	100	280	254	127	350	220	802	372	160	180	291	313	423	493	564	263	325	902	385	987	720	130
065-050-200	0,75	-	-	-	80M	100	200	313	157	200	156	457	264	80	200	236	246	305	446	446	99	162	557	260	663	450	130
065-050-200	1,10	-	-	-	90S	100	200	313	157	200	156	510	264	90	200	246	256	305	456	446	95	190	610	280	669	450	130
065-050-200	1,50	1,75	-	-	90L	100	200	313	157	200	156	510	264	90	200	246	256	305	456	446	107	190	610	280	669	450	130
065-050-200	2,20	2,55	-	-	100L	100	200	313	157	250	170	560	264	100	200	256	266	305	466	446	126	213	660	310	713	470	130
065-050-200	3,00	3,45	-	-	100L	100	200	313	157	250	170	560	264	100	200	256	266	305	466	446	126	213	660	310	713	470	130
065-050-200	4,00	4,55	-	-	112M	100	200	313	157	250	170	542	264	112	200	255	265	305	465	446	113	235	642	330	709	470	130
065-050-200	-	6,30	-	-	132S	100	230	313	157	300	193	650	314	132	200	275	285	350	485	491	150	274	750	345	812	550	130
065-050-200	-	-	5,50	-	132S	100	230	313	157	300	193	606	314	132	200	275	285	350	485	491	150	274	706	345	812	550	130
065-050-200	-	-	7,50	-	132S	100	230	313	157	300	193	650	314	132	200	275	285	350	485	491	150	274	750	345	812	550	130
065-050-200	-	-	11,00	12,60	160M	100	280	313	157	350	226	772	372	160	200	291	313	423	513	564	247	325	872	385	993	720	130
065-050-200	-	-	15,00	17,30	160M	100	280	313	157	350	226	772	372	160	200	291	313	423	513	564	247	325	872	385	993	720	130
065-050-200	-	-	18,50	21,30	160L	100	280	313	157	350	226	808	372	160	200	291	313	423	513	564	269	325	908	385	993	720	130
065-050-200	-	-	22,00	24,50	180M	100	305	313	157	350	226	843	402	180	200	311	333	493	533	634	275	370	943	385	1005	740	130
065-050-200	-	-	-	33,50	200L	100	345	313	157	400	226	895	452	200	200	360	382	545	582	702	304	422	995	415	1144	830	130
065-050-200	-	-	-	41,50	200L	100	345	313	157	400	226	895	452	200	200	360	382	545	582	702	304	422	995	415	1144	830	130
065-050-250	1,50	-	-	-	90L	100	200	348	174	200	156	510	264	90	225	246	256	305	481	446	107	190	610	280	669	450	130
065-050-250	2,20	2,55	-	-	100L	100	200	348	174	250	170	560	264	100	225	256	266	305	491	446	126	213	660	310	713	450	130
065-050-250	3,00	3,45	-	-	100L	100	200	348	174	250	170	560	264	100	225	256	266	305	491	446	126	213	660	310	713	470	130
065-050-250	4,00	4,55	-	-	112M	100	200	348	174	250	170	542	264	112	225	255	265	305	490	446	113	235	642	330	709	470	130
065-050-250	-	6,30	-	-	132S	100	230	348	174	300	193	650	314	132	225	275	285	350	510	491	150	274	750	345	812	550	130
065-050-250	-	8,60	-	-	132M	100	230	348	174	300	193	650	314	132	225	275	285	350	510	491	169	298	750	345	812	550	130
065-050-250	-	12,60	-	-	160M	100	280	348	174	350	226	772	372	160	225	291	313	423	538	564	247	325	872	385	993	720	130
065-050-250	-	-	15,00	-	160M	100	280	348	174	350	226	772	372	160	225	291	313	423	538	564	247	325	872	385	993	720	130
065-050-250	-	-	18,50	-	160L	100	280	348	174	350	226	808	372	160	225	291	313	423	538	564	269	325	908	385	993	720	130

Size	1450 rpm	1750 rpm	2900 rpm	3500 rpm	Motor	a	b <sub>5</sub>	d <sub>1</sub>	d <sub>2</sub>	d <sub>3</sub>	f <sub>1</sub>	f <sub>2</sub>	g <sub>2</sub>	h <sub>1</sub>	h <sub>2</sub>	h <sub>5</sub> min.	h <sub>5</sub> max.	h <sub>6</sub>	HG <sub>1</sub> max.	HG <sub>2</sub> max.	i <sub>2</sub>	k	l <sub>1</sub>	l <sub>3</sub>	l <sub>4</sub>	l <sub>5</sub>	x
	[kW]					[mm]																					
065-050-250	-	-	22,00	-	180M	100	305	348	174	350	226	843	402	180	225	311	333	493	558	634	275	370	943	385	1005	740	130
065-050-250	-	-	30,00	-	200L	100	345	348	174	400	226	895	452	200	225	360	382	545	607	702	304	422	995	415	1144	830	130
065-050-250	-	-	37,00	-	200L	100	345	348	174	400	226	895	452	200	225	360	382	545	607	702	304	422	995	415	1144	830	130

## Etachrom B 65, with levelling feet and motor shroud

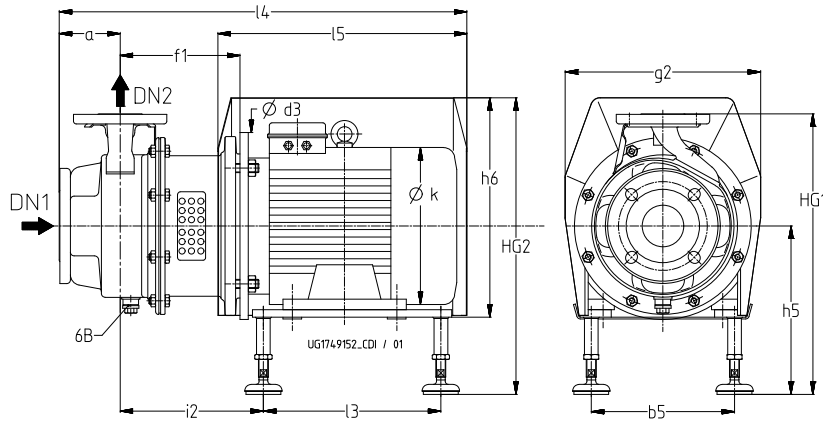

Etachrom B with levelling feet, with motor shroud

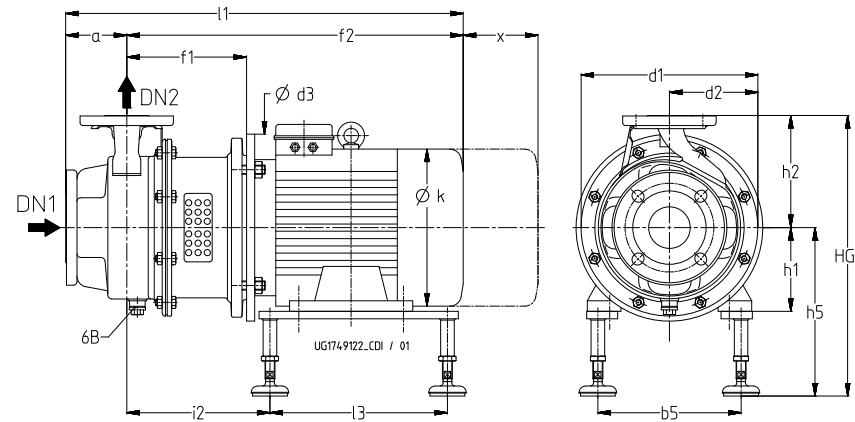

Etachrom B with levelling feet, without motor shroud

Table 30: Dimensions<sup>34)</sup>

Size	1450 rpm	1750 rpm	2900 rpm	3500 rpm	Motor	a	b <sub>5</sub>	d <sub>1</sub>	d <sub>2</sub>	d <sub>3</sub>	f <sub>1</sub>	f <sub>2</sub>	g <sub>2</sub>	h <sub>1</sub>	h <sub>2</sub>	h <sub>5</sub> min.	h <sub>5</sub> max.	h <sub>6</sub>	HG <sub>1</sub> max.	HG <sub>2</sub> max.	i <sub>2</sub>	k	l <sub>1</sub>	l <sub>3</sub>	l <sub>4</sub>	l <sub>5</sub>	x
	[kW]					[mm]																					
080-065-200	1,50	-	-	-	90L	100	200	348	174	200	156	510	264	90	225	246	256	305	481	446	107	190	610	280	669	450	130
080-065-200	2,20	2,55	-	-	100L	100	200	348	174	250	170	560	264	100	225	256	266	305	491	446	126	213	660	310	713	470	130
080-065-200	3,00	3,45	-	-	100L	100	200	348	174	250	170	560	264	100	225	256	266	305	491	446	126	213	660	310	713	470	130
080-065-200	4,00	4,55	-	-	112M	100	200	348	174	250	170	542	264	112	225	255	265	305	490	446	113	235	642	330	709	470	130
080-065-200	-	6,30	-	-	132S	100	230	348	174	300	193	650	314	132	225	275	285	350	510	491	150	274	750	345	812	550	130
080-065-200	-	8,60	-	-	132M	100	230	348	174	300	193	650	314	132	225	275	285	350	510	491	169	298	750	345	812	550	130
080-065-200	-	-	11,00	-	160M	100	280	348	174	350	226	772	372	160	225	291	313	423	538	564	247	325	872	385	993	720	130
080-065-200	-	-	15,00	-	160M	100	280	348	174	350	226	772	372	160	225	291	313	423	538	564	247	325	872	385	993	720	130
080-065-200	-	-	18,50	21,30	160L	100	280	348	174	350	226	808	372	160	225	291	313	423	538	564	269	325	908	385	993	720	130
080-065-200	-	-	22,00	24,50	180M	100	305	348	174	350	226	843	402	180	225	311	333	493	558	634	275	370	943	385	1005	740	130
080-065-200	-	-	30,00	33,50	200L	100	345	348	174	400	226	895	452	200	225	360	382	545	607	702	304	422	995	415	1144	830	130
080-065-200	-	-	37,00	41,50	200L	100	345	348	174	400	226	895	452	200	225	360	382	545	607	702	304	422	995	415	1144	830	130
080-065-250	2,20	-	-	-	100L	100	200	348	174	250	190	580	264	100	250	256	266	305	516	446	146	213	680	310	733	470	140
080-065-250	3,00	-	-	-	100L	100	200	348	174	250	190	580	264	100	250	256	266	305	516	446	146	213	680	310	733	470	140
080-065-250	4,00	4,55	-	-	112M	100	200	348	174	250	190	562	264	112	250	255	265	305	515	446	133	235	662	330	729	470	140

<sup>34)</sup> Tolerances of mating dimensions to EN 735

Size	1450 rpm	1750 rpm	2900 rpm	3500 rpm	Motor	a	b <sub>5</sub>	d <sub>1</sub>	d <sub>2</sub>	d <sub>3</sub>	f <sub>1</sub>	f <sub>2</sub>	g <sub>2</sub>	h <sub>1</sub>	h <sub>2</sub>	h <sub>5</sub> min.	h <sub>5</sub> max.	h <sub>6</sub>	HG <sub>1</sub> max.	HG <sub>2</sub> max.	i <sub>2</sub>	k	l <sub>1</sub>	l <sub>3</sub>	l <sub>4</sub>	l <sub>5</sub>	x
	[kW]					[mm]																					
080-065-250	5,50	6,30	-	-	132S	100	230	348	174	300	213	670	314	132	250	275	285	350	535	491	170	274	770	345	832	550	140
080-065-250	7,50	8,60	-	-	132M	100	230	348	174	300	213	670	314	132	250	275	285	350	535	491	189	298	770	345	832	550	140
080-065-250	-	12,60	-	-	160M	100	280	348	174	350	246	792	372	160	250	291	313	423	563	564	267	325	892	385	1013	720	140
080-065-250	-	-	15,00	-	160M	100	280	348	174	350	246	792	372	160	250	291	313	423	563	564	267	325	892	385	1013	720	150
080-065-250	-	-	18,50	-	160L	100	280	348	174	350	246	828	372	160	250	291	313	423	563	564	289	325	928	385	1013	720	150
080-065-250	-	-	22,00	-	180M	100	305	348	174	350	246	863	402	180	250	311	333	493	583	634	295	370	963	385	1025	740	150
080-065-250	-	-	30,00	-	200L	100	345	348	174	400	246	915	452	200	250	360	382	545	632	702	324	422	1015	415	1164	830	150
080-065-250	-	-	37,00	-	200L	100	345	348	174	400	246	915	452	200	250	360	382	545	632	702	324	422	1015	415	1164	830	150
080-065-250	-	-	45,00	-	225M	100	390	348	174	450	277	1032	527	225	250	385	407	616	657	773	354	468	1132	455	1331	950	150



## Etachrom B 80, with levelling feet and motor shroud

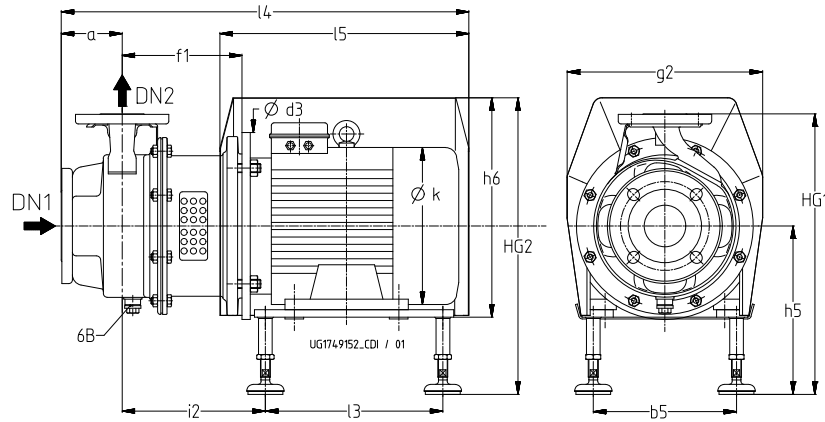

Etachrom B with levelling feet, with motor shroud

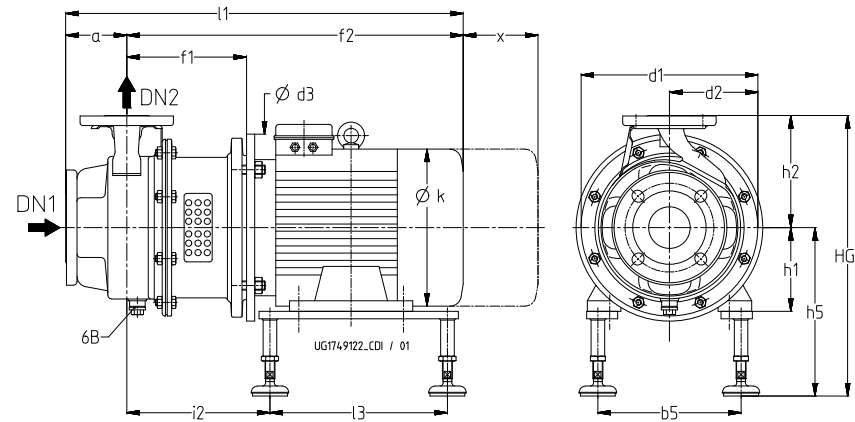

Etachrom B with levelling feet, without motor shroud

Table 31: Dimensions<sup>35)</sup>

Size	1450 rpm	1750 rpm	2900 rpm	3500 rpm	Motor	a	b <sub>5</sub>	d <sub>1</sub>	d <sub>2</sub>	d <sub>3</sub>	f <sub>1</sub>	f <sub>2</sub>	g <sub>2</sub>	h <sub>1</sub>	h <sub>2</sub>	h <sub>5</sub> min.	h <sub>5</sub> max.	h <sub>6</sub>	HG <sub>1</sub> max.	HG <sub>2</sub> max.	i <sub>2</sub>	k	l <sub>1</sub>	l <sub>3</sub>	l <sub>4</sub>	l <sub>5</sub>	x
	[kW]					[mm]																					
100-080-200	2,20	-	-	-	100L	125	200	348	174	250	190	580	264	100	250	256	266	305	516	446	146	213	705	310	758	470	150
100-080-200	3,00	3,45	-	-	100L	125	200	348	174	250	190	580	264	100	250	256	266	305	516	446	146	213	705	310	758	470	150
100-080-200	4,00	4,55	-	-	112M	125	200	348	174	250	190	562	264	112	250	255	265	305	515	446	133	235	687	330	754	470	150
100-080-200	5,50	6,30	-	-	132S	125	230	348	174	300	213	670	314	132	250	275	285	350	535	491	170	274	795	345	857	550	150
100-080-200	7,50	8,60	-	-	132M	125	230	348	174	300	213	670	314	132	250	275	285	350	535	491	189	298	795	345	857	550	150
100-080-200	-	12,60	-	-	160M	125	280	348	174	350	246	792	372	160	250	291	313	423	563	564	267	325	917	385	1038	720	150
100-080-200	-	-	15,00	-	160M	125	280	348	174	350	246	792	372	160	250	291	313	423	563	564	267	325	917	385	1038	720	150
100-080-200	-	-	18,50	-	160L	125	280	348	174	350	246	828	372	160	250	291	313	423	563	564	289	325	953	385	1038	720	150
100-080-200	-	-	22,00	-	180M	125	305	348	174	350	246	863	402	180	250	311	333	493	583	634	295	370	988	385	1050	740	150
100-080-200	-	-	30,00	-	200L	125	345	348	174	400	246	915	452	200	250	360	382	545	632	702	324	422	1040	415	1189	830	150
100-080-200	-	-	37,00	-	200L	125	345	348	174	400	246	915	452	200	250	360	382	545	632	702	324	422	1040	415	1189	830	150
100-080-200	-	-	45,00	-	225M	125	390	348	174	450	277	1032	527	225	250	385	407	616	657	773	354	468	1157	455	1356	950	150
100-080-250	3,00	-	-	-	100L	125	200	348	174	250	190	580	264	100	280	256	266	305	546	446	146	213	705	310	758	470	150
100-080-250	4,00	-	-	-	112M	125	200	348	174	250	190	562	264	112	280	255	265	305	545	446	133	235	687	330	754	470	150
100-080-250	5,50	6,30	-	-	132S	125	230	348	174	300	213	670	314	132	280	275	285	350	565	491	170	274	795	345	857	550	150

<sup>35)</sup> Tolerances of mating dimensions to EN 735



Size	1450 rpm	1750 rpm	2900 rpm	3500 rpm	Motor	a	b <sub>5</sub>	d <sub>1</sub>	d <sub>2</sub>	d <sub>3</sub>	f <sub>1</sub>	f <sub>2</sub>	g <sub>2</sub>	h <sub>1</sub>	h <sub>2</sub>	h <sub>5</sub> min.	h <sub>5</sub> max.	h <sub>6</sub>	HG <sub>1</sub> max.	HG <sub>2</sub> max.	i <sub>2</sub>	k	l <sub>1</sub>	l <sub>3</sub>	l <sub>4</sub>	l <sub>5</sub>	x
	[kW]					[mm]																					
100-080-250	7,50	8,60	-	-	132M	125	230	348	174	300	213	670	314	132	280	275	285	350	565	491	189	298	795	345	857	550	150
100-080-250	11,00	12,60	-	-	160M	125	280	348	174	350	246	792	372	160	280	291	313	423	593	564	267	325	917	385	1038	720	150
100-080-250	15,00	17,30	-	-	160L	125	280	348	174	350	246	828	372	160	280	291	313	423	593	564	289	325	953	385	1038	720	150
100-080-250	-	21,30	-	-	180M	125	305	348	174	350	246	863	402	180	280	311	333	493	613	634	295	370	988	385	1050	740	150

Etachrom B 25, from motor 132 (5.50 kW), with motor foot

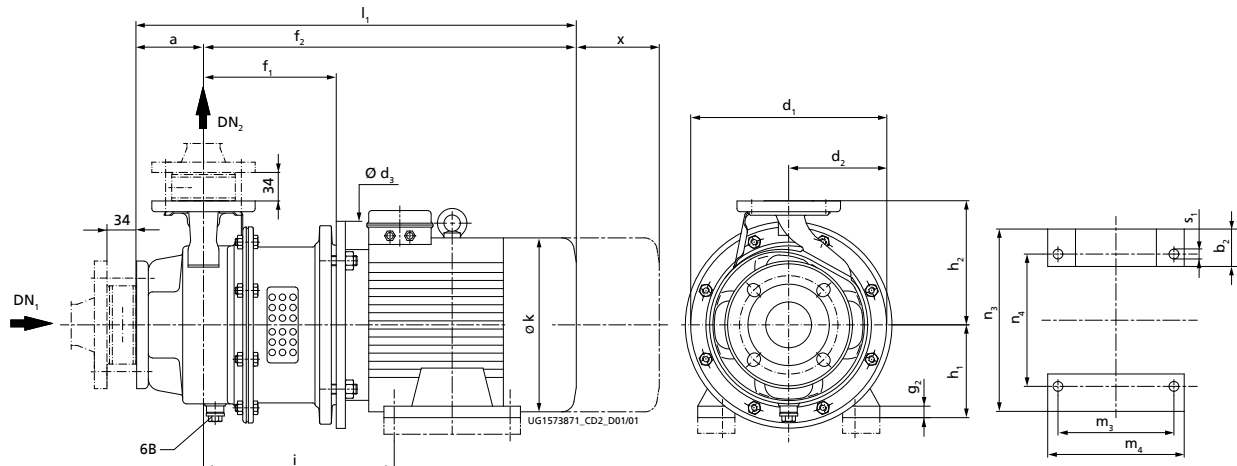

Fig. 10: Etachrom B with motor foot, dimensions [mm]

6B	Fluid drain	G <sup>3/8</sup> = ISO 228/1
----	-------------	------------------------------

DN = EN 1092-1/DN.../PN 16/B

Table 32: Dimensions

Size	1450 rpm	1750 rpm	2900 rpm	3500 rpm	a	b <sub>2</sub>	d <sub>1</sub>	d <sub>2</sub>	d <sub>3</sub>	f <sub>1</sub>	f <sub>2</sub>	g <sub>2</sub>	h <sub>1</sub>	h <sub>2</sub>	i	k	l <sub>1</sub>	m <sub>3</sub>	m <sub>4</sub>	n <sub>3</sub>	n <sub>4</sub>	s <sub>1</sub>	x
	[kW]				[mm] <sup>36)</sup>																		
050-025-160 <sup>37)</sup>	-	-	-	6,30	80	55	254	127	300	188	601	15	132	160	277	274	681	140	220	270	216	12	115
050-025-160 <sup>37)</sup>	-	-	-	8,60	80	55	254	127	300	188	645	15	132	160	277	274	725	140	220	270	216	12	115
050-025-200 <sup>37)</sup>	-	-	5,50	6,30	80	55	284	142	300	188	601	15	132	180	277	274	681	140	220	270	216	12	115
050-025-200 <sup>37)</sup>	-	-	7,50	8,60	80	55	284	142	300	188	645	15	132	180	277	274	725	140	220	270	216	12	115
050-025-200 <sup>37)</sup>	-	-	-	12,60	80	70	284	142	350	218	764	21	160	180	326	325	844	210	310	323	254	15	115
050-025-200 <sup>37)</sup>	-	-	-	17,30	80	70	284	142	350	218	764	21	160	180	326	325	844	210	310	323	254	15	115
050-025-250 <sup>38)</sup>	-	-	5,50	-	100	55	348	174	300	193	606	15	132	225	282	274	706	140	220	270	216	12	130
050-025-250 <sup>38)</sup>	-	-	7,50	-	100	55	348	174	300	193	650	15	132	225	282	274	750	140	220	270	216	12	130
050-025-250 <sup>37)</sup>	-	-	11,00	-	100	70	348	174	350	226	772	21	160	225	334	325	872	210	310	323	254	15	130
050-025-250 <sup>37)</sup>	-	-	15,00	-	100	70	348	174	350	226	772	21	160	225	334	325	872	210	310	323	254	15	130

<sup>36)</sup> Tolerances of mating dimensions to EN 735

<sup>37)</sup> On this size, the motor feet must be shimmed (20 mm).

<sup>38)</sup> On this size, the motor feet must be shimmed (45 mm).

Etachrom B 32, from motor 132 (5.50 kW), with motor foot

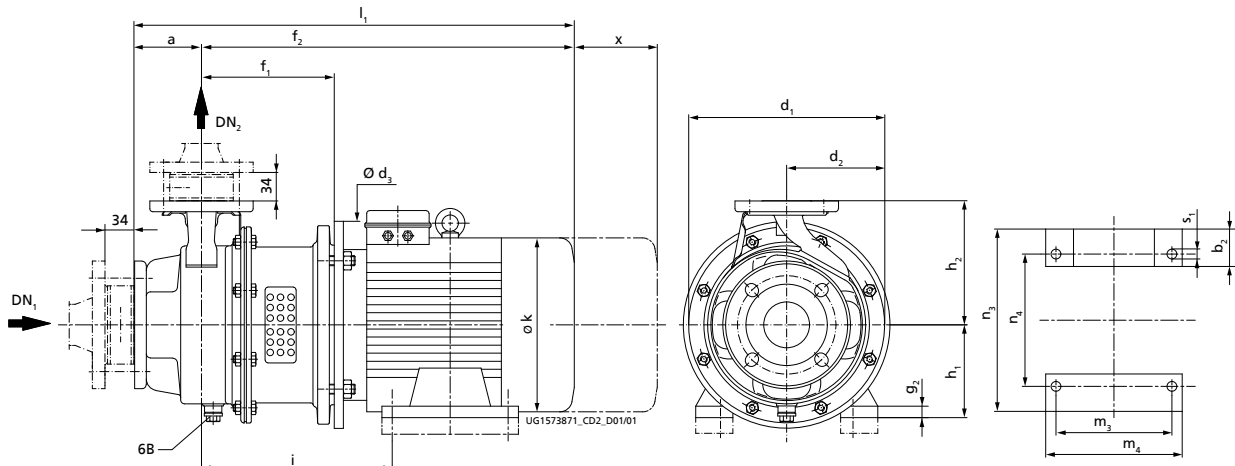

Fig. 11: Etachrom B with motor foot, dimensions [mm]

6B	Fluid drain	G <sup>3/8</sup> = ISO 228/1
----	-------------	------------------------------

DN = EN 1092-1/DN.../PN 16/B

Table 33: Dimensions

Size	1450 rpm	1750 rpm	2900 rpm	3500 rpm	a	b <sub>2</sub>	d <sub>1</sub>	d <sub>2</sub>	d <sub>3</sub>	f <sub>1</sub>	f <sub>2</sub>	g <sub>2</sub>	h <sub>1</sub>	h <sub>2</sub>	i	k	l <sub>1</sub>	m <sub>3</sub>	m <sub>4</sub>	n <sub>3</sub>	n <sub>4</sub>	s <sub>1</sub>	x
	[kW]				[mm] <sup>39)</sup>																		
050-032-160 <sup>40)</sup>	-	-	5,50	6,30	80	55	254	127	300	188	601	15	132	160	277	274	681	140	220	270	216	12	115
050-032-160 <sup>40)</sup>	-	-	-	8,60	80	55	254	127	300	188	645	15	132	160	277	274	725	140	220	270	216	12	115
050-032-160 <sup>40)</sup>	-	-	-	12,60	80	70	254	127	350	218	764	21	160	160	326	325	844	210	310	323	254	15	115
050-032-200 <sup>40)</sup>	-	-	5,50	6,30	80	55	284	142	300	188	601	15	132	180	277	274	681	140	220	270	216	12	115
050-032-200 <sup>40)</sup>	-	-	7,50	8,60	80	55	284	142	300	188	645	15	132	180	277	274	725	140	220	270	216	12	115
050-032-200 <sup>40)</sup>	-	-	11,00	12,60	80	70	284	142	350	218	764	21	160	180	326	325	844	210	310	323	254	15	115
050-032-200 <sup>40)</sup>	-	-	-	17,30	80	70	284	142	350	218	764	21	160	180	326	325	844	210	310	323	254	15	115
050-032-250 <sup>41)</sup>	-	6,30	-	-	100	55	348	174	300	193	650	15	132	225	282	274	750	140	220	270	216	12	130
050-032-250 <sup>41)</sup>	-	-	5,50	-	100	55	348	174	300	193	606	15	132	225	282	274	706	140	220	270	216	12	130
050-032-250 <sup>41)</sup>	-	-	7,50	-	100	55	348	174	300	193	650	15	132	225	282	274	750	140	220	270	216	12	130
050-032-250 <sup>40)</sup>	-	-	11,00	-	100	70	348	174	350	226	772	21	160	225	334	325	872	210	310	300	254	15	130
050-032-250 <sup>40)</sup>	-	-	15,00	-	100	70	348	174	350	226	772	21	160	225	334	325	872	210	310	323	254	15	130
050-032-250 <sup>40)</sup>	-	-	18,50	-	100	70	348	174	350	226	808	21	160	225	334	325	908	254	314	323	254	15	130

<sup>39)</sup> Tolerances of mating dimensions to EN 735

<sup>40)</sup> On this size, the motor feet must be shimmed (20 mm).

<sup>41)</sup> On this size, the motor feet must be shimmed (45 mm).

Etachrom B 40, from motor 132 (5.50 kW), with motor foot

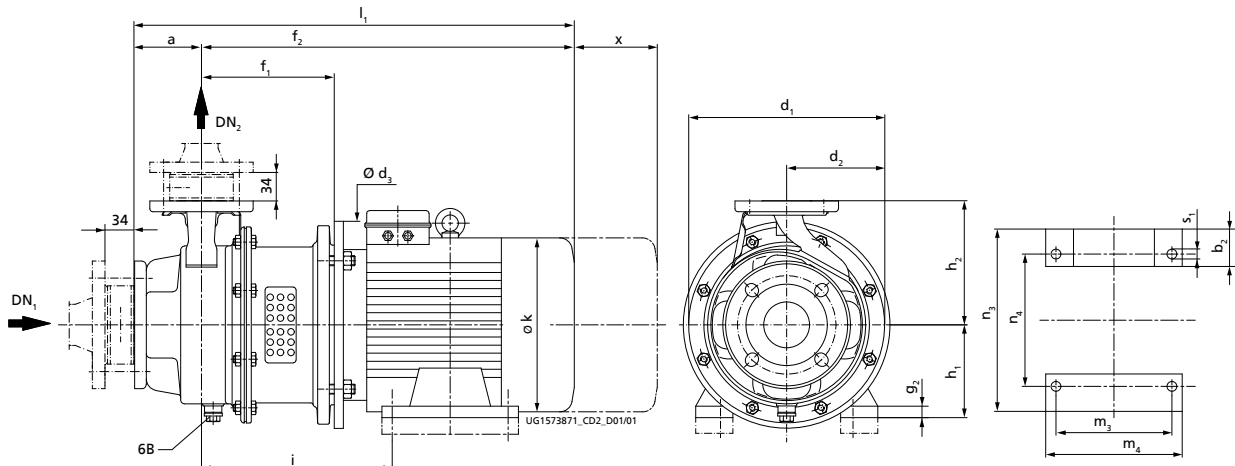

Fig. 12: Etachrom B with motor foot, dimensions [mm]

6B	Fluid drain	G <sup>3/8</sup> = ISO 228/1
----	-------------	------------------------------

DN = EN 1092-1/DN.../PN 16/B

Table 34: Dimensions

Size	1450 rpm	1750 rpm	2900 rpm	3500 rpm	a	b <sub>2</sub>	d <sub>1</sub>	d <sub>2</sub>	d <sub>3</sub>	f <sub>1</sub>	f <sub>2</sub>	g <sub>2</sub>	h <sub>1</sub>	h <sub>2</sub>	i	k	l <sub>1</sub>	m <sub>3</sub>	m <sub>4</sub>	n <sub>3</sub>	n <sub>4</sub>	s <sub>1</sub>	x
	[kW]				[mm] <sup>42)</sup>																		
065-040-160 <sup>43)</sup>	-	-	5,50	6,30	80	55	254	127	300	190	603	15	132	160	279	274	683	140	220	270	216	12	115
065-040-160 <sup>43)</sup>	-	-	7,50	8,60	80	55	254	127	300	190	647	15	132	160	279	274	727	140	220	270	216	12	115
065-040-160 <sup>43)</sup>	-	-	11,00	12,60	80	70	254	127	350	220	766	21	160	160	328	325	846	210	310	323	254	15	115
065-040-160 <sup>43)</sup>	-	-	-	17,30	80	70	254	127	350	220	766	21	160	160	328	325	846	210	310	323	254	15	115
065-040-200 <sup>43)</sup>	-	-	5,50	-	100	55	284	142	300	190	603	15	132	180	279	274	703	140	220	270	216	12	115
065-040-200 <sup>43)</sup>	-	-	7,50	-	100	55	284	142	300	190	647	15	132	180	279	274	747	140	220	270	216	12	115
065-040-200 <sup>43)</sup>	-	-	11,00	12,60	100	70	284	142	350	220	766	21	160	180	328	325	866	210	310	323	254	15	115
065-040-200 <sup>43)</sup>	-	-	-	17,30	100	70	284	142	350	220	766	21	160	180	328	325	866	210	310	323	254	15	115
065-040-200 <sup>43)</sup>	-	-	-	21,30	100	70	284	142	350	220	802	21	160	180	328	325	902	254	314	323	254	15	115
065-040-250 <sup>44)</sup>	-	6,30	-	-	100	55	348	174	300	193	650	15	132	225	282	274	750	140	220	270	216	12	130
065-040-250 <sup>44)</sup>	-	-	7,50	-	100	55	348	174	300	193	650	15	132	225	282	274	750	140	220	270	216	12	130
065-040-250 <sup>43)</sup>	-	-	11,00	-	100	70	348	174	350	226	772	21	160	225	334	325	872	210	310	323	254	15	130
065-040-250 <sup>43)</sup>	-	-	15,00	-	100	70	348	174	350	226	772	21	160	225	334	325	872	210	310	323	254	15	130
065-040-250 <sup>43)</sup>	-	-	18,50	-	100	70	348	174	350	226	808	21	160	225	334	325	908	254	314	323	254	15	130
065-040-250	-	-	22,00	-	100	80	348	174	350	226	843	23	180	225	347	370	943	241	343	368	279	15	130
065-040-250 <sup>43)</sup>	-	-	30,00	-	100	85	348	174	400	226	895	30	200	225	359	422	995	305	388	404	318	19	130

<sup>42</sup> Tolerances of mating dimensions to EN 735

<sup>43</sup> On this size, the motor feet must be shimmed (20 mm).

<sup>44</sup> On this size, the motor feet must be shimmed (45 mm).

Etachrom B 50, from motor 132 (5.50 kW), with motor foot

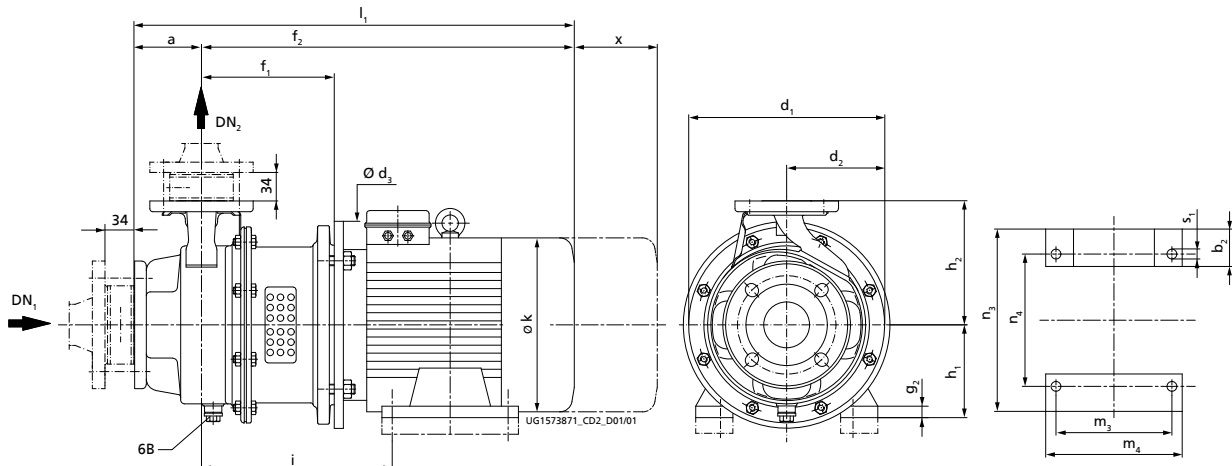

Fig. 13: Etachrom B with motor foot, dimensions [mm]

6B	Fluid drain	G <sup>3/8</sup> = ISO 228/1
----	-------------	------------------------------

DN = EN 1092-1/DN.../PN 16/B

Table 35: Dimensions

Size	1450 rpm	1750 rpm	2900 rpm	3500 rpm	a	b <sub>2</sub>	d <sub>1</sub>	d <sub>2</sub>	d <sub>3</sub>	f <sub>1</sub>	f <sub>2</sub>	g <sub>2</sub>	h <sub>1</sub>	h <sub>2</sub>	i	k	l <sub>1</sub>	m <sub>3</sub>	m <sub>4</sub>	n <sub>3</sub>	n <sub>4</sub>	s <sub>1</sub>	x
	[kW]				[mm] <sup>45)</sup>																		
065-050-125 <sup>46)</sup>	-	-	5,50	6,30	100	55	254	127	300	190	603	15	132	160	279	274	703	140	220	270	216	12	130
065-050-125 <sup>46)</sup>	-	-	7,50	8,60	100	55	254	127	300	190	647	15	132	160	279	274	747	140	220	270	216	12	130
065-050-125 <sup>46)</sup>	-	-	-	12,60	100	70	254	127	350	220	766	21	160	160	328	325	866	210	310	323	254	15	130
065-050-125 <sup>46)</sup>	-	-	-	17,30	100	70	254	127	350	220	766	21	160	160	328	325	866	210	310	323	254	15	130
065-050-160 <sup>46)</sup>	-	-	5,50	-	100	55	254	127	300	190	603	15	132	180	279	274	703	140	220	270	216	12	130
065-050-160 <sup>46)</sup>	-	-	7,50	-	100	55	254	127	300	190	647	15	132	180	279	274	747	140	220	270	216	12	130
065-050-160 <sup>46)</sup>	-	-	11,00	12,60	100	70	254	127	350	220	766	21	160	180	328	325	866	210	310	323	254	15	130
065-050-160 <sup>46)</sup>	-	-	15,00	17,30	100	70	254	127	350	220	766	21	160	180	328	325	866	210	310	323	254	15	130
065-050-160 <sup>46)</sup>	-	-	-	21,30	100	70	254	127	350	220	802	21	160	180	328	325	902	254	314	323	254	15	130
065-050-200 <sup>47)</sup>	-	6,30	-	-	100	55	313	157	300	193	650	15	132	200	282	274	750	140	220	270	216	12	130
065-050-200 <sup>47)</sup>	-	-	5,50	-	100	55	313	157	300	193	606	15	132	200	282	274	706	140	220	270	216	12	130
065-050-200 <sup>47)</sup>	-	-	7,50	-	100	55	313	157	300	193	650	15	132	200	282	274	750	140	220	270	216	12	130
065-050-200 <sup>46)</sup>	-	-	11,00	12,60	100	70	313	157	350	226	772	21	160	200	334	325	872	210	310	323	254	15	130
065-050-200 <sup>46)</sup>	-	-	15,00	17,30	100	70	313	157	350	226	772	21	160	200	334	325	872	210	310	323	254	15	130
065-050-200 <sup>46)</sup>	-	-	18,50	21,30	100	70	313	157	350	226	808	21	160	200	334	325	908	254	314	323	254	15	130
065-050-200 <sup>46)</sup>	-	-	22,00	24,50	100	80	313	157	350	226	843	23	180	200	347	370	943	241	343	368	279	15	130
065-050-200 <sup>46)</sup>	-	-	-	33,50	100	85	313	157	400	226	895	30	200	200	359	422	995	305	388	404	318	19	130
065-050-200 <sup>46)</sup>	-	-	-	41,50	100	85	313	157	400	226	895	30	200	200	359	422	995	305	388	404	318	19	130
065-050-250 <sup>47)</sup>	-	6,30	-	-	100	55	348	174	300	193	650	15	132	225	282	274	750	140	220	270	216	12	130
065-050-250 <sup>47)</sup>	-	8,60	-	-	100	59	348	174	300	193	650	15	132	225	282	298	750	178	240	270	216	12	130
065-050-250 <sup>46)</sup>	-	12,60	-	-	100	70	348	174	350	226	772	21	160	225	334	325	872	210	310	323	254	15	130
065-050-250 <sup>46)</sup>	-	-	15,00	-	100	70	348	174	350	226	772	21	160	225	334	325	872	210	310	323	254	15	130
065-050-250 <sup>46)</sup>	-	-	18,50	-	100	70	348	174	350	226	808	21	160	225	334	325	908	254	314	323	254	15	130
065-050-250 <sup>46)</sup>	-	-	22,00	-	100	80	348	174	350	226	843	23	180	225	347	370	943	241	343	368	279	15	130
065-050-250 <sup>46)</sup>	-	-	30,00	-	100	85	348	174	400	226	895	30	200	225	359	422	995	305	388	404	318	19	130
065-050-250 <sup>46)</sup>	-	-	37,00	-	100	85	348	174	400	226	895	30	200	225	359	422	995	305	388	404	318	19	130

<sup>45</sup> Tolerances of mating dimensions to EN 735

<sup>46</sup> On this size, the motor feet must be shimmed (20 mm).

<sup>47</sup> On this size, the motor feet must be shimmed (45 mm).

Etachrom B 65, from motor 132 (5.50 kW), with motor foot

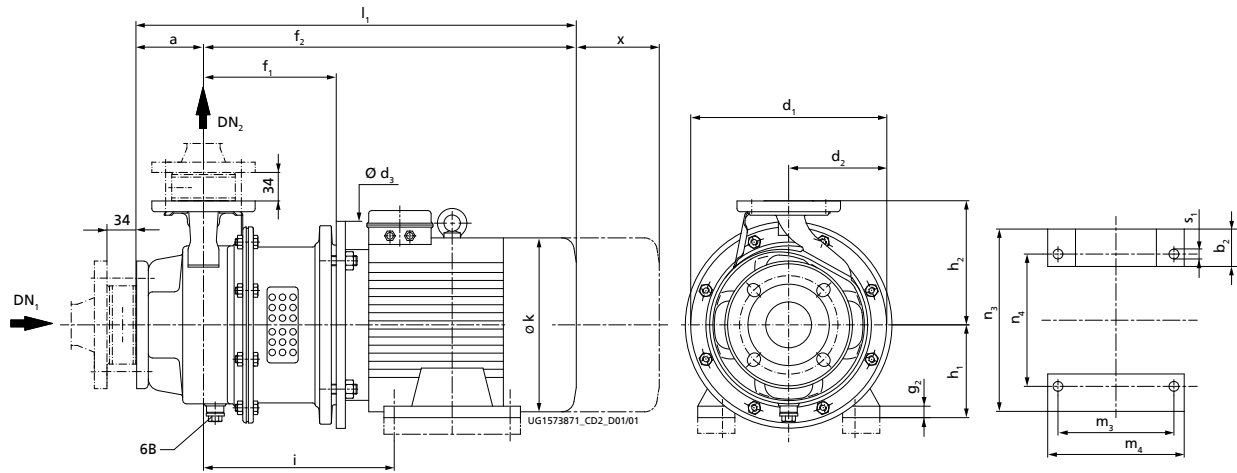

Fig. 14: Etachrom B with motor foot, dimensions [mm]

6B	Fluid drain	G <sup>3/8</sup> = ISO 228/1
----	-------------	------------------------------

DN = EN 1092-1/DN.../PN 16/B

Table 36: Dimensions

Size	1450 rpm	1750 rpm	2900 rpm	3500 rpm	a	b <sub>2</sub>	d <sub>1</sub>	d <sub>2</sub>	d <sub>3</sub>	f <sub>1</sub>	f <sub>2</sub>	g <sub>2</sub>	h <sub>1</sub>	h <sub>2</sub>	i	k	l <sub>1</sub>	m <sub>3</sub>	m <sub>4</sub>	n <sub>3</sub>	n <sub>4</sub>	s <sub>1</sub>	x
	[kW]				[mm] <sup>48)</sup>																		
080-065-200 <sup>49)</sup>	-	6,30	-	-	100	55	348	174	300	193	650	15	132	225	282	274	750	140	220	270	216	12	130
080-065-200 <sup>49)</sup>	-	8,60	-	-	100	59	348	174	300	193	650	15	132	225	282	298	750	178	240	270	216	12	130
080-065-200 <sup>50)</sup>	-	-	11,00	-	100	70	348	174	350	226	772	21	160	225	334	325	872	210	310	323	254	15	130
080-065-200 <sup>50)</sup>	-	-	15,00	-	100	70	348	174	350	226	772	21	160	225	334	325	872	210	310	323	254	15	130
080-065-200 <sup>50)</sup>	-	-	18,50	21,30	100	70	348	174	350	226	808	21	160	225	334	325	908	254	314	323	254	15	130
080-065-200 <sup>50)</sup>	-	-	22,00	24,50	100	80	348	174	350	226	843	23	180	225	347	370	943	241	343	368	279	15	130
080-065-200 <sup>50)</sup>	-	-	30,00	33,50	100	85	348	174	400	226	895	30	200	225	359	422	995	305	388	404	318	19	130
080-065-200 <sup>50)</sup>	-	-	37,00	41,50	100	85	348	174	400	226	895	30	200	225	359	422	995	305	388	404	318	19	130
080-065-250 <sup>49)</sup>	5,50	6,30	-	-	100	55	348	174	300	213	670	15	132	250	302	274	770	140	220	270	216	12	140
080-065-250 <sup>49)</sup>	7,50	8,60	-	-	100	59	348	174	300	213	670	15	132	250	302	298	770	178	240	270	216	12	140
080-065-250 <sup>50)</sup>	-	12,60	-	-	100	70	348	174	350	246	792	21	160	250	354	325	892	210	310	323	254	15	140
080-065-250 <sup>50)</sup>	-	-	15,00	-	100	70	348	174	350	246	792	21	160	250	354	325	892	210	310	323	254	15	150
080-065-250 <sup>50)</sup>	-	-	18,50	-	100	70	348	174	350	246	828	21	160	250	354	325	928	254	314	323	254	15	150
080-065-250 <sup>50)</sup>	-	-	22,00	-	100	80	348	174	350	246	863	23	180	250	367	370	963	241	343	368	279	15	150
080-065-250 <sup>50)</sup>	-	-	30,00	-	100	85	348	174	400	246	915	30	200	250	379	422	1015	305	388	404	318	19	150
080-065-250 <sup>50)</sup>	-	-	37,00	-	100	85	348	174	400	246	915	30	200	250	379	422	1015	305	388	404	318	19	150
080-065-250 <sup>50)</sup>	-	-	45,00	-	100	100	348	174	450	277	1032	35	225	250	426	468	1132	311	412	458	356	19	150

<sup>48)</sup> Tolerances of mating dimensions to EN 735

<sup>49)</sup> On this size, the motor feet must be shimmed (45 mm).

<sup>50)</sup> On this size, the motor feet must be shimmed (20 mm).

Etachrom B 80, from motor 132 (5.50 kW), with motor foot

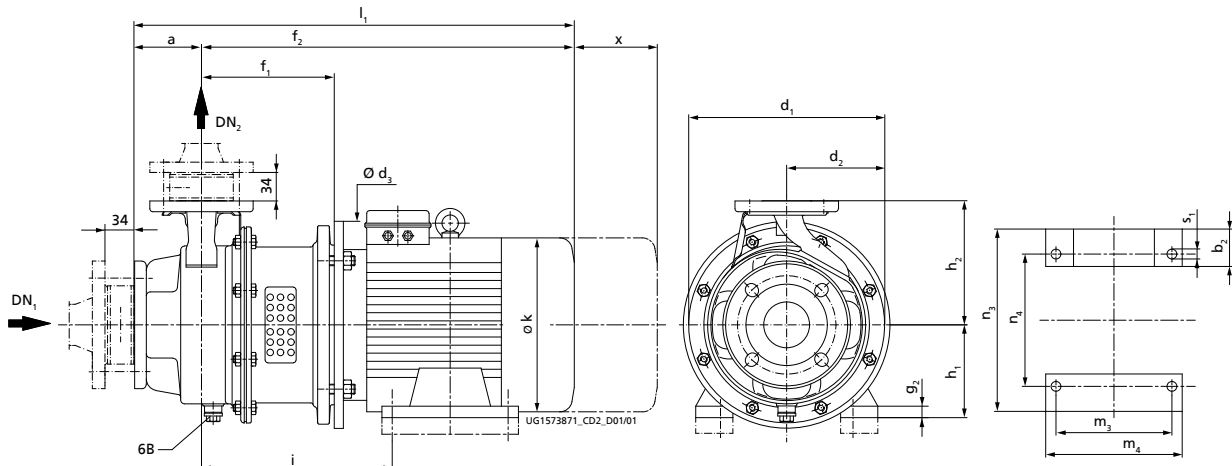

Fig. 15: Etachrom B with motor foot, dimensions [mm]

6B	Fluid drain	G <sup>3/8</sup> = ISO 228/1
----	-------------	------------------------------

DN = EN 1092-1/DN.../PN 16/B

Table 37: Dimensions

Size	1450 rpm	1750 rpm	2900 rpm	3500 rpm	a	b <sub>2</sub>	d <sub>1</sub>	d <sub>2</sub>	d <sub>3</sub>	f <sub>1</sub>	f <sub>2</sub>	g <sub>2</sub>	h <sub>1</sub>	h <sub>2</sub>	i	k	l <sub>1</sub>	m <sub>3</sub>	m <sub>4</sub>	n <sub>3</sub>	n <sub>4</sub>	s <sub>1</sub>	x
	[kW]				[mm] <sup>51)</sup>																		
100-080-200 <sup>52)</sup>	5,50	6,30	-	-	125	55	348	174	300	213	670	15	132	250	302	274	795	140	220	270	216	12	150
100-080-200 <sup>52)</sup>	7,50	8,60	-	-	125	59	348	174	300	213	670	15	132	250	302	298	795	178	240	270	216	12	150
100-080-200 <sup>53)</sup>	-	12,60	-	-	125	70	348	174	350	246	792	21	160	250	354	325	917	210	310	323	254	15	150
100-080-200 <sup>53)</sup>	-	-	15,00	-	125	70	348	174	350	246	792	21	160	250	354	325	917	210	310	323	254	15	150
100-080-200 <sup>53)</sup>	-	-	18,50	-	125	70	348	174	350	246	828	21	160	250	354	325	953	254	314	323	254	15	150
100-080-200	-	-	22,00	-	125	80	348	174	350	246	863	23	180	250	367	370	988	241	343	368	279	15	150
100-080-200 <sup>53)</sup>	-	-	30,00	-	125	85	348	174	400	246	915	30	200	250	379	422	1040	305	388	404	318	19	150
100-080-200 <sup>53)</sup>	-	-	37,00	-	125	85	348	174	400	246	915	30	200	250	379	422	1040	305	388	404	318	19	150
100-080-200 <sup>53)</sup>	-	-	45,00	-	125	100	348	174	450	277	1032	35	225	250	426	468	1157	311	412	458	356	19	150
100-080-250 <sup>52)</sup>	5,50	6,30	-	-	125	55	348	174	300	213	670	15	132	280	302	274	795	140	220	270	216	12	150
100-080-250 <sup>52)</sup>	7,50	8,60	-	-	125	59	348	174	300	213	670	15	132	280	302	298	795	178	240	270	216	12	150
100-080-250 <sup>53)</sup>	11,00	12,60	-	-	125	70	348	174	350	246	792	21	160	280	354	325	917	210	310	323	254	15	150
100-080-250 <sup>53)</sup>	15,00	17,30	-	-	125	70	348	174	350	246	828	21	160	280	354	325	953	254	314	323	254	15	150
100-080-250	-	21,30	-	-	125	80	348	174	350	246	863	23	180	280	367	370	988	241	343	368	279	15	150

<sup>51</sup> Tolerances of mating dimensions to EN 735

<sup>52</sup> On this size, the motor feet must be shimmed (45 mm).

<sup>53</sup> On this size, the motor feet must be shimmed (20 mm).

## Etachrom B 25, with ball feet

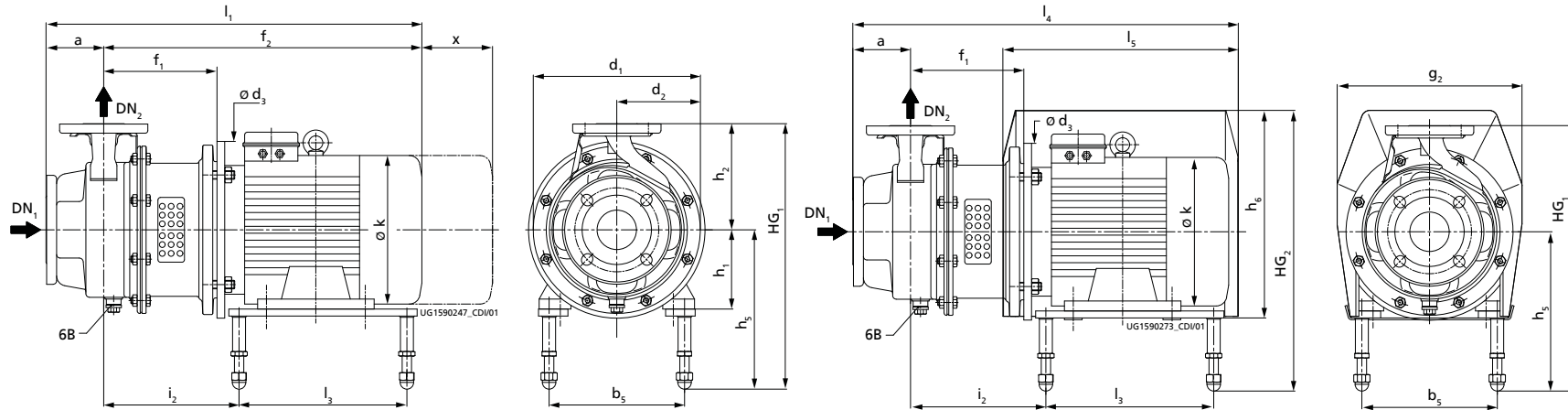

Etachrom B with 4-point ball feet, without motor shroud

Etachrom B with 4-point ball feet, with motor shroud

Table 38: Dimensions<sup>54)</sup>

Size	1450 rpm	1750 rpm	2900 rpm	3500 rpm	Motor	a	b <sub>5</sub>	d <sub>1</sub>	d <sub>2</sub>	d <sub>3</sub>	f <sub>1</sub>	f <sub>2</sub>	g <sub>2</sub>	h <sub>1</sub>	h <sub>2</sub>	h <sub>5</sub> min.	h <sub>5</sub> max.	h <sub>6</sub>	HG <sub>1</sub> max.	HG <sub>2</sub> max.	i <sub>2</sub>	k	l <sub>1</sub>	l <sub>3</sub>	l <sub>4</sub>	l <sub>5</sub>	x
	[kW]																										
050-025-125.1	0,55	0,63	-	-	80M	80	200	219	110	200	158	427	264	80	140	203	238	305	378	463	156	162	507	205	645	450	115
050-025-125.1	-	-	0,75	-	80M	80	200	219	110	200	158	427	264	80	140	203	238	305	378	463	156	162	507	205	645	450	115
050-025-125.1	-	-	1,10	1,27	80M	80	200	219	110	200	158	459	264	80	140	203	238	305	378	463	156	162	539	205	645	450	115
050-025-125.1	-	-	1,50	1,75	90S	80	200	219	110	200	158	512	264	90	140	213	248	305	388	463	152	190	592	225	651	450	115
050-025-125.1	-	-	2,20	2,55	90L	80	200	219	110	200	158	512	264	90	140	213	248	305	388	463	164	190	592	225	651	450	115
050-025-125.1	-	-	3,00	3,45	100L	80	200	219	110	250	168	558	264	100	140	223	258	305	398	463	169	213	638	265	691	470	115
050-025-125.1	-	-	4,00	4,55	112M	80	200	219	110	250	168	540	264	112	140	222	257	305	397	450	176	235	620	265	687	470	115
050-025-125	0,55	0,63	-	-	80M	80	200	219	110	200	158	427	264	80	140	203	238	305	378	463	156	162	507	205	645	450	115
050-025-125	-	-	0,75	-	80M	80	200	219	110	200	158	427	264	80	140	203	238	305	378	463	156	162	507	205	645	450	115
050-025-125	-	-	1,10	-	80M	80	200	219	110	200	158	459	264	80	140	203	238	305	378	463	156	162	539	205	645	450	115
050-025-125	-	-	1,50	1,75	90S	80	200	219	110	200	158	512	264	90	140	213	248	305	388	463	152	190	592	225	651	450	115
050-025-125	-	-	2,20	2,55	90L	80	200	219	110	200	158	512	264	90	140	213	248	305	388	463	164	190	592	225	651	450	115
050-025-125	-	-	3,00	3,45	100L	80	200	219	110	250	168	558	264	100	140	223	258	305	398	463	169	213	638	265	691	470	115
050-025-125	-	-	4,00	4,55	112M	80	200	219	110	250	168	540	264	112	140	222	257	305	397	450	176	235	620	265	687	470	115
050-025-160	0,55	0,63	-	-	80M	80	200	254	127	200	158	427	264	80	160	203	238	305	398	463	156	162	507	205	645	450	115

<sup>54)</sup> Tolerances of mating dimensions to EN 735



Size	1450 rpm	1750 rpm	2900 rpm	3500 rpm	Motor	a	b <sub>5</sub>	d <sub>1</sub>	d <sub>2</sub>	d <sub>3</sub>	f <sub>1</sub>	f <sub>2</sub>	g <sub>2</sub>	h <sub>1</sub>	h <sub>2</sub>	h <sub>5</sub> min.	h <sub>5</sub> max.	h <sub>6</sub>	HG <sub>1</sub> max.	HG <sub>2</sub> max.	i <sub>2</sub>	k	l <sub>1</sub>	l <sub>3</sub>	l <sub>4</sub>	l <sub>5</sub>	x
	[kW]					[mm]																					
050-025-160	-	0,86	-	-	80M	80	200	254	127	200	158	459	264	80	160	203	238	305	398	463	156	162	539	205	645	450	115
050-025-160	-	1,27	-	-	90S	80	200	254	127	200	158	512	264	90	160	213	248	305	408	463	152	190	592	225	651	450	115
050-025-160	-	-	1,50	-	90S	80	200	254	127	200	158	512	264	90	160	213	248	305	408	463	152	190	592	225	651	450	115
050-025-160	-	-	2,20	2,55	90L	80	200	254	127	200	158	512	264	90	160	213	248	305	408	463	164	190	592	225	651	450	115
050-025-160	-	-	3,00	3,45	100L	80	200	254	127	250	168	558	264	100	160	223	258	305	418	463	169	213	638	265	691	470	115
050-025-160	-	-	4,00	4,55	112M	80	200	254	127	250	168	540	264	112	160	222	257	305	417	450	176	235	620	265	687	470	115
050-025-160	-	-	-	6,30	132S	80	230	254	127	300	188	601	314	132	160	242	277	350	437	495	205	274	681	285	787	550	115
050-025-160	-	-	-	8,60	132S	80	230	254	127	300	188	645	314	132	160	242	277	350	437	495	205	274	725	285	787	550	115
050-025-200	0,55	-	-	-	80M	80	200	284	142	200	158	427	264	80	180	203	238	305	418	463	156	162	507	205	645	450	115
050-025-200	0,75	0,86	-	-	80M	80	200	284	142	200	158	459	264	80	180	203	238	305	418	463	156	162	539	205	645	450	115
050-025-200	1,10	1,27	-	-	90S	80	200	284	142	200	158	512	264	90	180	213	248	305	428	463	152	190	592	225	651	450	115
050-025-200	-	1,75	-	-	90L	80	200	284	142	200	158	512	264	90	180	213	248	305	428	463	164	190	592	225	651	450	115
050-025-200	-	2,55	-	-	100L	80	200	284	142	250	168	558	264	100	180	223	258	305	438	463	169	213	638	265	691	470	115
050-025-200	-	-	3,00	-	100L	80	200	284	142	250	168	558	264	100	180	223	258	305	438	463	169	213	638	265	691	470	115
050-025-200	-	-	4,00	4,55	112M	80	200	284	142	250	168	540	264	112	180	222	257	305	437	450	176	235	620	265	687	470	115
050-025-200	-	-	5,50	6,30	132S	80	230	284	142	300	188	601	314	132	180	242	277	350	457	495	205	274	681	285	787	550	115
050-025-200	-	-	7,50	8,60	132S	80	230	284	142	300	188	645	314	132	180	242	277	350	457	495	205	274	725	285	787	550	115
050-025-200	-	-	-	12,60	160M	80	280	284	142	350	218	764	372	160	180	270	305	423	485	568	239	325	844	385	965	720	115
050-025-200	-	-	-	17,30	160M	80	280	284	142	350	218	764	372	160	180	270	305	423	485	568	239	325	844	385	965	720	115
050-025-250	0,75	-	-	-	80M	100	200	348	174	200	156	457	264	80	225	203	238	305	463	463	99	162	557	260	663	450	130
050-025-250	1,10	1,27	-	-	90S	100	200	348	174	200	156	510	264	90	225	213	248	305	473	463	95	190	610	280	669	450	130
050-025-250	1,50	1,75	-	-	90L	100	200	348	174	200	156	510	264	90	225	213	248	305	473	463	107	190	610	280	669	450	130
050-025-250	-	2,55	-	-	100L	100	200	348	174	250	170	560	264	100	225	223	258	305	483	463	126	213	660	310	713	470	130
050-025-250	-	3,45	-	-	100L	100	200	348	174	250	170	560	264	100	225	223	258	305	483	463	126	213	660	310	713	470	130
050-025-250	-	-	5,50	-	132S	100	230	348	174	300	193	606	314	132	225	242	277	350	502	495	150	274	706	345	812	550	130
050-025-250	-	-	7,50	-	132S	100	230	348	174	300	193	650	314	132	225	242	277	350	502	495	150	274	750	345	812	550	130
050-025-250	-	-	11,00	-	160M	100	280	348	174	350	226	772	372	160	225	270	305	423	530	568	247	325	872	385	993	720	130
050-025-250	-	-	15,00	-	160M	100	280	348	174	350	226	772	372	160	225	270	305	423	530	568	247	325	872	385	993	720	130

## Etachrom B 32, with ball feet

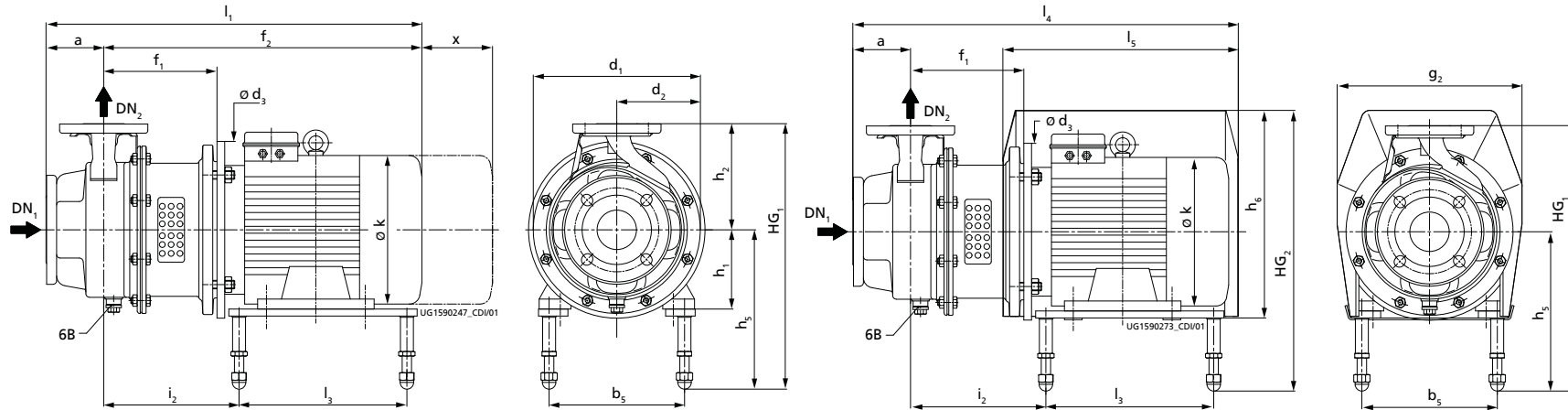

Etachrom B with 4-point ball feet, without motor shroud

Etachrom B with 4-point ball feet, with motor shroud

Table 39: Dimensions

Size	1450 rpm	1750 rpm	2900 rpm	3500 rpm	Motor	a	b <sub>5</sub>	d <sub>1</sub>	d <sub>2</sub>	d <sub>3</sub>	f <sub>1</sub>	f <sub>2</sub>	g <sub>2</sub>	h <sub>1</sub>	h <sub>2</sub>	h <sub>5</sub> min.	h <sub>5</sub> max.	h <sub>6</sub>	HG <sub>1</sub> max.	HG <sub>2</sub> max.	i <sub>2</sub>	k	l <sub>1</sub>	l <sub>3</sub>	l <sub>4</sub>	l <sub>5</sub>	x
	[kW]																										
050-032-125.1	0,55	0,63	-	-	80M	80	200	219	110	200	158	427	264	80	140	203	238	305	378	463	156	162	507	205	645	450	115
050-032-125.1	-	0,86	-	-	80M	80	200	219	110	200	158	459	264	80	140	203	238	305	378	463	156	162	539	205	645	450	115
050-032-125.1	-	-	0,75	-	80M	80	200	219	110	200	158	427	264	80	140	203	238	305	378	463	156	162	507	205	645	450	115
050-032-125.1	-	-	1,10	-	80M	80	200	219	110	200	158	459	264	80	140	203	238	305	378	463	156	162	539	205	645	450	115
050-032-125.1	-	-	1,50	1,75	90S	80	200	219	110	200	158	512	264	90	140	213	248	305	388	463	152	190	592	225	651	450	115
050-032-125.1	-	-	-	2,55	90L	80	200	219	110	200	158	512	264	90	140	213	248	305	388	463	164	190	592	225	651	450	115
050-032-125.1	-	-	-	3,45	100L	80	200	219	110	250	168	558	264	100	140	223	258	305	398	463	169	213	638	265	691	470	115
050-032-125.1	-	-	-	4,55	112M	80	200	219	110	250	168	540	264	112	140	222	257	305	397	450	176	235	620	265	687	470	115
050-032-125	0,55	0,63	-	-	80M	80	200	219	110	200	158	427	264	80	140	203	238	305	378	463	156	162	507	205	645	450	115
050-032-125	-	0,86	-	-	80M	80	200	219	110	200	158	459	264	80	140	203	238	305	378	463	156	162	539	205	645	450	115
050-032-125	-	-	1,50	-	90S	80	200	219	110	200	158	512	264	90	140	213	248	305	388	463	152	190	592	225	651	450	115
050-032-125	-	-	2,20	2,55	90L	80	200	219	110	200	158	512	264	90	140	213	248	305	388	463	164	190	592	225	651	450	115
050-032-125	-	-	3,00	3,45	100L	80	200	219	110	250	168	558	264	100	140	223	258	305	398	463	169	213	638	265	691	470	115
050-032-125	-	-	-	4,55	112M	80	200	219	110	250	168	540	264	112	140	222	257	305	397	450	176	235	620	265	687	470	115
050-032-160	0,55	0,63	-	-	80M	80	200	254	127	200	158	427	264	80	160	203	238	305	398	463	156	162	507	205	645	450	115

<sup>55)</sup> Tolerances of mating dimensions to EN 735

Size	1450 rpm	1750 rpm	2900 rpm	3500 rpm	Motor	a	b <sub>5</sub>	d <sub>1</sub>	d <sub>2</sub>	d <sub>3</sub>	f <sub>1</sub>	f <sub>2</sub>	g <sub>2</sub>	h <sub>1</sub>	h <sub>2</sub>	h <sub>5</sub> min.	h <sub>5</sub> max.	h <sub>6</sub>	HG <sub>1</sub> max.	HG <sub>2</sub> max.	i <sub>2</sub>	k	l <sub>1</sub>	l <sub>3</sub>	l <sub>4</sub>	l <sub>5</sub>	x
	[kW]					[mm] <sup>55)</sup>																					
050-032-160	0,75	0,86	-	-	80M	80	200	254	127	200	158	459	264	80	160	203	238	305	398	463	156	162	539	205	645	450	115
050-032-160	-	1,27	-	-	90S	80	200	254	127	200	158	512	264	90	160	213	248	305	408	463	152	190	592	225	651	450	115
050-032-160	-	1,75	-	-	90L	80	200	254	127	200	158	512	264	90	160	213	248	305	408	463	164	190	592	225	651	450	115
050-032-160	-	-	2,20	-	90L	80	200	254	127	200	158	512	264	90	160	213	248	305	408	463	164	190	592	225	651	450	115
050-032-160	-	-	3,00	3,45	100L	80	200	254	127	250	168	558	264	100	160	223	258	305	418	463	169	213	638	265	691	470	115
050-032-160	-	-	4,00	4,55	112M	80	200	254	127	250	168	540	264	112	160	222	257	305	417	450	176	235	620	265	687	470	115
050-032-160	-	-	5,50	6,30	132S	80	230	254	127	300	188	601	314	132	160	242	277	350	437	495	205	274	681	285	787	550	115
050-032-160	-	-	-	8,60	132S	80	230	254	127	300	188	645	314	132	160	242	277	350	437	495	205	274	725	285	787	550	115
050-032-160	-	-	-	12,60	160M	80	280	254	127	350	218	764	372	160	160	270	305	423	465	568	239	325	844	385	965	720	115
050-032-200	0,55	-	-	-	80M	80	200	284	142	200	158	427	264	80	180	203	238	305	418	463	156	162	507	205	645	450	115
050-032-200	0,75	-	-	-	80M	80	200	284	142	200	158	459	264	80	180	203	238	305	418	463	156	162	539	205	645	450	115
050-032-200	1,10	1,27	-	-	90S	80	200	284	142	200	158	512	264	90	180	213	248	305	428	463	152	190	592	225	651	450	115
050-032-200	-	1,75	-	-	90L	80	200	284	142	200	158	512	264	90	180	213	248	305	428	463	164	190	592	225	651	450	115
050-032-200	-	2,55	-	-	100L	80	200	284	142	250	168	558	264	100	180	223	258	305	438	463	169	213	638	265	691	470	115
050-032-200	-	-	3,00	-	100L	80	200	284	142	250	168	558	264	100	180	223	258	305	438	463	169	213	638	265	691	470	115
050-032-200	-	-	4,00	-	112M	80	200	284	142	250	168	540	264	112	180	222	257	305	437	450	176	235	620	265	687	470	115
050-032-200	-	-	5,50	6,30	132S	80	230	284	142	300	188	601	314	132	180	242	277	350	457	495	205	274	681	285	787	550	115
050-032-200	-	-	7,50	8,60	132S	80	230	284	142	300	188	645	314	132	180	242	277	350	457	495	205	274	725	285	787	550	115
050-032-200	-	-	11,00	12,60	160M	80	280	284	142	350	218	764	372	160	180	270	305	423	485	568	239	325	844	385	965	720	115
050-032-200	-	-	-	17,30	160M	80	280	284	142	350	218	764	372	160	180	270	305	423	485	568	239	325	844	385	965	720	115
050-032-250	0,75	-	-	-	80M	100	200	348	174	200	156	457	264	80	225	203	238	305	463	463	99	162	557	260	663	450	130
050-032-250	1,10	-	-	-	90S	100	200	348	174	200	156	510	264	90	225	213	248	305	473	463	95	190	610	280	669	450	130
050-032-250	1,50	1,75	-	-	90L	100	200	348	174	200	156	510	264	90	225	213	248	305	473	463	107	190	610	280	669	450	130
050-032-250	2,20	2,55	-	-	100L	100	200	348	174	250	170	560	264	100	225	223	258	305	483	463	126	213	660	310	713	470	130
050-032-250	3,00	3,45	-	-	100L	100	200	348	174	250	170	560	264	100	225	223	258	305	483	463	126	213	660	310	713	470	130
050-032-250	-	4,55	-	-	112M	100	200	348	174	250	170	542	264	112	225	222	257	305	482	450	113	235	642	330	709	470	130
050-032-250	-	6,30	-	-	132S	100	230	348	174	300	193	650	314	132	225	242	277	350	502	495	150	274	750	345	812	550	130
050-032-250	-	-	5,50	-	132S	100	230	348	174	300	193	606	314	132	225	242	277	350	502	495	150	274	706	345	812	550	130
050-032-250	-	-	7,50	-	132S	100	230	348	174	300	193	650	314	132	225	242	277	350	502	495	150	274	750	345	812	550	130
050-032-250	-	-	11,00	-	160M	100	280	348	174	350	226	772	372	160	225	270	305	423	530	568	247	325	872	385	993	720	130
050-032-250	-	-	15,00	-	160M	100	280	348	174	350	226	772	372	160	225	270	305	423	530	568	247	325	872	385	993	720	130
050-032-250	-	-	18,50	-	160L	100	280	348	174	350	226	808	372	160	225	270	305	423	530	568	269	325	908	385	993	720	130

Etachrom B 40, with ball feet

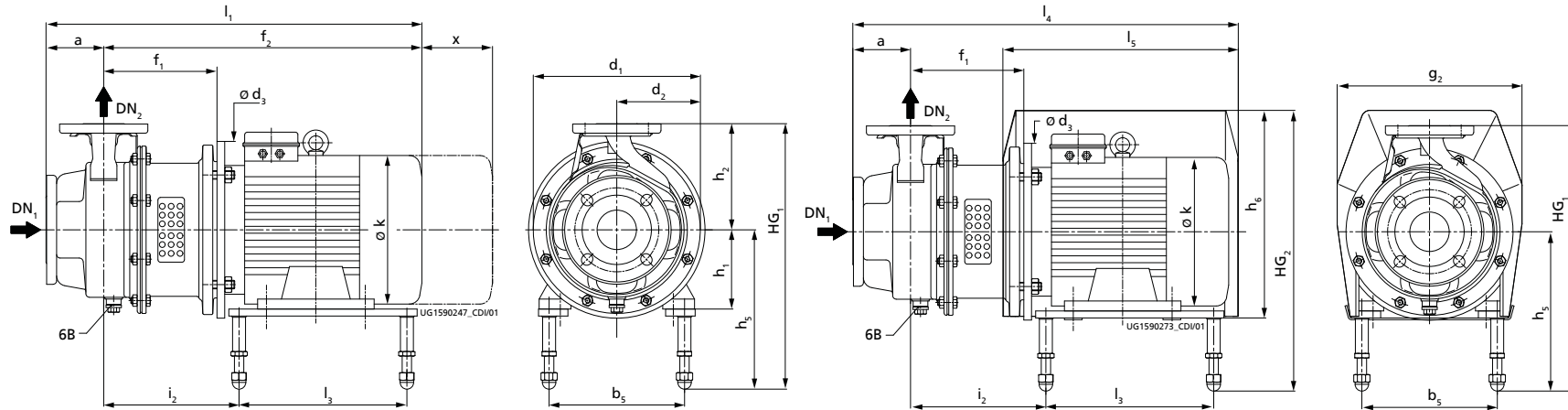

Etachrom B with 4-point ball feet, without motor shroud

Etachrom B with 4-point ball feet, with motor shroud

Table 40: Dimensions<sup>56)</sup>

Size	1450 rpm	1750 rpm	2900 rpm	3500 rpm	Motor	a	b <sub>5</sub>	d <sub>1</sub>	d <sub>2</sub>	d <sub>3</sub>	f <sub>1</sub>	f <sub>2</sub>	g <sub>2</sub>	h <sub>1</sub>	h <sub>2</sub>	h <sub>5</sub> min.	h <sub>5</sub> max.	h <sub>6</sub>	HG <sub>1</sub> max.	HG <sub>2</sub> max.	i <sub>2</sub>	k	l <sub>1</sub>	l <sub>3</sub>	l <sub>4</sub>	l <sub>5</sub>	x
	[kW]																										
065-040-125	0,55	0,63	-	-	80M	80	200	219	110	200	160	429	264	80	140	203	238	305	378	463	158	162	509	205	647	450	115
065-040-125	-	0,86	-	-	80M	80	200	219	110	200	160	461	264	80	140	203	238	305	378	463	158	162	541	205	647	450	115
065-040-125	-	1,27	-	-	90S	80	200	219	110	200	160	514	264	90	140	213	248	305	388	463	154	190	594	225	653	450	115
065-040-125	-	-	1,50	-	90S	80	200	219	110	200	160	514	264	90	140	213	248	305	388	463	154	190	594	225	653	450	115
065-040-125	-	-	2,20	2,55	90L	80	200	219	110	200	160	514	264	90	140	213	248	305	388	463	166	190	594	225	653	450	115
065-040-125	-	-	3,00	3,45	100L	80	200	219	110	250	170	560	264	100	140	223	258	305	398	463	171	213	640	265	693	470	115
065-040-125	-	-	4,00	4,55	112M	80	200	219	110	250	170	542	264	112	140	222	257	305	397	450	178	235	622	265	689	470	115
065-040-160	0,55	-	-	-	80M	80	200	254	127	200	160	429	264	80	160	203	238	305	398	463	158	162	509	205	647	450	115
065-040-160	0,75	-	-	-	80M	80	200	254	127	200	160	461	264	80	160	203	238	305	398	463	158	162	541	205	647	450	115
065-040-160	1,10	1,27	-	-	90S	80	200	254	127	200	160	514	264	90	160	213	248	305	408	463	154	190	594	225	653	450	115
065-040-160	1,50	1,75	-	-	90L	80	200	254	127	200	160	514	264	90	160	213	248	305	408	463	166	190	594	225	653	450	115
065-040-160	-	2,55	-	-	100L	80	200	254	127	250	170	560	264	100	160	223	258	305	418	463	171	213	640	265	693	470	115
065-040-160	-	-	3,00	-	100L	80	200	254	127	250	170	560	264	100	160	223	258	305	418	463	171	213	640	265	693	470	115
065-040-160	-	-	4,00	-	112M	80	200	254	127	250	170	542	264	112	160	222	257	305	417	450	178	235	622	265	689	470	115
065-040-160	-	-	5,50	6,30	132S	80	230	254	127	300	190	603	314	132	160	242	277	350	437	495	207	274	683	285	789	550	115

<sup>56)</sup> Tolerances of mating dimensions to EN 735

Size	1450 rpm	1750 rpm	2900 rpm	3500 rpm	Motor	a	b <sub>5</sub>	d <sub>1</sub>	d <sub>2</sub>	d <sub>3</sub>	f <sub>1</sub>	f <sub>2</sub>	g <sub>2</sub>	h <sub>1</sub>	h <sub>2</sub>	h <sub>5</sub> min.	h <sub>5</sub> max.	h <sub>6</sub>	HG <sub>1</sub> max.	HG <sub>2</sub> max.	i <sub>2</sub>	k	l <sub>1</sub>	l <sub>3</sub>	l <sub>4</sub>	l <sub>5</sub>	x
	[kW]					[mm]																					
065-040-160	-	-	7,50	8,60	132S	80	230	254	127	300	190	647	314	132	160	242	277	350	437	495	207	274	727	285	789	550	115
065-040-160	-	-	11,00	12,60	160M	80	280	254	127	350	220	766	372	160	160	270	305	423	465	568	241	325	846	385	967	720	115
065-040-160	-	-	-	17,30	160M	80	280	254	127	350	220	766	372	160	160	270	305	423	465	568	241	325	846	385	967	720	115
065-040-200	0,75	-	-	-	80M	100	200	284	142	200	160	461	264	80	180	203	238	305	418	463	158	162	561	205	667	450	115
065-040-200	1,10	1,27	-	-	90S	100	200	284	142	200	160	514	264	90	180	213	248	305	428	463	154	190	614	225	673	450	115
065-040-200	1,50	1,75	-	-	90L	100	200	284	142	200	160	514	264	90	180	213	248	305	428	463	166	190	614	225	673	450	115
065-040-200	-	2,55	-	-	100L	100	200	284	142	250	170	560	264	100	180	223	258	305	438	463	171	213	660	265	713	470	115
065-040-200	-	3,45	-	-	100L	100	200	284	142	250	170	560	264	100	180	223	258	305	438	463	171	213	660	265	713	470	115
065-040-200	-	-	5,50	-	132S	100	230	284	142	300	190	603	314	132	180	242	277	350	457	495	207	274	703	285	809	550	115
065-040-200	-	-	7,50	-	132S	100	230	284	142	300	190	647	314	132	180	242	277	350	457	495	207	274	747	285	809	550	115
065-040-200	-	-	11,00	12,60	160M	100	280	284	142	350	220	766	372	160	180	270	305	423	485	568	241	325	866	385	987	720	115
065-040-200	-	-	-	17,30	160M	100	280	284	142	350	220	766	372	160	180	270	305	423	485	568	241	325	866	385	987	720	115
065-040-200	-	-	-	21,30	160L	100	280	284	142	350	220	802	372	160	180	270	305	423	485	568	263	325	902	385	987	720	115
065-040-250	1,10	-	-	-	90S	100	200	348	174	200	156	510	264	90	225	213	248	305	473	463	95	190	610	280	669	450	130
065-040-250	1,50	1,75	-	-	90L	100	200	348	174	200	156	510	264	90	225	213	248	305	473	463	107	190	610	280	669	450	130
065-040-250	2,20	2,55	-	-	100L	100	200	348	174	250	170	560	264	100	225	223	258	305	483	463	126	213	660	310	713	470	130
065-040-250	3,00	3,45	-	-	100L	100	200	348	174	250	170	560	264	100	225	223	258	305	483	463	126	213	660	310	713	470	130
065-040-250	-	4,55	-	-	112M	100	200	348	174	250	170	542	264	112	225	222	257	305	482	450	113	235	642	330	709	470	130
065-040-250	-	6,30	-	-	132S	100	230	348	174	300	193	650	314	132	225	242	277	350	502	495	150	274	750	345	812	550	130
065-040-250	-	-	7,50	-	132S	100	230	348	174	300	193	650	314	132	225	242	277	350	502	495	150	274	750	345	812	550	130
065-040-250	-	-	11,00	-	160M	100	280	348	174	350	226	772	372	160	225	270	305	423	530	568	247	325	872	385	993	720	130
065-040-250	-	-	15,00	-	160M	100	280	348	174	350	226	772	372	160	225	270	305	423	530	568	247	325	872	385	993	720	130
065-040-250	-	-	18,50	-	160L	100	280	348	174	350	226	808	372	160	225	270	305	423	530	568	269	325	908	385	993	720	130
065-040-250	-	-	22,00	-	180M	100	305	348	174	350	226	843	402	180	225	290	325	493	550	638	275	370	943	385	1005	740	130
065-040-250	-	-	30,00	-	200L	100	345	348	174	400	226	895	452	200	225	331	353	545	578	698	304	422	995	415	1144	830	130

## Etachrom B 50, with ball feet

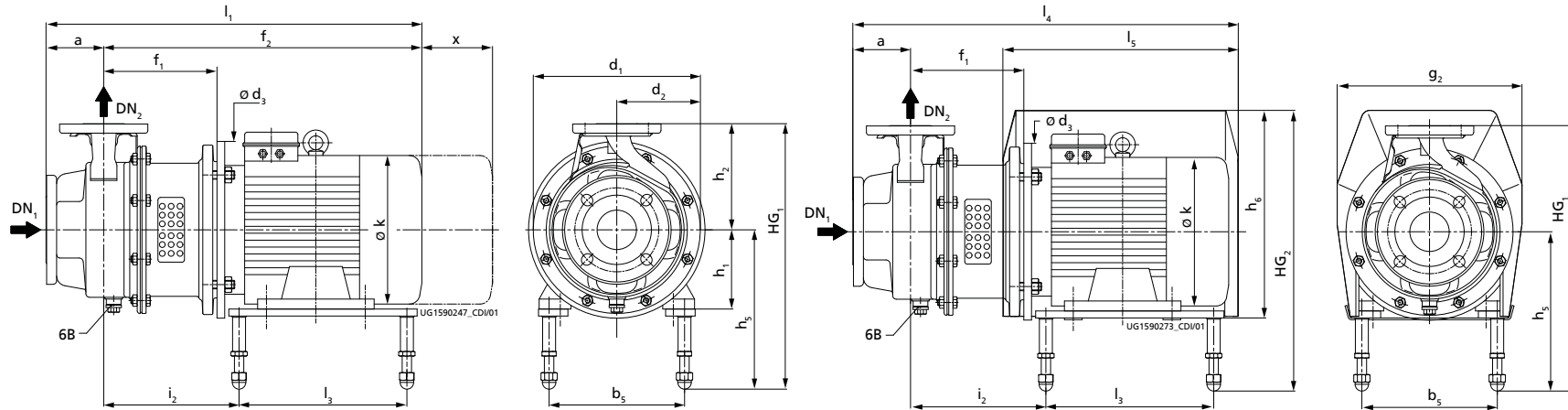

Etachrom B with 4-point ball feet, without motor shroud

Etachrom B with 4-point ball feet, with motor shroud

Table 41: Dimensions<sup>57)</sup>

Size	1450 rpm	1750 rpm	2900 rpm	3500 rpm	Motor	a	b <sub>5</sub>	d <sub>1</sub>	d <sub>2</sub>	d <sub>3</sub>	f <sub>1</sub>	f <sub>2</sub>	g <sub>2</sub>	h <sub>1</sub>	h <sub>2</sub>	h <sub>5</sub> min.	h <sub>5</sub> max.	h <sub>6</sub>	HG <sub>1</sub> max.	HG <sub>2</sub> max.	i <sub>2</sub>	k	l <sub>1</sub>	l <sub>3</sub>	l <sub>4</sub>	l <sub>5</sub>	x
	[kW]					[mm]																					
065-050-125	0,55	-	-	-	80M	100	200	254	127	200	160	429	264	80	160	203	238	305	398	463	158	162	529	205	667	450	130
065-050-125	0,75	0,86	-	-	80M	100	200	254	127	200	160	461	264	80	160	203	238	305	398	463	158	162	561	205	667	450	130
065-050-125	1,10	1,27	-	-	90S	100	200	254	127	200	160	514	264	90	160	213	248	305	408	463	154	190	614	225	673	450	130
065-050-125	-	1,75	-	-	90L	100	200	254	127	200	160	514	264	90	160	213	248	305	408	463	166	190	614	225	673	450	130
065-050-125	-	-	3,00	-	100L	100	200	254	127	250	170	560	264	100	160	223	258	305	418	463	171	213	660	265	713	470	130
065-050-125	-	-	4,00	-	112M	100	200	254	127	250	170	542	264	112	160	222	257	305	417	450	178	235	642	265	709	470	130
065-050-125	-	-	5,50	6,30	132S	100	230	254	127	300	190	603	314	132	160	242	277	350	437	495	207	274	703	285	809	550	130
065-050-125	-	-	7,50	8,60	132S	100	230	254	127	300	190	647	314	132	160	242	277	350	437	495	207	274	747	285	809	550	130
065-050-125	-	-	-	12,60	160M	100	280	254	127	350	220	766	372	160	160	270	305	423	465	568	241	325	866	385	987	720	130
065-050-125	-	-	-	17,30	160M	100	280	254	127	350	220	766	372	160	160	270	305	423	465	568	241	325	866	385	987	720	130
065-050-125 F	0,75	0,86	-	-	80M	100	200	254	127	200	160	461	264	80	160	203	238	305	398	463	158	162	561	205	667	450	130
065-050-125 F	-	1,27	-	-	90S	100	200	254	127	200	160	514	264	90	160	213	248	305	408	463	154	190	614	225	673	450	130
065-050-125 F	-	-	2,20	-	90L	100	200	254	127	200	160	514	264	90	160	213	248	305	408	463	166	190	614	225	673	450	130
065-050-125 F	-	-	3,00	3,45	100L	100	200	254	127	250	170	560	264	100	160	223	258	305	418	463	171	213	660	265	713	470	130
065-050-125 F	-	-	4,00	4,55	112M	100	200	254	127	250	170	542	264	112	160	222	257	305	417	450	178	235	642	265	709	470	130

<sup>57)</sup> Tolerances of mating dimensions to EN 735

Size	1450 rpm	1750 rpm	2900 rpm	3500 rpm	Motor	a	b <sub>5</sub>	d <sub>1</sub>	d <sub>2</sub>	d <sub>3</sub>	f <sub>1</sub>	f <sub>2</sub>	g <sub>2</sub>	h <sub>1</sub>	h <sub>2</sub>	h <sub>5</sub> min.	h <sub>5</sub> max.	h <sub>6</sub>	HG <sub>1</sub> max.	HG <sub>2</sub> max.	i <sub>2</sub>	k	l <sub>1</sub>	l <sub>3</sub>	l <sub>4</sub>	l <sub>5</sub>	x
	[kW]					[mm]																					
065-050-125 F	-	-	5,50	6,30	132S	100	230	254	127	300	190	603	314	132	160	242	277	350	437	495	207	274	703	285	809	550	130
065-050-125 F	-	-	-	8,60	132S	100	230	254	127	300	190	647	314	132	160	242	277	350	437	495	207	274	747	285	809	550	130
065-050-160	0,75	-	-	-	80M	100	200	254	127	200	160	461	264	80	180	203	238	305	418	463	158	162	561	205	667	450	130
065-050-160	1,10	1,27	-	-	90S	100	200	254	127	200	160	514	264	90	180	213	248	305	428	463	154	190	614	225	673	450	130
065-050-160	1,50	1,75	-	-	90L	100	200	254	127	200	160	514	264	90	180	213	248	305	428	463	166	190	614	225	673	450	130
065-050-160	2,20	2,55	-	-	100L	100	200	254	127	250	170	560	264	100	180	223	258	305	438	463	171	213	660	265	713	470	130
065-050-160	-	3,45	-	-	100L	100	200	254	127	250	170	560	264	100	180	223	258	305	438	463	171	213	660	265	713	470	130
065-050-160	-	-	5,50	-	132S	100	230	254	127	300	190	603	314	132	180	242	277	350	457	495	207	274	703	285	809	550	130
065-050-160	-	-	7,50	-	132S	100	230	254	127	300	190	647	314	132	180	242	277	350	457	495	207	274	747	285	809	550	130
065-050-160	-	-	11,00	12,60	160M	100	280	254	127	350	220	766	372	160	180	270	305	423	485	568	241	325	866	385	987	720	130
065-050-160	-	-	15,00	17,30	160M	100	280	254	127	350	220	766	372	160	180	270	305	423	485	568	241	325	866	385	987	720	130
065-050-160	-	-	-	21,30	160L	100	280	254	127	350	220	802	372	160	180	270	305	423	485	568	263	325	902	385	987	720	130
065-050-200	0,75	-	-	-	80M	100	200	313	157	200	156	457	264	80	200	203	238	305	438	463	99	162	557	260	663	450	130
065-050-200	1,10	-	-	-	90S	100	200	313	157	200	156	510	264	90	200	213	248	305	448	463	95	190	610	280	669	450	130
065-050-200	1,50	1,75	-	-	90L	100	200	313	157	200	156	510	264	90	200	213	248	305	448	463	107	190	610	280	669	450	130
065-050-200	2,20	2,55	-	-	100L	100	200	313	157	250	170	560	264	100	200	223	258	305	458	463	126	213	660	310	713	470	130
065-050-200	3,00	3,45	-	-	100L	100	200	313	157	250	170	560	264	100	200	223	258	305	458	463	126	213	660	310	713	470	130
065-050-200	4,00	4,55	-	-	112M	100	200	313	157	250	170	542	264	112	200	222	257	305	457	450	113	235	642	330	709	470	130
065-050-200	-	6,30	-	-	132S	100	230	313	157	300	193	650	314	132	200	242	277	350	477	495	150	274	750	345	812	550	130
065-050-200	-	-	5,50	-	132S	100	230	313	157	300	193	606	314	132	200	242	277	350	477	495	150	274	706	345	812	550	130
065-050-200	-	-	7,50	-	132S	100	230	313	157	300	193	650	314	132	200	242	277	350	477	495	150	274	750	345	812	550	130
065-050-200	-	-	11,00	12,60	160M	100	280	313	157	350	226	772	372	160	200	270	305	423	505	568	247	325	872	385	993	720	130
065-050-200	-	-	15,00	17,30	160M	100	280	313	157	350	226	772	372	160	200	270	305	423	505	568	247	325	872	385	993	720	130
065-050-200	-	-	18,50	21,30	160L	100	280	313	157	350	226	808	372	160	200	270	305	423	505	568	269	325	908	385	993	720	130
065-050-200	-	-	22,00	24,50	180M	100	305	313	157	350	226	843	402	180	200	290	325	493	525	638	275	370	943	385	1005	740	130
065-050-200	-	-	-	33,50	200L	100	345	313	157	400	226	895	452	200	200	331	353	545	553	698	304	422	995	415	1144	830	130
065-050-200	-	-	-	41,50	200L	100	345	313	157	400	226	895	452	200	200	331	353	545	553	698	304	422	995	415	1144	830	130
065-050-250	1,50	-	-	-	90L	100	200	348	174	200	156	510	264	90	225	213	248	305	473	463	107	190	610	280	669	450	130
065-050-250	2,20	2,55	-	-	100L	100	200	348	174	250	170	560	264	100	225	223	258	305	483	463	126	213	660	310	713	450	130
065-050-250	3,00	3,45	-	-	100L	100	200	348	174	250	170	560	264	100	225	223	258	305	483	463	126	213	660	310	713	470	130
065-050-250	4,00	4,55	-	-	112M	100	200	348	174	250	170	542	264	112	225	222	257	305	482	450	113	235	642	330	709	470	130
065-050-250	-	6,30	-	-	132S	100	230	348	174	300	193	650	314	132	225	242	277	350	502	495	150	274	750	345	812	550	130
065-050-250	-	8,60	-	-	132M	100	230	348	174	300	193	650	314	132	225	242	277	350	502	495	169	298	750	345	812	550	130
065-050-250	-	12,60	-	-	160M	100	280	348	174	350	226	772	372	160	225	270	305	423	530	568	247	325	872	385	993	720	130
065-050-250	-	-	15,00	-	160M	100	280	348	174	350	226	772	372	160	225	270	305	423	530	568	247	325	872	385	993	720	130
065-050-250	-	-	18,50	-	160L	100	280	348	174	350	226	808	372	160	225	270	305	423	530	568	269	325	908	385	993	720	130

Size	1450 rpm	1750 rpm	2900 rpm	3500 rpm	Motor	a	b <sub>5</sub>	d <sub>1</sub>	d <sub>2</sub>	d <sub>3</sub>	f <sub>1</sub>	f <sub>2</sub>	g <sub>2</sub>	h <sub>1</sub>	h <sub>2</sub>	h <sub>5</sub> min.	h <sub>5</sub> max.	h <sub>6</sub>	HG <sub>1</sub> max.	HG <sub>2</sub> max.	i <sub>2</sub>	k	l <sub>1</sub>	l <sub>3</sub>	l <sub>4</sub>	l <sub>5</sub>	x
	[kW]					[mm]																					
065-050-250	-	-	22,00	-	180M	100	305	348	174	350	226	843	402	180	225	290	325	493	550	638	275	370	943	385	1005	740	130
065-050-250	-	-	30,00	-	200L	100	345	348	174	400	226	895	452	200	225	331	353	545	578	698	304	422	995	415	1144	830	130
065-050-250	-	-	37,00	-	200L	100	345	348	174	400	226	895	452	200	225	331	353	545	578	698	304	422	995	415	1144	830	130



Etachrom B 65, with ball feet

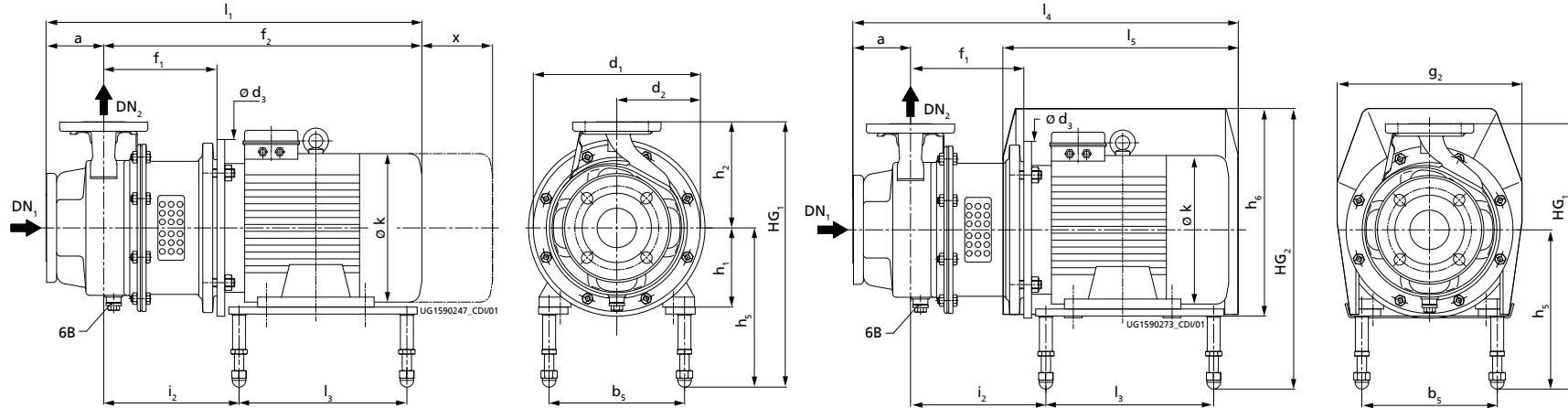

Etachrom B with 4-point ball feet, without motor shroud

Etachrom B with 4-point ball feet, with motor shroud

Table 42: Dimensions<sup>58)</sup>

Size	1450 rpm	1750 rpm	2900 rpm	3500 rpm	Motor	a	b <sub>5</sub>	d <sub>1</sub>	d <sub>2</sub>	d <sub>3</sub>	f <sub>1</sub>	f <sub>2</sub>	g <sub>2</sub>	h <sub>1</sub>	h <sub>2</sub>	h <sub>5</sub> min.	h <sub>5</sub> max.	h <sub>6</sub>	HG <sub>1</sub> max.	HG <sub>2</sub> max.	i <sub>2</sub>	k	l <sub>1</sub>	l <sub>3</sub>	l <sub>4</sub>	l <sub>5</sub>	x
	[kW]					[mm]																					
080-065-200	1,50	-	-	-	90L	100	200	348	174	200	156	510	264	90	225	213	248	305	473	463	107	190	610	280	669	450	130
080-065-200	2,20	2,55	-	-	100L	100	200	348	174	250	170	560	264	100	225	223	258	305	483	463	126	213	660	310	713	470	130
080-065-200	3,00	3,45	-	-	100L	100	200	348	174	250	170	560	264	100	225	223	258	305	483	463	126	213	660	310	713	470	130
080-065-200	4,00	4,55	-	-	112M	100	200	348	174	250	170	542	264	112	225	222	257	305	482	450	113	235	642	330	709	470	130
080-065-200	-	6,30	-	-	132S	100	230	348	174	300	193	650	314	132	225	242	277	350	502	495	150	274	750	345	812	550	130
080-065-200	-	8,60	-	-	132M	100	230	348	174	300	193	650	314	132	225	242	277	350	502	495	169	298	750	345	812	550	130
080-065-200	-	-	11,00	-	160M	100	280	348	174	350	226	772	372	160	225	270	305	423	530	568	247	325	872	385	993	720	130
080-065-200	-	-	15,00	-	160M	100	280	348	174	350	226	772	372	160	225	270	305	423	530	568	247	325	872	385	993	720	130
080-065-200	-	-	18,50	21,30	160L	100	280	348	174	350	226	808	372	160	225	270	305	423	530	568	269	325	908	385	993	720	130
080-065-200	-	-	22,00	24,50	180M	100	305	348	174	350	226	843	402	180	225	290	325	493	550	638	275	370	943	385	1005	740	130
080-065-200	-	-	30,00	33,50	200L	100	345	348	174	400	226	895	452	200	225	331	353	545	578	698	304	422	995	415	1144	830	130
080-065-200	-	-	37,00	41,50	200L	100	345	348	174	400	226	895	452	200	225	331	353	545	578	698	304	422	995	415	1144	830	130
080-065-250	2,20	-	-	-	100L	100	200	348	174	250	190	580	264	100	250	223	258	305	508	463	146	213	680	310	733	470	140
080-065-250	3,00	-	-	-	100L	100	200	348	174	250	190	580	264	100	250	223	258	305	508	463	146	213	680	310	733	470	140
080-065-250	4,00	4,55	-	-	112M	100	200	348	174	250	190	562	264	112	250	222	257	305	507	450	133	235	662	330	729	470	140

<sup>58)</sup> Tolerances of mating dimensions to EN 735

Size	1450 rpm	1750 rpm	2900 rpm	3500 rpm	Motor	a	b <sub>5</sub>	d <sub>1</sub>	d <sub>2</sub>	d <sub>3</sub>	f <sub>1</sub>	f <sub>2</sub>	g <sub>2</sub>	h <sub>1</sub>	h <sub>2</sub>	h <sub>5</sub> min.	h <sub>5</sub> max.	h <sub>6</sub>	HG <sub>1</sub> max.	HG <sub>2</sub> max.	i <sub>2</sub>	k	l <sub>1</sub>	l <sub>3</sub>	l <sub>4</sub>	l <sub>5</sub>	x
	[kW]					[mm]																					
080-065-250	5,50	6,30	-	-	132S	100	230	348	174	300	213	670	314	132	250	242	277	350	527	495	170	274	770	345	832	550	140
080-065-250	7,50	8,60	-	-	132M	100	230	348	174	300	213	670	314	132	250	242	277	350	527	495	189	298	770	345	832	550	140
080-065-250	-	12,60	-	-	160M	100	280	348	174	350	246	792	372	160	250	270	305	423	555	568	267	325	892	385	1013	720	140
080-065-250	-	-	15,00	-	160M	100	280	348	174	350	246	792	372	160	250	270	305	423	555	568	267	325	892	385	1013	720	150
080-065-250	-	-	18,50	-	160L	100	280	348	174	350	246	828	372	160	250	270	305	423	555	568	289	325	928	385	1013	720	150
080-065-250	-	-	22,00	-	180M	100	305	348	174	350	246	863	402	180	250	290	325	493	575	638	295	370	963	385	1025	740	150
080-065-250	-	-	30,00	-	200L	100	345	348	174	400	246	915	452	200	250	331	353	545	603	698	324	422	1015	415	1164	830	150
080-065-250	-	-	37,00	-	200L	100	345	348	174	400	246	915	452	200	250	331	353	545	603	698	324	422	1015	415	1164	830	150
080-065-250	-	-	45,00	-	225M	100	390	348	174	450	277	1032	527	225	250	356	378	616	628	769	354	468	1132	455	1331	950	150

Etachrom B 80, with ball feet

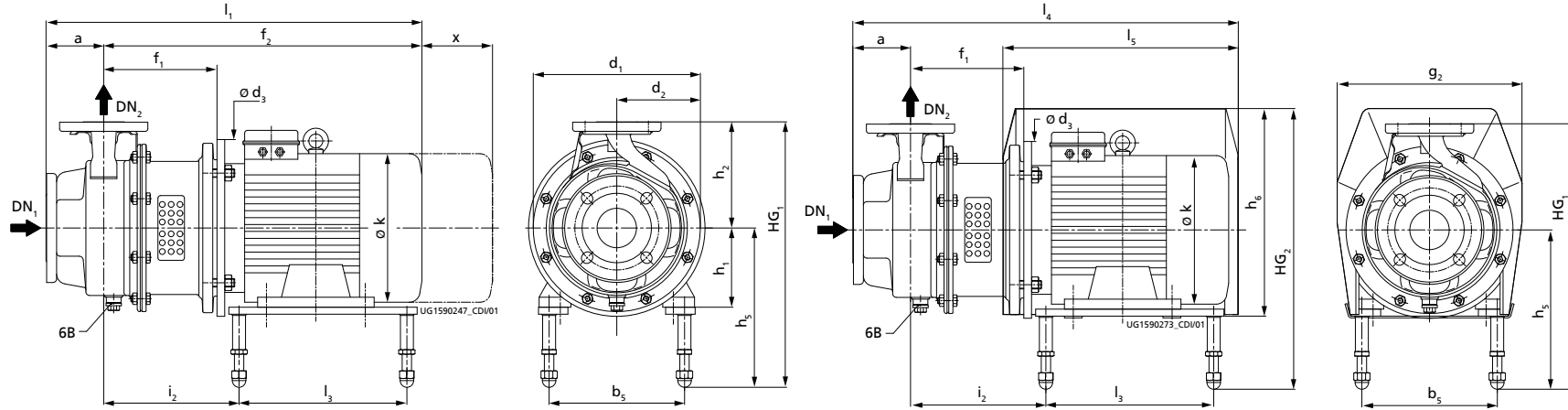

Etachrom B with 4-point ball feet, without motor shroud

Etachrom B with 4-point ball feet, with motor shroud

Table 43: Dimensions<sup>59)</sup>

Size	1450 rpm	1750 rpm	2900 rpm	3500 rpm	Motor	a	b <sub>5</sub>	d <sub>1</sub>	d <sub>2</sub>	d <sub>3</sub>	f <sub>1</sub>	f <sub>2</sub>	g <sub>2</sub>	h <sub>1</sub>	h <sub>2</sub>	h <sub>5</sub> min.	h <sub>5</sub> max.	h <sub>6</sub>	HG <sub>1</sub> max.	HG <sub>2</sub> max.	i <sub>2</sub>	k	l <sub>1</sub>	l <sub>3</sub>	l <sub>4</sub>	l <sub>5</sub>	x
	[kW]																										
100-080-200	2,20	-	-	-	100L	125	200	348	174	250	190	580	264	100	250	223	258	305	508	463	146	213	705	310	758	470	150
100-080-200	3,00	3,45	-	-	100L	125	200	348	174	250	190	580	264	100	250	223	258	305	508	463	146	213	705	310	758	470	150
100-080-200	4,00	4,55	-	-	112M	125	200	348	174	250	190	562	264	112	250	222	257	305	507	450	133	235	687	330	754	470	150
100-080-200	5,50	6,30	-	-	132S	125	230	348	174	300	213	670	314	132	250	242	277	350	527	495	170	274	795	345	857	550	150
100-080-200	7,50	8,60	-	-	132M	125	230	348	174	300	213	670	314	132	250	242	277	350	527	495	189	298	795	345	857	550	150
100-080-200	-	12,60	-	-	160M	125	280	348	174	350	246	792	372	160	250	270	305	423	555	568	267	325	917	385	1038	720	150
100-080-200	-	-	15,00	-	160M	125	280	348	174	350	246	792	372	160	250	270	305	423	555	568	267	325	917	385	1038	720	150
100-080-200	-	-	18,50	-	160L	125	280	348	174	350	246	828	372	160	250	270	305	423	555	568	289	325	953	385	1038	720	150
100-080-200	-	-	22,00	-	180M	125	305	348	174	350	246	863	402	180	250	290	325	493	575	638	295	370	988	385	1050	740	150
100-080-200	-	-	30,00	-	200L	125	345	348	174	400	246	915	452	200	250	331	353	545	603	698	324	422	1040	415	1189	830	150
100-080-200	-	-	37,00	-	200L	125	345	348	174	400	246	915	452	200	250	331	353	545	603	698	324	422	1040	415	1189	830	150
100-080-200	-	-	45,00	-	225M	125	390	348	174	450	277	1032	527	225	250	356	378	616	628	769	354	468	1157	455	1356	950	150
100-080-250	3,00	-	-	-	100L	125	200	348	174	250	190	580	264	100	280	223	258	305	538	463	146	213	705	310	758	470	150
100-080-250	4,00	-	-	-	112M	125	200	348	174	250	190	562	264	112	280	222	257	305	537	450	133	235	687	330	754	470	150
100-080-250	5,50	6,30	-	-	132S	125	230	348	174	300	213	670	314	132	280	242	277	350	557	495	170	274	795	345	857	550	150

<sup>59)</sup> Tolerances of mating dimensions to EN 735

Size	1450 rpm	1750 rpm	2900 rpm	3500 rpm	Motor	a	b <sub>5</sub>	d <sub>1</sub>	d <sub>2</sub>	d <sub>3</sub>	f <sub>1</sub>	f <sub>2</sub>	g <sub>2</sub>	h <sub>1</sub>	h <sub>2</sub>	h <sub>5</sub> min.	h <sub>5</sub> max.	h <sub>6</sub>	HG <sub>1</sub> max.	HG <sub>2</sub> max.	i <sub>2</sub>	k	l <sub>1</sub>	l <sub>3</sub>	l <sub>4</sub>	l <sub>5</sub>	x
	[kW]					[mm]																					
100-080-250	7,50	8,60	-	-	132M	125	230	348	174	300	213	670	314	132	280	242	277	350	557	495	189	298	795	345	857	550	150
100-080-250	11,00	12,60	-	-	160M	125	280	348	174	350	246	792	372	160	280	270	305	423	585	568	267	325	917	385	1038	720	150
100-080-250	15,00	17,30	-	-	160L	125	280	348	174	350	246	828	372	160	280	270	305	423	585	568	289	325	953	385	1038	720	150
100-080-250	-	21,30	-	-	180M	125	305	348	174	350	246	863	402	180	280	290	325	493	605	638	295	370	988	385	1050	740	150

### Using PumpMeter

An accessories kit is required for using PumpMeter.  
Comprising:

- Pressure gauge connection (intermediate flange) 1.4571
- Hexagon head bolts: 8.8, ISO 4017
- Gasket: DPAF (asbestos-free), DIN 2690

As intermediate flanges need to be fitted, the dimensions differ.

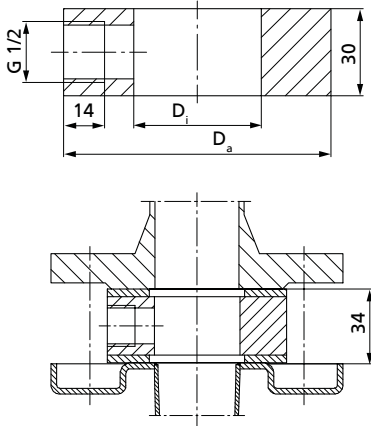

Fig. 16: Dimensions of the pressure gauge connection (intermediate flange) [mm]

Table 44: Selection table

DN	Pressure gauge connection		Hexagon head bolts	Gasket	Mat. No.
	D <sub>i</sub>	D <sub>a</sub>			
	[mm]				
25	29	70	4 × M12 × 80	1 × 25, PN 40	47064190
32	36	82	4 × M16 × 90	1 × 32, PN 40	47064192
40	44	92	4 × M16 × 90	1 × 40, PN 40	47064194
50	54	107	4 × M16 × 90	1 × 50, PN 40	47064196
65	69	127	4 × M16 × 90	1 × 65, PN 40	47064198
80	85	142	4 × M16 × 90	1 × 80, PN 40	47089653
100	105	162	4 × M16 × 90	1 × 100, PN 16	47089652

**Pump component weights**
**Weights of pump casing, discharge cover, intermediate piece and impeller**
**Table 45:** Selection table

Size	Pump casing (101)	Discharge cover (163)	Intermediate piece (132.1)	Impeller (230)
	[kg]			
050-025-125.1	3,0	0,3	-	0,9
050-025-125	3,0	0,3	-	0,9
050-025-160	3,3	0,6	-	1,2
050-025-200	4,2	0,8	-	1,8
050-025-250	6,2	1,5	12,4	5,5
050-032-125.1	3,1	0,3	-	0,9
050-032-125	3,1	0,3	-	0,9
050-032-160	3,4	0,6	-	1,2
050-032-200	4,3	0,8	-	1,8
050-032-250	6,3	1,5	12,4	5,5
065-040-125	3,6	0,3	-	0,9
065-040-160	4,1	0,6	-	1,2
065-040-200	4,7	0,8	-	1,8
065-040-250	6,6	1,5	12,4	5,1
065-050-125	4,6	0,6	-	1,0
065-050-160	4,6	0,7	-	1,6
065-050-200	6,9	1,1	8,7	4,9
065-050-250	7,2	1,5	12,4	6,6
080-065-200	7,8	1,5	12,4	5,6
080-065-250	8,1	1,5	12,7	7,8
100-080-200	9,9	1,5	12,7	7,5
100-080-250	10,2	1,5	12,7	9,6

**Shaft weight**
**Table 46:** Selection table

Motor size	Motor	P [kW]	Shaft (210)		
			WS 25.1	WS 25.2	WS 35
			[kg]		
.../072	80M	0,75	0,6	-	-
.../112	80M	1,1	0,6	-	-
.../152	90S	1,5	0,8	-	-
.../222	90L	2,2	0,8	-	-
.../302	100L	3,0	0,8	-	-
.../402	112M	4,0	0,8	-	-
.../552	132S	5,5	2,1	2,3	-
.../752	132S	7,5	2,1	2,3	-
.../1102	160M	11,0	2,1	2,4	2,8
.../1502	160M	15,0	2,1	2,4	2,8
.../1852	160L	18,5	2,1	2,4	2,8
.../2202	180M	22,0	-	2,2	2,2
.../3002	200L	30,0	-	2,8	3,8
.../3702	200L	37,0	-	2,8	3,8
.../4502	225M	45,0	-	-	3,8
.../054	80M	0,55	0,6	-	-
.../074	80M	0,75	0,6	0,9	-
.../114	90S	1,1	0,8	1,0	-
.../154	90L	1,5	0,8	1,0	-
.../224	100L	2,2	0,8	1,1	2,8
.../304	100L	3,0	0,8	1,1	2,8
.../404	112M	4,0	-	1,1	2,8
.../554	132S	5,5	-	2,3	2,8

Motor size	Motor	P [kW]	Shaft (210)		
			WS 25.1	WS 25.2	WS 35
			[kg]		
.../754	132M	7,5	-	2,3	2,8
.../1104	160M	11,0	-	2,4	2,8
.../1504	160L	15,0	-	-	2,8
.../1854	180M	18,5	-	-	2,2

**Drive lantern weight**
**Table 47: Selection table**

Size	Drive lantern (341)										
	.../072	.../054	.../302	.../224	.../552	.../554	.../1102	.../1104	.../2202	.../3002	.../4502
	.../112	.../074	.../402	.../304	.../752	.../754	.../1502			.../3702	
	.../152	.../114		.../404			.../1852				
	.../222	.../154									
	[kg]										
050-025-125.1	6,0		8,0		-		-	-	-	-	-
050-025-125	6,0		8,0		-		-	-	-	-	-
050-025-160	9,0		13,0		10,5		-	-	-	-	-
050-025-200	10,0		10,0		11,5		16,0	-	-	-	-
050-025-250	4,0		5,5		7,5		12,7	-	-	-	-
050-032-125.1	6,0		8,0		-		-	-	-	-	-
050-032-125	6,0		8,0		-		-	-	-	-	-
050-032-160	9,0		13,0		10,5		15,0	-	-	-	-
050-032-200	10,0		10,0		11,5		16,0	-	-	-	-
050-032-250	4,0		5,5		7,5		12,7	-	-	-	-
065-040-125	6,0		8,0		-		-	-	-	-	-
065-040-160	9,0		13,0		10,5		15,0	-	-	-	-
065-040-200	10,0		10,0		11,5		16,0	-	-	-	-
065-040-250	4,0		5,5		7,5		12,7	12,7	18,0	-	-
065-050-125	9,0		13,0		10,5		15,0	-	-	-	-
065-050-160	9,0		13,0		10,5		15,0	-	-	-	-
065-050-200	4,0		5,5		7,5		12,7	12,7	18,0	-	-
065-050-250	4,0		5,5		7,5		12,7	12,7	18,0	-	-
080-065-200	4,0		5,5		7,5		12,7	12,7	18,0	34,0	-
080-065-250	-		6,8		7,9		12,7	12,7	19,0	23,5	-
100-080-200	-		6,8		7,9		12,7	12,7	19,0	23,5	-
100-080-250	-		6,8		7,9		12,7	-	-	-	-

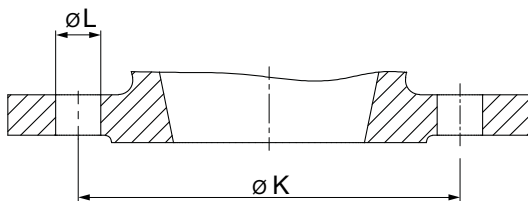
**Flange design (stainless steel to EN 1092-1)**

**Fig. 17: Flange (example)**
**Table 48: Flange dimensions [mm]**

Nominal size	PN 16 / 12 bar	
	ø K	Number and ø of holes (ø L)
25	85	4 x ø14
32	100	4 x ø18
40	110	4 x ø18
50	125	4 x ø18
65	145	4 x ø18
80	160	8 x ø18
100	180	8 x ø18

Installation types  
Horizontal installation

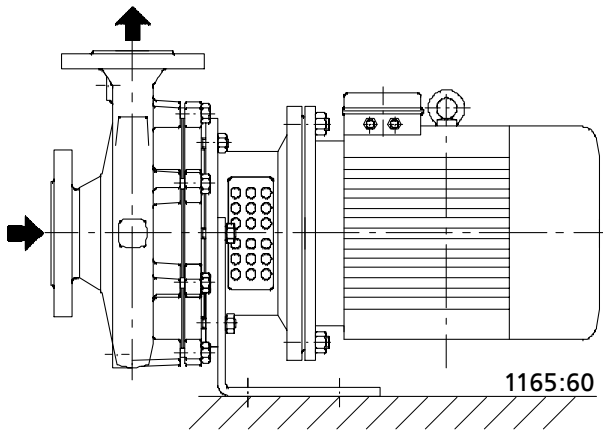

Fig. 18: Pump foot, fastened below, up to motor size 112 = 4 kW

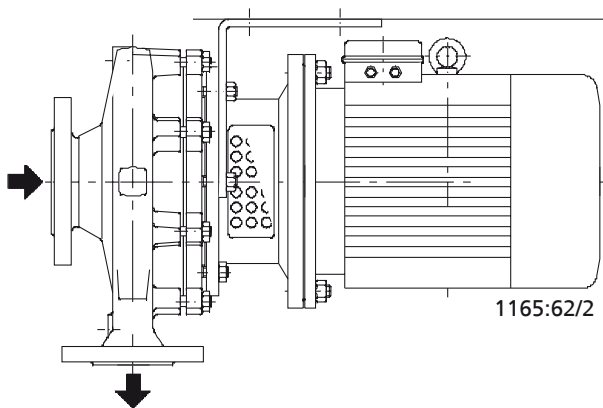

Fig. 19: Pump foot, fastened above, up to motor size 112 = 4 kW

The motor must be turned by 180°.

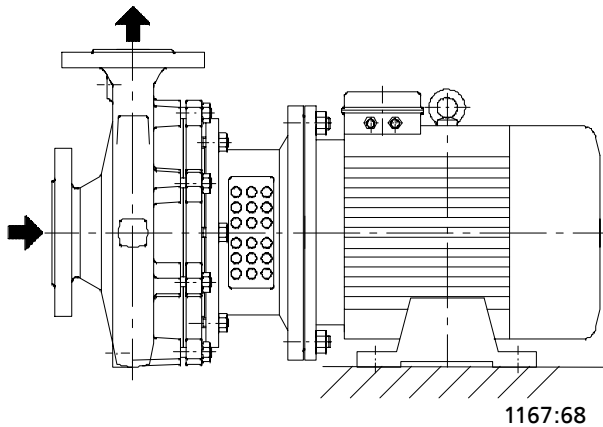

Fig. 20: Motor foot, fastened below, motor sizes 132 = 5.5 kW to 225 = 45 kW

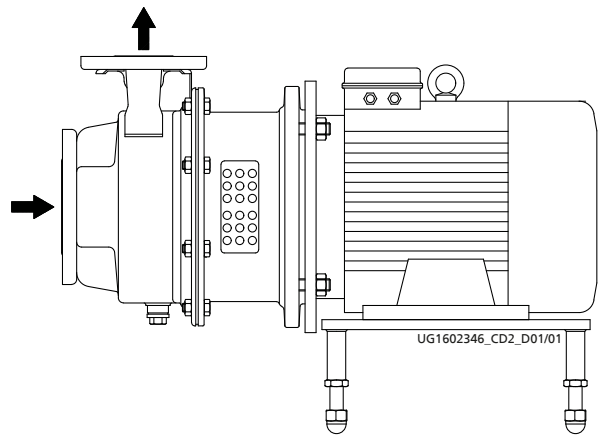

Fig. 21: Ball feet, motor sizes 80 = 0.55 kW to 225 = 45 kW

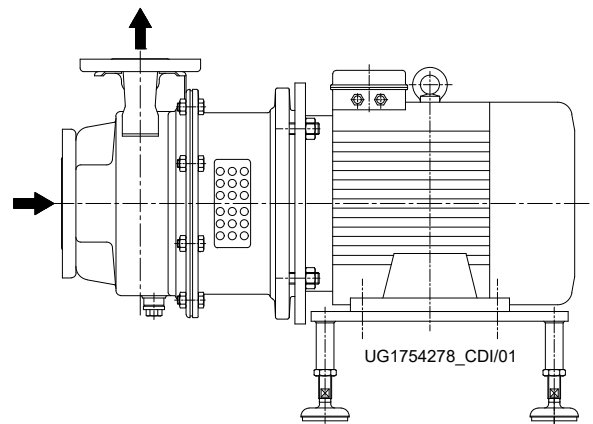

Fig. 22: Machine mount, motor sizes 80 = 0.55 kW to 225 = 45 kW

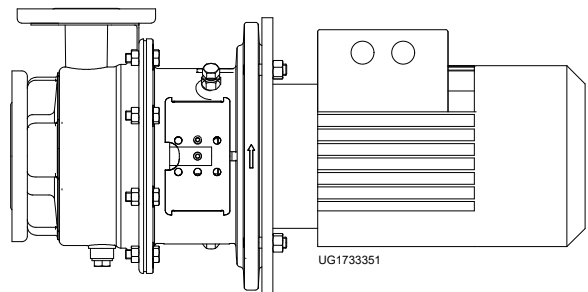
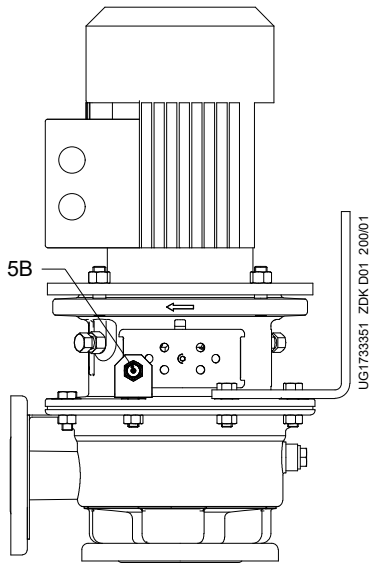

Fig. 23: Bottle rinsing variant, motor sizes 80 = 0.55 kW to 132 = 7.5 kW



**Vertical installation<sup>60)</sup>**

For vertical installation with the motor on top, use connection 5B for venting.



**Fig. 24:** Illustration of closing element with vent function

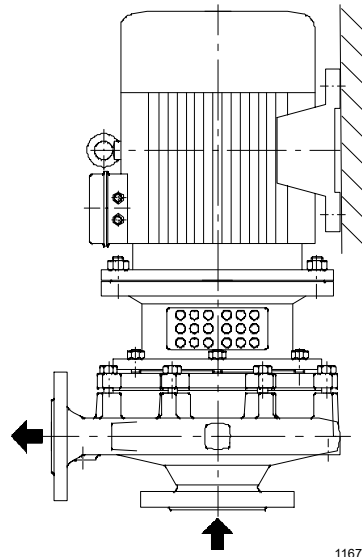

**Fig. 26:** Motor foot, fastened at the side, motor sizes 132 = 5.5 kW to 225 = 45 kW

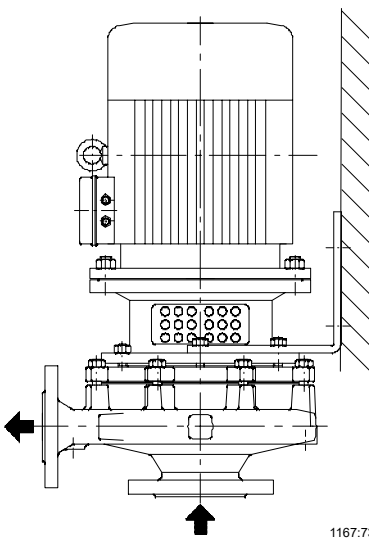

**Fig. 25:** Pump foot, fastened at the side, up to motor size 112 = 4 kW

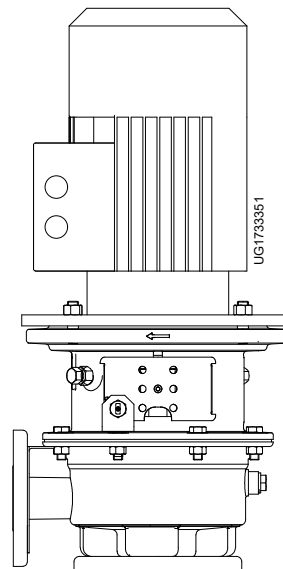

**Fig. 27:** Bottle rinsing variant, motor sizes 80 = 0.55 kW to 180 = 22 kW

<sup>60)</sup> A vent valve must be fitted to prevent dry running of the mechanical seal.

Interchangeability of Etachrom B and Etachrom L pump components

Table 49: Symbols key

Symbol	Description
*	Component interchangeable with Etachrom L; impellers must be of the same diameter
○	Components differ
✕	Component not fitted
□	Pump/motor combination not possible

Table 50: Etachrom B pump components<sup>61)</sup>

Size	Shaft unit	Pump casing				Shaft								Impeller	O-ring	Mechanical seal	Casing wear ring, suction side	Casing wear ring, discharge side	Shaft sleeve
		101	132.01	163	183	210													
						Motor													
						80	90	100/112	132	160	180	200/225							
050-025-125.1	WS 25.1	1	✕	1*	1	1	2	□	□	□	□	□	1*	1*	1*	1*	✕	✕	
050-025-125	WS 25.1	1	✕	1*	1	1	2	3	□	□	□	□	2*	1*	1*	1*	✕	✕	
050-025-160	WS 25.1	○	✕	5*	2	1	2	3	4	□	□	□	3*	2*	1*	1*	✕	✕	
050-025-200	WS 25.1	○	✕	2*	3	1	2	3	4	5	□	□	4*	3*	1*	1*	1*	✕	
050-025-250	WS 25.2	○	1*	3*	4	6	7	8	9	10	□	□	5*	4*	2*	6*	2*	✕	
050-032-125.1	WS 25.1	2	✕	1*	1	1	2	□	□	□	□	□	1*	1*	1*	1*	✕	✕	
050-032-125	WS 25.1	2	✕	1*	1	1	2	3	□	□	□	□	2*	1*	1*	1*	✕	✕	
050-032-160	WS 25.1	○	✕	5*	2	1	2	3	4	□	□	□	3*	2*	1*	1*	✕	✕	
050-032-200	WS 25.1	○	✕	2*	3	1	2	3	4	5	□	□	4*	3*	1*	1*	1*	✕	
050-032-250	WS 25.2	○	1*	3*	4	6	7	8	9	10	□	□	5*	4*	2*	6*	2*	✕	
065-040-125	WS 25.1	○	✕	1*	1	1	2	3	□	□	□	□	○*	1*	1*	2*	✕	✕	
065-040-160	WS 25.1	○	✕	○*	2	1	2	3	4	5	□	□	○*	2*	1*	2*	1*	✕	
065-040-200	WS 25.1	○	✕	2*	3	□	2	□	4	5	□	□	○*	3*	1*	2*	1*	✕	
065-040-250	WS 25.2	○	1*	3*	4	□	7	8	9	10	11	□	○*	4*	2*	3*	2*	✕	
065-050-125	WS 25.1	○	✕	○*	2	1	2	3	4	□	□	□	○*	2*	1*	2*	✕	✕	
065-050-160	WS 25.1	○	✕	○*	2	1	2	□	4	5	□	□	○*	2*	1*	2*	1*	✕	
065-050-200	WS 25.2	○	2*	○*	4	6	7	8	9	10	11	□	○*	5*	2*	3*	2*	✕	
065-050-250	WS 25.2	○	1*	3*	4	□	7	8	□	10	11	12	○*	4*	2*	3*	2*	✕	
080-065-200	WS 25.2	○	1*	○*	4	□	7	8	□	10	11	12	○*	4*	2*	4*	○*	✕	
080-065-250	WS 35	○	3*	4*	5	□	□	12	13	14	15	16	○*	4*	3*	4*	3*	1*	
100-080-200	WS 35	○	3*	4*	5	□	□	12	13	14	15	16	○*	4*	3*	5*	3*	1*	
100-080-250	WS 35	○	3*	4*	5	□	□	12	13	14	□	□	○*	4*	3*	5*	3*	1*	
<b>Drive lantern 341</b>																			
050-025-125.1	WS 25.1	-	-	-	-	1	1	□	□	□	□	□	-	-	-	-	-	-	
050-025-125	WS 25.1	-	-	-	-	1	1	2	□	□	□	□	-	-	-	-	-	-	
050-025-160	WS 25.1	-	-	-	-	3	3	4	5	□	□	□	-	-	-	-	-	-	
050-025-200	WS 25.1	-	-	-	-	7	7	8	9	10	□	□	-	-	-	-	-	-	
050-025-250	WS 25.2	-	-	-	-	11	11	12	13	14	□	□	-	-	-	-	-	-	
050-032-125.1	WS 25.1	-	-	-	-	1	1	□	□	□	□	□	-	-	-	-	-	-	
050-032-125	WS 25.1	-	-	-	-	1	1	2	□	□	□	□	-	-	-	-	-	-	

<sup>61</sup> Pump components featuring the same number in a column are interchangeable, i.e. same number = same component

<sup>62</sup> Up to motor size 112 = 4.0 kW only

Size	Shaft unit	Pump casing	Intermediate piece	Discharge cover	Pump foot <sup>62)</sup>	Shaft										Impeller	O-ring	Mechanical seal	Casing wear ring, suction side	Casing wear ring, discharge side	Shaft sleeve
						210															
						Motor															
						80	90	100/112	132	160	180	200/225									
050-032-160	WS 25.1	-	-	-	-	3	3	4	5	□	□	□	-	-	-	-	-	-			
050-032-200	WS 25.1	-	-	-	-	7	7	8	9	10	□	□	-	-	-	-	-	-			
050-032-250	WS 25.2	-	-	-	-	11	11	12	13	14	□	□	-	-	-	-	-	-			
065-040-125	WS 25.1	-	-	-	-	1	1	2	□	□	□	□	-	-	-	-	-	-			
065-040-160	WS 25.1	-	-	-	-	3	3	4	5	6	□	□	-	-	-	-	-	-			
065-040-200	WS 25.1	-	-	-	-	7	7	□	9	10	□	□	-	-	-	-	-	-			
065-040-250	WS 25.2	-	-	-	-	□	11	12	13	14	14	□	-	-	-	-	-	-			
065-050-125	WS 25.1	-	-	-	-	3	3	4	5	□	□	□	-	-	-	-	-	-			
065-050-160	WS 25.1	-	-	-	-	3	3	□	5	6	□	□	-	-	-	-	-	-			
065-050-200	WS 25.2	-	-	-	-	11	11	12	13	14	14	□	-	-	-	-	-	-			
065-050-250	WS 25.2	-	-	-	-	□	11	12	□	14	14	13	-	-	-	-	-	-			
080-065-200	WS 25.2	-	-	-	-	□	11	12	□	14	14	13	-	-	-	-	-	-			
080-065-250	WS 35	-	-	-	-	□	□	15	16	17	17	16	-	-	-	-	-	-			
100-080-200	WS 35	-	-	-	-	□	□	15	16	17	17	16	-	-	-	-	-	-			
100-080-250	WS 35	-	-	-	-	□	□	□	16	17	□	□	-	-	-	-	-	-			

Table 51: Motor rating

Motor	Rating
80	.../054, .../074, .../072, .../112
90	.../114, .../154, .../152, .../222
100	.../224, .../304, .../302
112	.../404, .../402
132	.../552, .../554, .../752, .../754
160	.../1102, .../1104, .../1502, .../1852
180	.../2202
200	.../3002, .../3702
225	.../4502

Recommended spare parts stock for 2 years' operation to DIN 24296

Table 52: Quantity of spare parts for recommended spare parts stock

Part No.	Description	Number of pumps (including stand-by pumps)						
		2	3	4	5	6 and 7	8 and 9	10 and more
210	Shaft	1	1	1	2	2	2	20 %
230	Impeller	1	1	1	2	2	2	20 %
412.35	O-ring	4	6	8	8	9	12	150 %
433	Mechanical seal	1	1	2	2	2	3	25 %
502.01 <sup>63)</sup>	Casing wear ring, suction side	2	2	2	3	3	4	50 %

<sup>63)</sup> Not for Etachrom B 065-050-125 with vortex impeller

Part No.	Description	Number of pumps (including stand-by pumps)						
		2	3	4	5	6 and 7	8 and 9	10 and more
502.02 <sup>64)</sup>	Casing wear ring, discharge side	2	2	2	3	3	4	50 %
502.06 <sup>65)</sup>	Casing wear ring, impeller	2	2	2	3	3	4	50 %
523 <sup>66)</sup>	Shaft sleeve	2	2	2	3	3	4	50 %
400.75 <sup>66)</sup>	Gasket	4	6	8	8	9	10	100 %

<sup>64)</sup> Not for Etachrom B 050-025-125.1, 050-025-125, 050-025-160, 050-032-125.1, 050-032-125, 050-032-160, 065-040-125, 065-050-125

<sup>65)</sup> Only for Etachrom B 080-065-250, 100-080-250

<sup>66)</sup> Only for Etachrom B 080-065-250, 100-080-200, 100-080-250

## Glossary

### ACS

French drinking water regulations (ACS = Attestation de Conformité Sanitaire)

### Back pull-out design

The complete back pull-out unit can be pulled out without having to remove the pump casing from the piping.

### Close-coupled design

Motor directly fitted to the pump via a flange or a drive lantern

### IE2

Efficiency class to IEC 60034-30: 2 = High Efficiency (IE = International Efficiency)

### IE3

Efficiency class to IEC 60034-30: 3 = Premium Efficiency (IE = International Efficiency)

### IE4

Efficiency class to IEC TS 60034-30-2:2016 = Super Premium Efficiency (IE = International Efficiency)

### IE5

Efficiency class to IEC TS 60034-30-2:2016 = Ultra Premium Efficiency (IE = International Efficiency)

### UBA

German drinking water regulations to German Environment Agency

### WRAS

Approved by all water suppliers in the UK (WRAS = Water Regulations Advisory Scheme)







**KSB SE & Co. KGaA**  
Johann-Klein-Straße 9 • 67227 Frankenthal (Germany)  
Tel. +49 6233 86-0  
[www.ksb.com](http://www.ksb.com)