

Synchronous Reluctance Motor

KSB SuPremE

Type Series Booklet



Legal information/Copyright

Type Series Booklet KSB SuPremE

All rights reserved. The contents provided herein must neither be distributed, copied, reproduced, edited or processed for any other purpose, nor otherwise transmitted, published or made available to a third party without the manufacturer's express written consent.

Subject to technical modification without prior notice.

© KSB SE & Co. KGaA, Frankenthal 2023-02-14

Contents

Drives	4
Synchronous Reluctance Motor.....	4
KSB SuPremE.....	4
Main applications.....	4
Design details.....	4
Bearings.....	4
Designation.....	6
Speed / frequency.....	7
Product benefits.....	7
Product information.....	7
Product information as per Regulation No. 1907/2006 (REACH).....	7
Noise characteristics.....	8
Versions.....	9
Versions with non-insulated bearings.....	9
Versions with insulated bearings.....	12
Technical data.....	13
Electrical data for all motors depending on rated power and rated speed.....	13
Power loss to DIN EN 50598-2:2015.....	15
Efficiency classes to IEC TS 60034-30-2:2016 and loss values to IEC TS 60034-2-3:2016.....	17
Dimensions.....	19
Motor with adapter and PumpDrive 2.....	19
Motor with terminal box.....	21
Key.....	22
Motor.....	23
Motor feet.....	23
Terminal box.....	24
Motor-mounted PumpDrive 2.....	24
Key.....	25
Motor flange.....	25
Mounting arrangements.....	26
Available torque.....	28
General arrangement drawings with list of components.....	29
Variant made of aluminium.....	29
Variant made of grey cast iron.....	30
Adapter, sizes A and B.....	31
Adapter, size C.....	32
Adapter, sizes D and E.....	33

Drives

Synchronous Reluctance Motor

KSB SuPremE

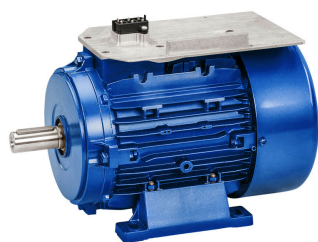
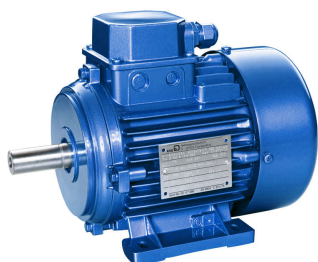

i The product illustrated as an example may include options incurring a surcharge.

Main applications

- Dry-installed pumps, in particular those that accumulate a high number of operating hours per year and have to accommodate fluctuating loads
- Rotating equipment

Design details

- Magnetless synchronous reluctance motor¹⁾
- Without rotor position sensors
- Rotor with air gaps (in accordance with US patent No. 5818140)

- Mounting points to EN 50347:2001
- Envelope dimensions to DIN VDE 42673-4:2011-07
- Self-cooling (design: TEFC)
- Shaft centreline height 71 to 225 mm
- Rated power 0.55 kW to 45 kW

Design

KSB SuPremE X1:

- With terminal box for connecting to PumpDrive 2 or PumpDrive R for mounting on walls and in control cabinets

KSB SuPremE X2:

- Equipped for being fitted with a motor-mounted PumpDrive 2

Connections

Flange type, designations to EN 50347:2001

Without flange:

- Type of construction IM B3 (standard), with foot, shaft centreline height 71 to 225 mm
- Type of construction IM B6/B7/B8/V5/V6, with foot, shaft centreline height 71 to 225 mm

Flange with clearance holes (FF):

- Type of construction IM V15 (standard), with foot, shaft centreline height 71 to 225 mm
- Type of construction IM V35 (not for special design for Movitec), with foot, shaft centreline height 71 to 225 mm
- Type of construction IM B35, with foot, shaft centreline height 71 to 225 mm
- Type of construction IM V1 (standard), without foot, shaft centreline height 71 to 225 mm
- Type of construction IM V3 (not for special design for Movitec), without foot, shaft centreline height 71 to 225 mm
- Type of construction IM B5, without foot, shaft centreline height 71 to 225 mm

Flange with tapped holes (FT), special design for Movitec:

- Type of construction IM V18 (standard), without foot, shaft centreline height ≤ 132 mm
- Type of construction IM B14/V19, without foot, shaft centreline height ≤ 132 mm

Bearings

Table 1: Non-insulated bearings used

Motor size	Generation	Type of construction B3 / V1 / V15		Special design Movitec	
		Drive end	Non-drive end	Drive end	Non-drive end
71M	B	E2.6203-2ZC3	E2.6203-2ZC3	E2.6203-2ZC3	E2.6203-2ZC3
71M	C	E2.6202-2ZC3	E2.6202-2ZC3	E2.6203-2ZC3	E2.6202-2ZC3
80M	B	E2.6204-2ZC3	E2.6204-2ZC3	E2.6204-2ZC3	E2.6204-2ZC3
80M	C	E2.6204-2ZC3	E2.6204-2ZC3	E2.6204-2ZC3	E2.6204-2ZC3
80M	D	E2.6204-2ZC3	E2.6204-2ZC3	-	-
90S/L	B	E2.6205-2ZC3	E2.6205-2ZC3	E2.6305-2ZC3	E2.6305-2ZC3
90S/L	C	E2.6205-2ZC3	E2.6205-2ZC3	E2.6305-2ZC3	E2.6205-2ZC3
100L	B	E2.6206-2ZC3	E2.6206-2ZC3	E2.6306-2ZC3	E2.6306-2ZC3
100L	C	E2.6206-2ZC3	E2.6206-2ZC3	E2.6306-2ZC3	E2.6206-2ZC3
100L	D	E2.6206-2ZC3	E2.6206-2ZC3	-	-
112M	B	E2.6306-2ZC3	E2.6306-2ZC3	E2.6306-2ZC3	E2.6306-2ZC3

¹ Exception: Motor sizes 0.55 kW / 0.75 kW with 1500 rpm are designed with permanent magnets.

Motor size	Generation	Type of construction B3 / V1 / V15		Special design Movitec	
		Drive end	Non-drive end	Drive end	Non-drive end
112M	C	E2.6206-2ZC3	E2.6206-2ZC3	E2.6306-2ZC3	E2.6206-2ZC3
112M	D	E2.6206-2ZC3	E2.6206-2ZC3	-	-
132M/S	B	E2.6308-2ZC3	E2.6308-2ZC3	E2.6308-2ZC3	E2.6308-2ZC3
132M/S	C	E2.6208-2ZC3	E2.6208-2ZC3	E2.6308-2ZC3	E2.6208-2ZC3
160M/L	B	E2.6309-2ZC3	E2.6309-2ZC3	7309	E2.6309-2ZC3
160M/L	C	E2.6309-2ZC3	E2.6309-2ZC3	7309	E2.6309-2ZC3
180M/L ²⁾	D	6210-J2ZC3	6210-J2ZC3	7310 BEP	6210-J2ZC3
200L ²⁾	D	6212-J2ZC3	6212-J2ZC3	7312 BEP	6212-J2ZC3
225S/M	D	6213-JZC3	6213-JZC3	7313 BEP	6213-JZC3

Table 2: Insulated bearings used

Motor size	Generation	Type of construction B3 / V1 / V15		Special design Movitec	
		Drive end	Non-drive end	Drive end	Non-drive end
180M/L	D	6210-JZC3	6210-2RS1 HC5 C3WT	7310 BEP	6210-2RS1 HC5 C3WT
200L	D	6212-JZC3	6212-2RS1 HC5 C3WT	7312 BEP	6212-2RS1 HC5 C3WT
225S/M	D	6213-JZC3	6213-JZC3 ³⁾	7313 BEP	6213-JZC3 ³⁾

² From serial number UC/UD 2111: changed from Z bearings to 2Z bearings

³ Insulated bearing seat (shaft)

Designation

Table 3: Designation example

Position																													
1	2	3	4	5	6	7	8	9	10	11	12	13	14	15	16	17	18	19	20	21	22	23	24	25	26	27	28	29	30
-	2	-	4	5	,	0	-	2	2	5	M	-	B	W	A	7	F	3	N	R	S	D	W	F	Z	W	K	S	F

Table 4: Designation key

Position	Code	Description
1-2	Nominal speed n [rpm]	
	2	3000
	4	1500
4-7	Motor rating P _N [kW]	
	0,55	0,55

	45,0	45,00
9-12	Motor size	
	71M	Shaft centreline height [mm]

	225M	Shaft centreline height [mm]
14	Enclosure	
	B	IP55 or IP40/55
15	Type of protection	
	W	Non-explosion-proof
16	Voltage	
	A / P	3~, AC, 220 VΔ, 380 VY, 50 Hz
17	Efficiency class	
	7	IE4 / IE5 (NEMA Super Premium / Ultra Premium)
18	Thermal class	
	F	Thermal class 155 (F)
19	Motor protection / winding protection	
	3	3 PTC thermistors
20	Direction of rotation	
	N	Clockwise / counter-clockwise (bi-directional)
21	Position of terminal box	
	T	Terminal box on top
	N	Not defined
	P	Adapter for PumpDrive 2 on top
22	Feet mounting	
	S	Feet attached by bolts
	W	Without feet
	H	Integrally cast feet
23	Position of fixed bearing	
	D	Fixed bearing, drive end
	C	Fixed bearing, drive end, reinforced
	F	Fixed bearing, drive end, axially reinforced
24	Protective roof	
	W	Without protective roof
25	Motor flange	
	F	EN 50347 Type FF
	T	EN 50347 Type FT
	A	EN 50347 Type FF, shaft without keyway
	B	EN 50347 Type FT, shaft without keyway
	W	Without flange
	C	Without flange, shaft without keyway
26	Operation on a frequency inverter	
	Z	Compulsory operation on a frequency inverter
27	Approval	
	W	Without approvals
28-30	Manufacturer	

Position	Code	Description
28-30	KSB	KSB SuPremE B, primed
	KSF	KSB SuPremE B, pearl gold, RAL 1036
	KSH	KSB SuPremE B, vermilion, RAL 2002
	KSH	KSB SuPremE B, ultramarine blue, RAL 5002
	SCD	KSB SuPremE C, pearl gold, RAL 1036
	SCD	KSB SuPremE C, ultramarine blue, RAL 5002
	SDB	KSB SuPremE D, pearl gold, RAL 1036
	SDD	KSB SuPremE D, ultramarine blue, RAL 5002

Speed / frequency

Table 5: Available speeds and frequencies

Generation	Rated speed	Maximum speed	Rated frequency	Maximum frequency
	[rpm]	[rpm]	[Hz]	[Hz]
B / C / D	1500	2100	50	70
D (0,55 kW / 0,75 kW)	1500	2100	125	175
B / C / D	3000	4200	100	140

Product benefits

- Energy-efficient operation thanks to high efficiency at the rated load point
- The efficiency of the motor also exceeds 95 % of the nominal efficiency when the motor runs at 25 % of its nominal power on a quadratic torque-speed curve.
- Fully interchangeable with IE2 motors thanks to compliance with DIN EN 50347 and envelope dimensions in accordance with DIN V 42673-4
- Low noise emissions and torque ripple due to use of rotor with air gaps (in accordance with US Patent No. 5818140)
- Sturdy design, no additional sensors
- Lower rotor temperature increases service life of bearings.
- Sustainable and environmentally friendly because no magnets based on "rare earth elements" such as NdFeB are used
- Compact variable speed drive when combined with motor-mounted PumpDrive 2 / PumpDrive 2 Eco

Product information

Product information as per Regulation No. 1907/2006 (REACH)

For information as per European chemicals regulation (EC) No. 1907/2006 (REACH) see <https://www.ksb.com/en-global/company/corporate-responsibility/reach>.

Noise characteristics
Table 6: Sound pressure level L_{pA}

Rated speed	Rated power	Motor size	Sound pressure level L_{pA} ⁴⁾
[rpm]	[kW]		[dB (A)]
1500	0,55	80M	60
1500	0,75	80M	60
1500	1,1	90S	60
1500	1,5	90L	60
1500	2,2	100L	60
1500	3	100L	60
1500	4	112M	61
1500	5,5	132S	61
1500	7,5	132M	61
1500	11	160M	61
1500	15	160L	61
1500	18,5	180M	63
1500	22	180L	63
1500	30	200L	64
1500	37	225S	64
1500	45	225M	64
3000	0,55	71M	70
3000	0,75	80M	70
3000	1,1	80M	70
3000	1,5	90S	70
3000	2,2	90L	70
3000	3	100L	71
3000	4	112M	71
3000	5,5	132S	71
3000	7,5	132S	71
3000	11	160M	71
3000	15	160M	71
3000	18,5	160L	72
3000	22	180M	72
3000	30	200L	72
3000	37	200L	72
3000	45	225M	72

⁴ Measured at idle with rated speed to IEC 60034-9

Versions

Versions with non-insulated bearings

i Motors of **types of construction IM B3, V1 and V15** are standard motor designs with a standardised shaft end (EN 50347) and standard bearings.

i Motors in **special design for Movitec** are fitted with the motor options required for the Movitec pump type series. They are designed with a plain shaft end and, depending on the size, with a flange or reinforced bearings.

Table 7: Selection table

Type of construction/ special design	Efficiency class	Rated speed [rpm]	Rated power [kW]	Motor	KSB SuPremE + terminal box		KSB SuPremE + mounting plate for PumpDrive 2 / PumpDrive 2 Eco		KSB SuPremE + PumpDrive 2	KSB SuPremE + PumpDrive 2 Eco
					Blue (RAL 5002)	Gold (RAL 1036)	Blue (RAL 5002)	Gold (RAL 1036)	Blue (RAL 5002)	Blue (RAL 5002)
					Mat. No.	Mat. No.	Mat. No.	Mat. No.	Mat. No.	Mat. No.
IM B3	IE5	1500	0,55 ⁵⁾	80M	05010022	05010006	05010025	05010009	01656802	01656918
IM B3	IE5	1500	0,75 ⁵⁾	80M	05010037	05010031	05010040	05010034	01656803	01656919
IM B3	IE5	1500	1,10	90S	01677993	01717350	01639914	01717478	01656804	01656920
IM B3	IE5	1500	1,50	90L	01677992	01717351	01639913	01717479	01656805	01656921
IM B3	IE5	1500	2,20	100L	01677991	01717352	01639912	01717480	01656806	01656922
IM B3	IE5	1500	3,00	100L	01677990	01717353	01639911	01717481	01656807	01656923
IM B3	IE5	1500	4,00	112M	01677989	01717354	01639910	01717482	01656808	01656924
IM B3	IE5	1500	5,50	132S	01677988	01717355	01639909	01717483	01656809	01656925
IM B3	IE5	1500	7,50	132M	01677987	01717356	01639908	01717484	01656810	01656926
IM B3	IE5	1500	11,00	160M	01677916	01717357	01639907	01717485	01656811	01656927
IM B3	IE5	1500	15,00	160L	01677915	01717358	01639906	01717486	01656812	- ⁶⁾
IM B3	IE4	1500	18,50	180M	01677914	01717359	01639905	01717487	01656813	- ⁶⁾
IM B3	IE4	1500	22,00	180L	01677913	01717360	01639904	01717488	01656814	- ⁶⁾
IM B3	IE4	1500	30,00	200L	01677912	01717361	01639903	01717489	01656815	- ⁶⁾
IM B3	IE4	1500	37,00	225S	01677911	01717362	01639902	01717490	01656816	- ⁶⁾
IM B3	IE4	1500	45,00	225M	01677910	01717363	01639901	01717491	01656817	- ⁶⁾
IM B3	IE5	3000	0,55	71M	01677902	01717364	01639900	01717492	01656818	01656928
IM B3	IE5	3000	0,75	80M	01677903	01717365	01639899	01717493	01656819	01656929
IM B3	IE5	3000	1,10	80M	01677904	01717366	01639898	01717494	01656820	01656930
IM B3	IE5	3000	1,50	90S	01677905	01717367	01639897	01717495	01656821	01656931
IM B3	IE5	3000	2,20	90L	01677906	01717368	01639896	01717496	01656822	01656932
IM B3	IE5	3000	3,00	100L	01677927	01717369	01639895	01717497	01656823	01656933
IM B3	IE5	3000	4,00	112M	01677928	01717370	01639894	01717498	01656824	01656934
IM B3	IE5	3000	5,50	132S	01677929	01717371	01639893	01717499	01656825	01656935
IM B3	IE5	3000	7,50	132S	01677930	01717372	01639892	01717500	01656826	01656936
IM B3	IE5	3000	11,00	160M	01677931	01717373	01639891	01717501	01656827	01656937
IM B3	IE5	3000	15,00	160M	01677932	01717374	01639890	01717502	01656828	- ⁶⁾
IM B3	IE5	3000	18,50	160L	01677933	01717375	01639889	01717503	01656829	- ⁶⁾
IM B3	IE4	3000	22,00	180M	01677934	01717376	01639888	01717504	01656830	- ⁶⁾
IM B3	IE4	3000	30,00	200L	01677935	01717377	01639887	01717505	01656831	- ⁶⁾
IM B3	IE4	3000	37,00	200L	01677936	01717378	01639886	01717506	01656832	- ⁶⁾
IM B3	IE4	3000	45,00	225M	01677937	01717379	01639885	01717507	01656833	- ⁶⁾
IM V1	IE5	1500	0,55 ⁵⁾	80M	05010023	05010007	05010026	05010020	01656834	01656938
IM V1	IE5	1500	0,75 ⁵⁾	80M	05010038	05010032	05010041	05010035	01656835	01656939
IM V1	IE5	1500	1,10	90S	01678008	01717382	01639818	01717510	01656836	01656940
IM V1	IE5	1500	1,50	90L	01678007	01717383	01639817	01717511	01656837	01656941
IM V1	IE5	1500	2,20	100L	01678006	01717384	01639816	01717512	01656838	01656942
IM V1	IE5	1500	3,00	100L	01678005	01717385	01639815	01717513	01656839	01656943
IM V1	IE5	1500	4,00	112M	01678004	01717386	01639814	01717514	01656840	01656944
IM V1	IE5	1500	5,50	132S	01678003	01717387	01639813	01717515	01656841	01656945

⁵ IE5 motors of sizes 0.55 kW / 0.75 kW with 1500 rpm are designed with permanent magnets; therefore a cogging torque is present when the motor is de-energised.

⁶ Not available

Type of construction/ special design	Efficiency class	Rated speed [rpm]	Rated power [kW]	Motor	KSB SuPremE + terminal box		KSB SuPremE + mounting plate for PumpDrive 2 / PumpDrive 2 Eco		KSB SuPremE + PumpDrive 2	KSB SuPremE + PumpDrive 2 Eco
					Blue (RAL 5002)	Gold (RAL 1036)	Blue (RAL 5002)	Gold (RAL 1036)	Blue (RAL 5002)	Blue (RAL 5002)
					Mat. No.	Mat. No.	Mat. No.	Mat. No.	Mat. No.	Mat. No.
IM V1	IE5	1500	7,50	132M	01678002	01717388	01639812	01717516	01656842	01656946
IM V1	IE5	1500	11,00	160M	01678001	01717389	01639811	01717517	01656843	01656947
IM V1	IE5	1500	15,00	160L	01678000	01717390	01639810	01717518	01656844	_) ⁶⁾
IM V1	IE4	1500	18,50	180M	01677999	01717391	01639809	01717519	01656845	_) ⁶⁾
IM V1	IE4	1500	22,00	180L	01677998	01717392	01639808	01717520	01656846	_) ⁶⁾
IM V1	IE4	1500	30,00	200L	01677997	01717393	01639807	01717521	01656847	_) ⁶⁾
IM V1	IE4	1500	37,00	225S	01677996	01717394	01639806	01717522	01656848	_) ⁶⁾
IM V1	IE4	1500	45,00	225M	01677995	01717395	01639805	01717523	01656849	_) ⁶⁾
IM V1	IE5	3000	0,55	71M	01677953	01717396	01639804	01717524	01656850	01656948
IM V1	IE5	3000	0,75	80M	01677952	01717397	01639803	01717525	01656851	01656949
IM V1	IE5	3000	1,10	80M	01677951	01717398	01639802	01717526	01656852	01656950
IM V1	IE5	3000	1,50	90S	01677950	01717399	01639801	01717527	01656853	01656951
IM V1	IE5	3000	2,20	90L	01677949	01717400	01639800	01717528	01656854	01656952
IM V1	IE5	3000	3,00	100L	01677948	01717401	01639799	01717529	01656855	01656953
IM V1	IE5	3000	4,00	112M	01677947	01717402	01639798	01717530	01656856	01656954
IM V1	IE5	3000	5,50	132S	01677946	01717403	01639797	01717531	01656857	01656955
IM V1	IE5	3000	7,50	132S	01677945	01717404	01639786	01717532	01656858	01656956
IM V1	IE5	3000	11,00	160M	01677944	01717405	01639785	01717533	01656859	01656957
IM V1	IE5	3000	15,00	160M	01677943	01717406	01639784	01717534	01656860	_) ⁶⁾
IM V1	IE5	3000	18,50	160L	01677942	01717407	01639783	01717535	01656861	_) ⁶⁾
IM V1	IE4	3000	22,00	180M	01677941	01717408	01639782	01717536	01656862	_) ⁶⁾
IM V1	IE4	3000	30,00	200L	01677940	01717409	01639781	01717537	01656863	_) ⁶⁾
IM V1	IE4	3000	37,00	200L	01677939	01717410	01639780	01717538	01656864	_) ⁶⁾
IM V1	IE4	3000	45,00	225M	01677938	01717411	01639779	01717539	01656865	_) ⁶⁾
IM V15	IE5	1500	0,55 ⁹⁾	80M	05010024	05010008	05010027	05010021	01656866	01656958
IM V15	IE5	1500	0,75 ⁹⁾	80M	05010039	05010033	05010042	05010036	01656867	01656959
IM V15	IE5	1500	1,10	90S	01678024	01717414	01639850	01717542	01656868	01656960
IM V15	IE5	1500	1,50	90L	01678023	01717415	01639849	01717543	01656869	01656961
IM V15	IE5	1500	2,20	100L	01678022	01717416	01639848	01717544	01656870	01656962
IM V15	IE5	1500	3,00	100L	01678021	01717417	01639847	01717545	01656871	01656963
IM V15	IE5	1500	4,00	112M	01678020	01717418	01639846	01717546	01656872	01656964
IM V15	IE5	1500	5,50	132S	01678019	01717419	01639845	01717547	01656873	01656965
IM V15	IE5	1500	7,50	132M	01678018	01717420	01639844	01717548	01656874	01656966
IM V15	IE5	1500	11,00	160M	01678017	01717421	01639843	01717549	01656875	01656967
IM V15	IE5	1500	15,00	160L	01678016	01717422	01639842	01717550	01656876	_) ⁶⁾
IM V15	IE4	1500	18,50	180M	01678015	01717423	01639841	01717551	01656877	_) ⁶⁾
IM V15	IE4	1500	22,00	180L	01678014	01717424	01639840	01717552	01656878	_) ⁶⁾
IM V15	IE4	1500	30,00	200L	01678013	01717425	01639839	01717553	01656879	_) ⁶⁾
IM V15	IE4	1500	37,00	225S	01678012	01717426	01639838	01717554	01656880	_) ⁶⁾
IM V15	IE4	1500	45,00	225M	01678011	01717427	01639837	01717555	01656881	_) ⁶⁾
IM V15	IE5	3000	0,55	71M	01677964	01717428	01639836	01717556	01656882	01656968
IM V15	IE5	3000	0,75	80M	01677963	01717429	01639835	01717557	01656883	01656969
IM V15	IE5	3000	1,10	80M	01677962	01717430	01639834	01717558	01656884	01656970
IM V15	IE5	3000	1,50	90S	01677961	01717431	01639833	01717559	01656885	01656971
IM V15	IE5	3000	2,20	90L	01677960	01717432	01639832	01717560	01656886	01656972
IM V15	IE5	3000	3,00	100L	01677959	01717433	01639831	01717561	01656887	01656973
IM V15	IE5	3000	4,00	112M	01677958	01717434	01639830	01717562	01656888	01656974
IM V15	IE5	3000	5,50	132S	01677957	01717435	01639829	01717563	01656889	01656975
IM V15	IE5	3000	7,50	132S	01677926	01717436	01639828	01717564	01656890	01656976
IM V15	IE5	3000	11,00	160M	01677925	01717437	01639827	01717565	01656891	01656977
IM V15	IE5	3000	15,00	160M	01677924	01717438	01639826	01717566	01656892	_) ⁶⁾
IM V15	IE5	3000	18,50	160L	01677923	01717439	01639825	01717567	01656893	_) ⁶⁾
IM V15	IE4	3000	22,00	180M	01677922	01717440	01639824	01717568	01656894	_) ⁶⁾

Type of construction/ special design	Efficiency class	Rated speed [rpm]	Rated power [kW]	Motor	KSB SuPremE + terminal box		KSB SuPremE + mounting plate for PumpDrive 2 / PumpDrive 2 Eco		KSB SuPremE + PumpDrive 2	KSB SuPremE + PumpDrive 2 Eco
					Blue (RAL 5002)	Gold (RAL 1036)	Blue (RAL 5002)	Gold (RAL 1036)	Blue (RAL 5002)	Blue (RAL 5002)
					Mat. No.	Mat. No.	Mat. No.	Mat. No.	Mat. No.	Mat. No.
IM V15	IE4	3000	30,00	200L	01677921	01717441	01639823	01717569	01656895	- ⁶⁾
IM V15	IE4	3000	37,00	200L	01677920	01717442	01639822	01717570	01656896	- ⁶⁾
IM V15	IE4	3000	45,00	225M	01677919	01717443	01639821	01717571	01656897	- ⁶⁾
Movitec	IE5	3000	0,55	71M	01677892	01717341	01639859	01717469	01656786	01656908
Movitec	IE5	3000	0,75	80M	01677891	01717342	01639858	01717470	01656787	01656909
Movitec	IE5	3000	1,10	80M	01677890	01717343	01639857	01717471	01656788	01656910
Movitec	IE5	3000	1,50	90S	01677889	01717344	01639856	01717472	01656789	01656911
Movitec	IE5	3000	2,20	90L	01677888	01717345	01639855	01717473	01656790	01656912
Movitec	IE5	3000	3,00	100L	01677887	01717346	01639854	01717474	01656791	01656913
Movitec	IE5	3000	4,00	112M	01677766	01717347	01639853	01717475	01656792	01656914
Movitec	IE5	3000	5,50	132S	01677894	01717332	01639868	01717460	01656793	01656915
Movitec	IE5	3000	7,50	132S	01677893	01717333	01639867	01717461	01656794	01656916
Movitec	IE5	3000	11,00	160M	01677901	01717323	01639877	01717451	01656795	01656917
Movitec	IE5	3000	15,00	160M	01677900	01717324	01639876	01717452	01656796	- ⁶⁾
Movitec	IE5	3000	18,50	160L	01677899	01717325	01639875	01717453	01656797	- ⁶⁾
Movitec	IE4	3000	22,00	180M	01677898	01717326	01639874	01717454	01656798	- ⁶⁾
Movitec	IE4	3000	30,00	200L	01677897	01717327	01639873	01717455	01656799	- ⁶⁾
Movitec	IE4	3000	37,00	200L	01677896	01717328	01639872	01717456	01656800	- ⁶⁾
Movitec	IE4	3000	45,00	225M	01677895	01717329	01639871	01717457	01656801	- ⁶⁾

Versions with insulated bearings

i Motors of **types of construction IM B3, V1 and V15** are standard motor designs with a standardised shaft end (EN 50347) and standard bearings.

i Motors in **special design for Movitec** are fitted with the motor options required for the Movitec pump type series. They are designed with a plain shaft end and, depending on the size, with a flange or reinforced bearings.

Table 8: Selection table

Type of construction/ special design	Efficiency class	Rated speed [rpm]	Rated power [kW]	Motor	KSB SuPremE + terminal box		KSB SuPremE + mounting plate for PumpDrive 2 / PumpDrive 2 Eco		KSB SuPremE + PumpDrive 2	KSB SuPremE + PumpDrive 2 Eco
					Blue (RAL 5002)	Gold (RAL 1036)	Blue (RAL 5002)	Gold (RAL 1036)	Blue (RAL 5002)	Blue (RAL 5002)
					Mat. No.	Mat. No.	Mat. No.	Mat. No.	Mat. No.	Mat. No.
IM B3	IE4	1500	18,50	180M	05108221	05108254	05108318	05108321	⁷⁾	⁷⁾
IM B3	IE4	1500	22,00	180L	05108220	05108255	05108317	05108322	⁷⁾	⁷⁾
IM B3	IE4	1500	30,00	200L	05108089	05108256	05108316	05108323	⁷⁾	⁷⁾
IM B3	IE4	1500	37,00	225S	05108088	05108257	05108315	05108324	⁷⁾	⁷⁾
IM B3	IE4	1500	45,00	225M	05108087	05108258	05108314	05108325	⁷⁾	⁷⁾
IM B3	IE4	3000	22,00	180M	05108226	05108259	05108313	05108326	⁷⁾	⁷⁾
IM B3	IE4	3000	30,00	200L	05108227	05108260	05108312	05108327	⁷⁾	⁷⁾
IM B3	IE4	3000	37,00	200L	05108228	05108261	05108311	05108328	⁷⁾	⁷⁾
IM B3	IE4	3000	45,00	225M	05108229	05108262	05108310	05108329	⁷⁾	⁷⁾
IM V1	IE4	1500	18,50	180M	05108243	05108263	05108291	05108330	⁷⁾	⁷⁾
IM V1	IE4	1500	22,00	180L	05108242	05108264	05108290	05108331	⁷⁾	⁷⁾
IM V1	IE4	1500	30,00	200L	05108241	05108265	05108079	05108332	⁷⁾	⁷⁾
IM V1	IE4	1500	37,00	225S	05108240	05108266	05108078	05108333	⁷⁾	⁷⁾
IM V1	IE4	1500	45,00	225M	05108239	05108267	05108077	05108334	⁷⁾	⁷⁾
IM V1	IE4	3000	22,00	180M	05108233	05108268	05108076	05108335	⁷⁾	⁷⁾
IM V1	IE4	3000	30,00	200L	05108232	05108269	05108075	05108336	⁷⁾	⁷⁾
IM V1	IE4	3000	37,00	200L	05108231	05108270	05108074	05108337	⁷⁾	⁷⁾
IM V1	IE4	3000	45,00	225M	05108230	05108271	05108073	05108338	⁷⁾	⁷⁾
IM V15	IE4	1500	18,50	180M	05108248	05108272	05108300	05108339	⁷⁾	⁷⁾
IM V15	IE4	1500	22,00	180L	05108247	05108273	05108299	05108340	⁷⁾	⁷⁾
IM V15	IE4	1500	30,00	200L	05108246	05108274	05108298	05108341	⁷⁾	⁷⁾
IM V15	IE4	1500	37,00	225S	05108245	05108275	05108297	05108342	⁷⁾	⁷⁾
IM V15	IE4	1500	45,00	225M	05108244	05108276	05108296	05108343	⁷⁾	⁷⁾
IM V15	IE4	3000	22,00	180M	05108225	05108277	05108295	05108344	⁷⁾	⁷⁾
IM V15	IE4	3000	30,00	200L	05108224	05108278	05108294	05108345	⁷⁾	⁷⁾
IM V15	IE4	3000	37,00	200L	05108223	05108279	05108293	05108346	⁷⁾	⁷⁾
IM V15	IE4	3000	45,00	225M	05108222	05108280	05108292	05108347	⁷⁾	⁷⁾
Movitec	IE4	1500	18,50	180M	05108238	05108215	05108309	05108202	⁷⁾	⁷⁾
Movitec	IE4	1500	22,00	180L	05108237	05108216	05108308	05108203	⁷⁾	⁷⁾
Movitec	IE4	1500	30,00	200L	05108236	05108217	05108307	05108204	⁷⁾	⁷⁾
Movitec	IE4	1500	37,00	225S	05108235	05108218	05108306	05108205	⁷⁾	⁷⁾
Movitec	IE4	1500	45,00	225M	05108234	05108219	05108305	05108206	⁷⁾	⁷⁾
Movitec	IE4	3000	22,00	180M	05108086	05108250	05108304	05108207	⁷⁾	⁷⁾
Movitec	IE4	3000	30,00	200L	05108085	05108251	05108303	05108208	⁷⁾	⁷⁾
Movitec	IE4	3000	37,00	200L	05108084	05108252	05108302	05108209	⁷⁾	⁷⁾
Movitec	IE4	3000	45,00	225M	05108083	05108253	05108301	05108320	⁷⁾	⁷⁾

⁷⁾ Not available

Technical data
Electrical data for all motors depending on rated power and rated speed
Table 9: Technical data

Characteristic		Value
Ambient temperature		-20 °C to +40 °C
Atmospheric humidity		Maximum of 55 % relative atmospheric humidity at 40 °C ambient temperature
Altitude		≤ 1000 m (without power derating)
Thermal class		F
Starting torque in [%] of rated torque		
	IC 411 continuous	50 %
	IC 416 continuous	100 %
	IC 411/416, 10 seconds max.	110 %
Maximum torque in [%] of rated torque		110 %
Enclosure		
	KSB SuPremE with terminal box	IP55
	KSB SuPremE with adapter plate for PumpDrive 2	IP55 ⁸⁾
Paint coat		RAL 5002, RAL 1036 or, if combined with a pump, in the same colour as the pump.

Table 10: Electrical data for all motors depending on rated power and rated speed

Rated speed	Rated power	Motor	Generation	Rated voltage	Rated current	Rated torque	Power factor at rated operating point $\cos \varphi^{(9)}$	Moment of inertia of rotor	Weight	Size PumpDrive 2 Eco
[rpm]	[kW]	-	-	[V]	[A]	[Nm]	-	[kgm ²]	[kg]	-
1500	0,55	80M	B/C	350	1,6	3,5	0,67	0,0015	11	A
1500	0,55	80M	D ¹⁰⁾	350	1,3	3,5	0,79	0,0011	8,5	A
1500	0,75	80M	B/C	355	2,1	4,8	0,68	0,0018	13	A
1500	0,75	80M	D ¹⁰⁾	300	2,0	4,8	0,80	0,0014	11,7	A
1500	1,1	90S	B/C	360	3,0	7,0	0,67	0,0019	15	A
1500	1,5	90L	B/C	365	4,0	9,5	0,67	0,0024	18	A
1500	2,2	100L	B/C	365	5,7	14,0	0,68	0,004	25	B
1500	2,2	100L	D	340	5,9	14,0	0,69	0,0053	26	B
1500	3	100L	B/C	355	7,8	19,1	0,69	0,0046	30	B
1500	3	100L	D	360	7,3	19,1	0,73	0,0051	27	B
1500	4	112M	B/C	360	9,6	25,5	0,73	0,0075	37	B
1500	4	112M	D	360	9,6	25,5	0,72	0,0086	36	B
1500	5,5	132S	B/C	350	13,5	35,0	0,73	0,018	45	C
1500	7,5	132M	B/C	355	17,6	47,7	0,75	0,026	60	C
1500	11	160M	B/C	365	24,2	70,0	0,77	0,051	81	C
1500	15	160L	B/C	355	33,1	95,5	0,78	0,063	107	D
1500	18,5	180M	B	350	42,2	117,8	0,77	0,12	151	D
1500	18,5	180M	C	380	42,0	117,8	0,71	0,12	189	D
1500	22	180L	B	365	48,5	140,1	0,76	0,14	175	D
1500	22	180L	C	380	50,0	140,1	0,71	0,13	203	D
1500	30	200L	B	365	65,4	191,0	0,76	0,21	239	D
1500	30	200L	C	380	68,0	191,0	0,71	0,19	246	D
1500	37	225S	B	360	80,9	235,5	0,77	0,34	348	E
1500	37	225S	C	380	81,0	235,5	0,73	0,48	337	E
1500	37	225S	D	380	79,0	236,0	0,75	0,442	340	E
1500	45	225M	B	360	99,3	286,5	0,76	0,38	396	E
1500	45	225M	C	380	98,0	286,5	0,73	0,48	347	E
1500	45	225M	D	380	96,0	286,0	0,75	0,518	343	E

⁸ With motor-mounted PumpDrive 2

⁹ No effect on power supply network

¹⁰ Permanent magnet motor

Rated speed	Rated power	Motor	Generation	Rated voltage	Rated current	Rated torque	Power factor at rated operating point $\cos \varphi^0$	Moment of inertia of rotor	Weight	Size PompeDrive 2 Eco
[rpm]	[kW]	-	-	[V]	[A]	[Nm]	-	[kgm ²]	[kg]	-
3000	0,55	71M	B/C	350	1,6	1,8	0,68	0,0004	9	A
3000	0,75	80M	B/C	360	2,1	2,4	0,67	0,0013	10	A
3000	1,1	80M	B/C	360	3,0	3,5	0,68	0,0016	12	A
3000	1,5	90S	B/C	380	4,1	4,8	0,63	0,017	15	A
3000	2,2	90L	B/C	360	5,6	7,0	0,71	0,0025	18	B
3000	3	100L	B/C	360	7,6	9,5	0,70	0,0043	24	B
3000	4	112M	B/C	355	9,4	12,7	0,76	0,0067	35	B
3000	5,5	132S	B/C	365	12,5	17,5	0,76	0,015	43	C
3000	7,5	132S	B/C	370	16,7	23,9	0,76	0,018	56	C
3000	11	160M	B/C	375	23,7	35,0	0,77	0,042	73	C
3000	15	160M	B/C	365	32,0	47,7	0,79	0,051	82	D
3000	18,5	160L	B/C	370	38,8	58,9	0,79	0,063	102	D
3000	22	180M	B	355	50,7	70,0	0,75	0,12	157	D
3000	22	180M	C	380	50,0	70,0	0,71	0,09	167	D
3000	30	200L	B	365	63,5	95,5	0,79	0,19	222	D
3000	30	200L	C	380	67,0	95,5	0,72	0,17	212	D
3000	37	200L	B	360	77,8	117,8	0,80	0,21	257	E
3000	37	200L	C	380	82,0	117,8	0,72	0,19	257	E
3000	45	225M	B	360	97,0	143,2	0,78	0,34	396	E
3000	45	225M	C	380	100,0	143,2	0,72	0,36	330	E
3000	45	225M	D	380	99,0	143,0	0,73	0,356	305	E

Power loss to DIN EN 50598-2:2015

The loss values indicated apply to the power drive system (PDS) consisting of a KSB SuPremE motor and a KSB PumpDrive 2 / PumpDrive 2 Eco frequency inverter with the same rated power.

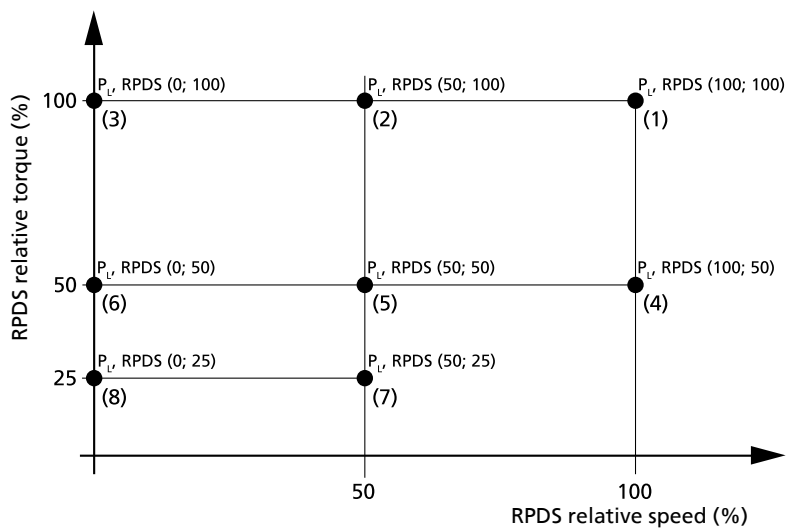

Fig. 1: Reference points to DIN EN 50598-2:2015

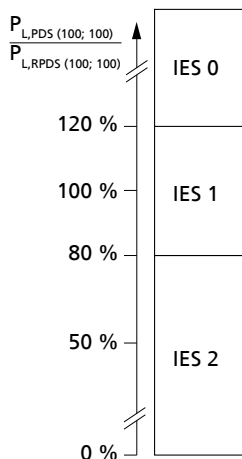

Fig. 2: Illustration of IES classes for a PDS to DIN EN 50598-2:2015

Table 11: Values for the reference points P_L , defined in DIN EN 50598-2:2015, RPDS (1) to (8)

P_N [kW]	n [rpm]	IES class	P_L^{11} [%]	P_L compared to the rated power [%]							
				Reference points							
				1	2	3	4	5	6	7	8
0,55	1500	IES2	43	26,3	23,2	19,7	16,4	14,1	11,3	9,8	7,7
0,55 ¹²⁾	1500	IES2	31	19,3	17,4	21,6	9,7	8,3	11,7	5,8	9,6
0,75	1500	IES2	42	21,6	21,7	19,6	15,7	14,1	11,8	11,6	9,3
0,75 ¹²⁾	1500	IES2	30	15,4	13,3	17,0	7,8	7,4	19,5	5,3	7,2
1,1	1500	IES2	41	18,1	15,0	14,2	10,0	8,2	7,4	5,0	4,8
1,5	1500	IES2	41	15,9	14,5	14,2	8,8	7,5	7,3	4,7	4,5
2,2	1500	IES2	39	13,4	11,7	10,7	7,9	6,6	6,1	4,0	3,7
3,0	1500	IES2	44	13,9	12,3	10,6	7,5	6,2	6,3	4,0	3,5
4,0	1500	IES2	42	12,1	11,0	10,0	6,6	5,6	5,0	3,5	2,6
5,5	1500	IES2	46	12,1	10,8	9,0	6,7	5,4	4,3	2,9	2,3
7,5	1500	IES2	45	10,9	9,0	8,3	5,3	4,5	3,8	2,4	2,1
11	1500	IES2	47	10,1	8,5	6,4	5,2	3,7	3,2	2,1	1,9
15	1500	IES2	45	9,0	7,1	5,4	4,1	3,6	2,9	1,5	1,8
18,5	1500	IES2	46	8,6	6,7	4,8	4,6	3,4	2,8	2,3	1,7

¹¹ Compared to reference PDS P_L , RPDS (100;100)

¹² IE5 motor

P _N	n	IES class	P _L ⁽¹⁾	P _L compared to the rated power [%]							
				Reference points							
[kW]	[rpm]		[%]	1	2	3	4	5	6	7	8
22	1500	IES2	46	8,3	6,1	4,6	4,3	3,3	2,6	2,1	1,6
30	1500	IES2	47	7,9	6,4	5,0	4,4	3,5	2,6	2,2	3,1
37	1500	IES2	48	7,7	5,9	4,7	4,0	3,1	2,5	1,9	2,1
45	1500	IES2	49	7,5	5,8	4,5	3,9	3,0	2,6	1,8	1,6
0,55	3000	IES2	38	23,5	17,6	16,9	15,5	11,5	10,4	8,1	7,5
0,75	3000	IES2	41	21,2	15,3	13,1	15,1	11,5	9,3	9,8	6,9
1,1	3000	IES2	45	19,8	14,5	12,7	13,1	9,3	7,6	6,5	5,2
1,5	3000	IES2	39	15,4	11,8	10,6	10,0	7,3	6,1	5,4	4,0
2,2	3000	IES2	37	12,7	9,7	8,2	7,9	5,7	4,6	3,7	3,1
3,0	3000	IES2	35	11,2	8,6	7,6	7,0	4,8	7,7	3,1	2,7
4,0	3000	IES2	45	12,9	10,1	6,9	9,4	6,0	4,0	4,9	2,5
5,5	3000	IES2	42	11,1	7,7	6,2	6,7	4,3	3,5	2,9	1,9
7,5	3000	IES2	49	11,7	7,4	6,3	7,0	4,2	3,2	2,8	1,5
11	3000	IES2	44	9,6	5,8	4,6	5,0	3,5	2,5	1,7	1,4
15	3000	IES2	52	10,4	6,5	3,8	6,1	3,9	2,1	2,6	1,3
18,5	3000	IES2	41	7,7	4,6	3,2	5,1	2,8	2,0	2,0	1,3
22	3000	IES2	46	8,4	5,5	4,0	5,3	3,4	2,5	2,4	1,3
30	3000	IES2	49	8,3	5,6	4,0	5,0	3,3	2,3	2,4	2,9
37	3000	IES2	45	7,3	5,1	3,4	4,8	3,0	2,0	2,0	1,9
45	3000	IES2	52	8,0	4,9	3,5	4,8	2,9	2,1	1,9	1,3

Efficiency classes to IEC TS 60034-30-2:2016 and loss values to IEC TS 60034-2-3:2016

The motor losses indicated apply to operation on a KSB PumpDrive 2 / PumpDrive 2 Eco frequency inverter with the same rated power.

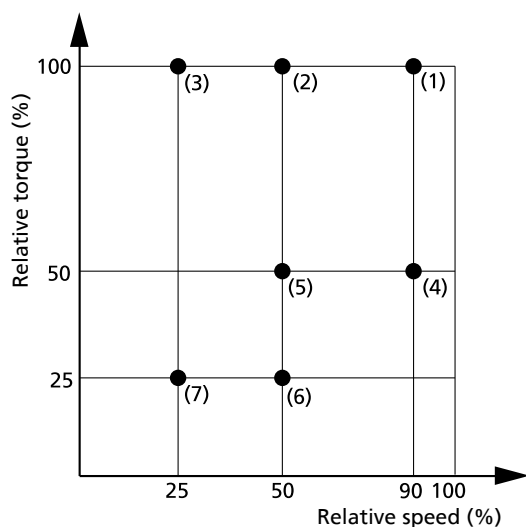

Fig. 3: Reference points to IEC TS 60034-2-3:2016

Table 12: Classification and loss values for reference points (1) to (7)

P _N [kW]	n [rpm]	Efficiency class	Motor losses [W]						
			Reference points						
			1	2	3	4	5	6	7
0,55	1500	IE4	109	96	58	57	51	33	15
0,55	1500	IE5 ¹³⁾	87	66	60	28	20	11	7
0,75	1500	IE4	130	128	114	82	72	59	50
0,75	1500	IE5 ¹³⁾	104	67	61	32	23	12	8
1,1	1500	IE5	134	126	120	68	57	29	26
1,5	1500	IE5	165	164	161	84	73	36	34
2,2	1500	IE5	215	185	165	111	91	48	40
3,0	1500	IE5	267	263	243	141	117	65	56
4,0	1500	IE5	322	317	298	173	149	82	71
5,5	1500	IE5	401	430	349	196	196	83	75
7,5	1500	IE5	492	464	417	226	197	83	80
11	1500	IE5	654	565	467	270	173	92	47
15	1500	IE5	801	589	524	320	241	63	122
18,5	1500	IE4	1177	834	712	513	374	225	187
22	1500	IE4	1331	899	735	599	453	265	178
30	1500	IE4	1662	1296	1086	837	642	364	268
37	1500	IE4	1938	1583	1198	928	690	382	294
45	1500	IE4	2267	1602	1326	1008	745	402	323
0,55	3000	IE5	104	66	54	52	37	24	16
0,75	3000	IE5	123	81	72	78	54	45	32
1,1	3000	IE5	158	120	100	96	69	45	32
1,5	3000	IE5	195	124	107	96	70	48	29
2,2	3000	IE5	247	142	119	101	72	40	30
3,0	3000	IE5	303	149	130	110	73	37	29
4,0	3000	IE5	369	280	205	257	166	137	90
5,5	3000	IE5	454	261	196	227	136	82	14
7,5	3000	IE5	555	346	270	305	179	108	64
11	3000	IE5	722	284	285	396	153	56	58
15	3000	IE5	908	477	302	534	276	213	51
18,5	3000	IE5	1025	456	312	543	276	186	99
22	3000	IE4	1445	771	598	735	480	330	191

¹³ IE5 motors of sizes 0.55 kW / 0.75 kW with 1500 rpm are designed with permanent magnets; therefore a cogging torque is present when the motor is de-energised.

P _N	n	Efficiency class	Motor losses [W]						
			Reference points						
[kW]	[rpm]		1	2	3	4	5	6	7
30	3000	IE4	1815	1036	803	946	577	425	230
37	3000	IE4	2088	1144	820	1130	654	448	299
45	3000	IE4	2448	1216	880	1289	698	449	255

Dimensions

Motor with adapter and PumpDrive 2

Motor size 112 fitted with an additional adapter between motor housing and adapter plate for PumpDrive 2.

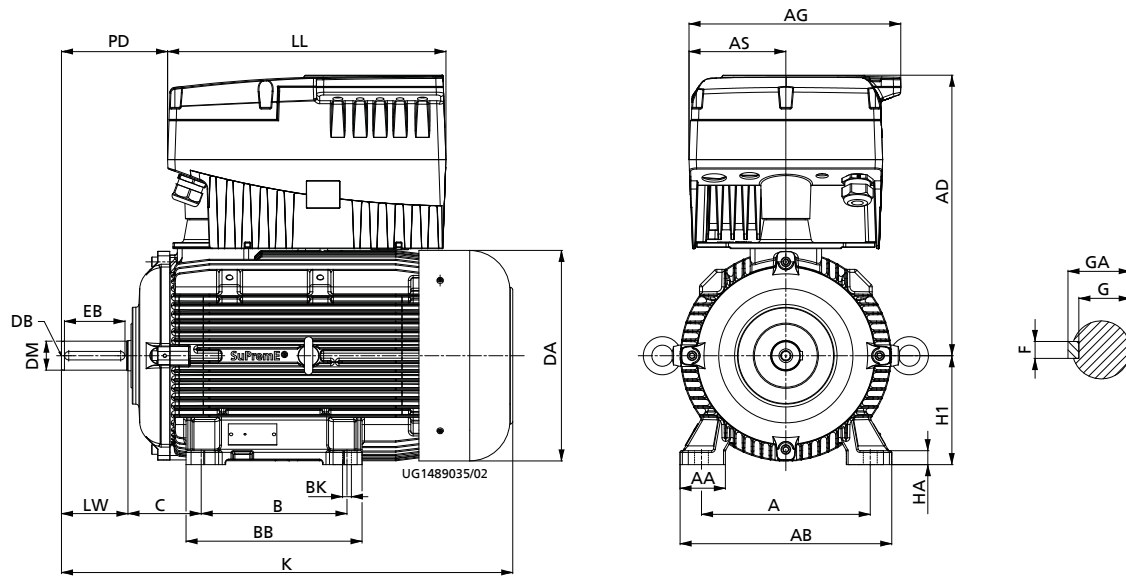

Fig. 4: Version with standard bearing cover (B3, etc.)

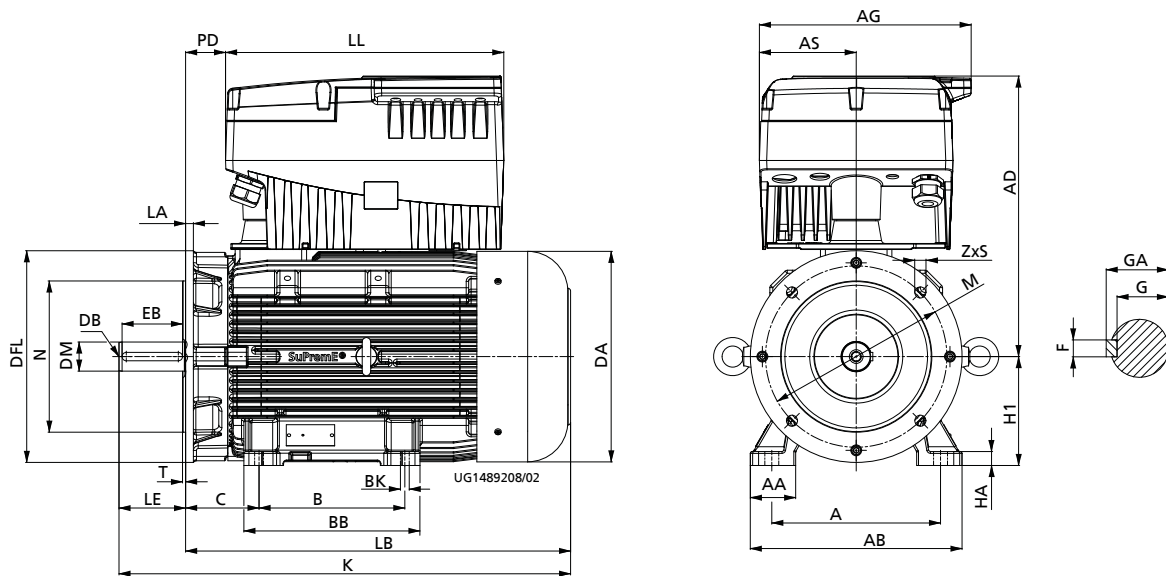

Fig. 5: Version with FF flange with clearance holes (V15, etc.)

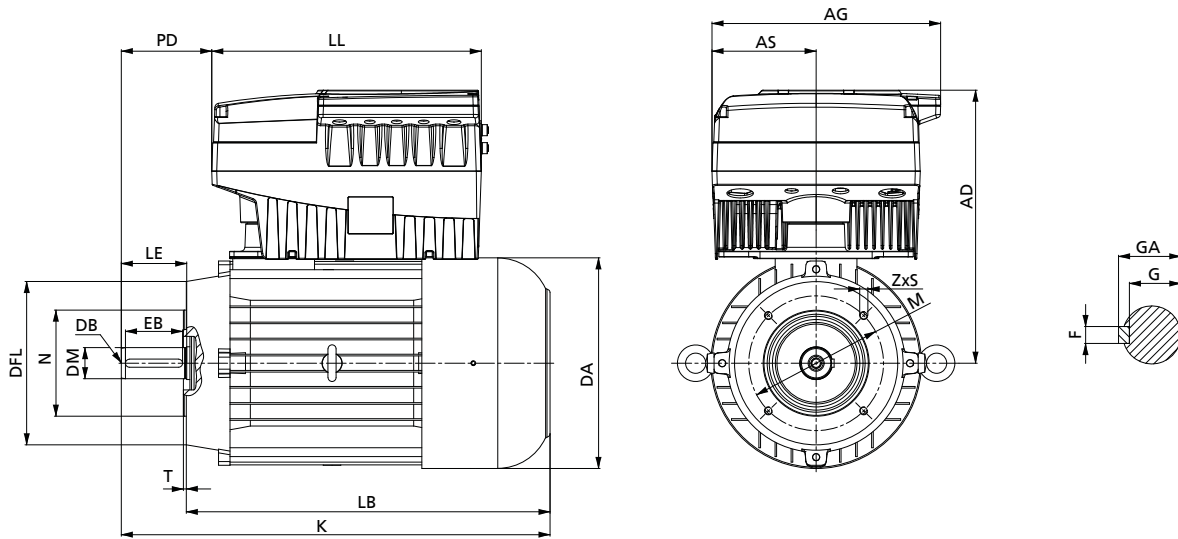

Fig. 6: Version with FT flange with tapped holes (V18, etc.)

Motor with terminal box

Table 13: Position of terminal box

Installation type	Shaft centreline height 71 - 160 mm	Shaft centreline height 180 - 225 mm
B3	Not defined	360°
V15	Not defined	360°
All installation types, with motor-mounted PumpDrive 2	360°	360°

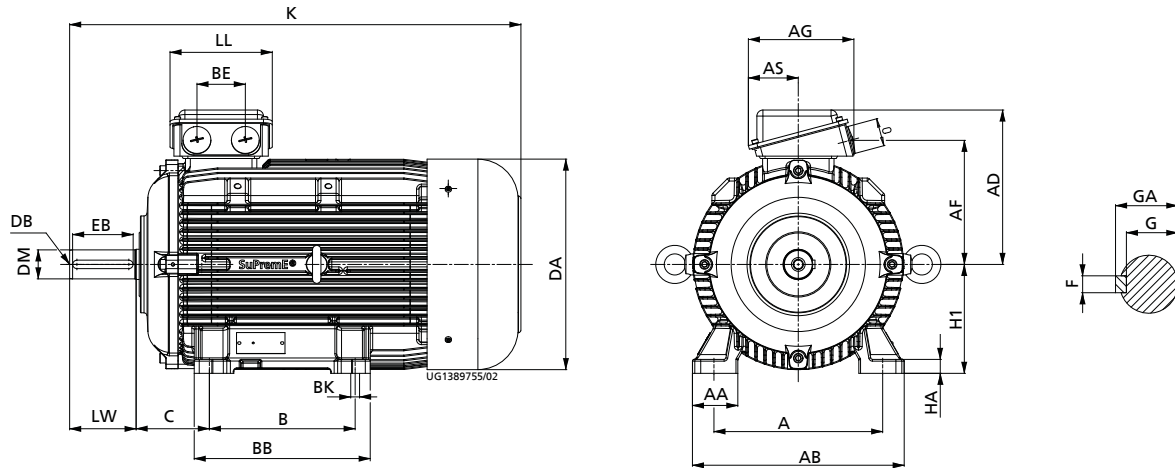

Fig. 7: Version with standard bearing cover (B3,...)

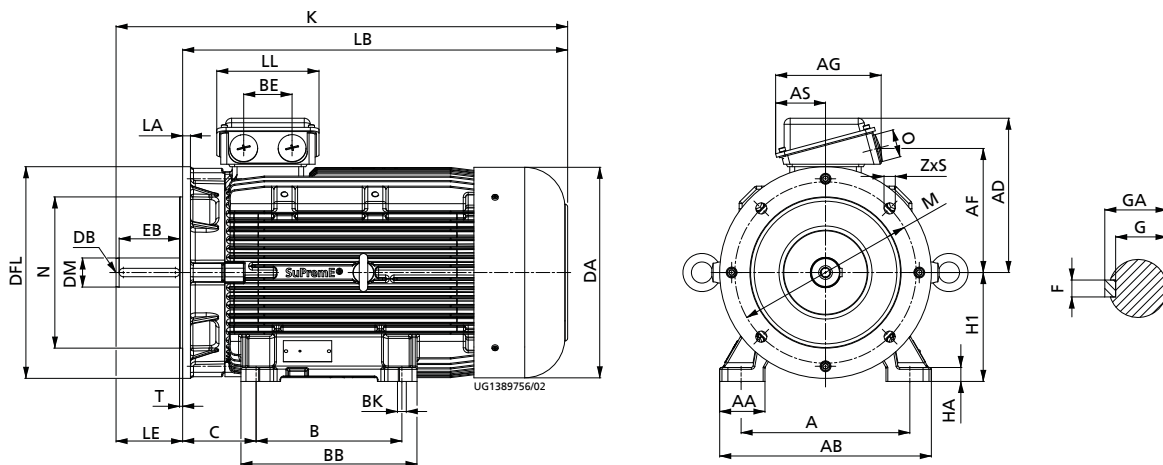

Fig. 8: Version with FF flange with clearance holes (V15,...)

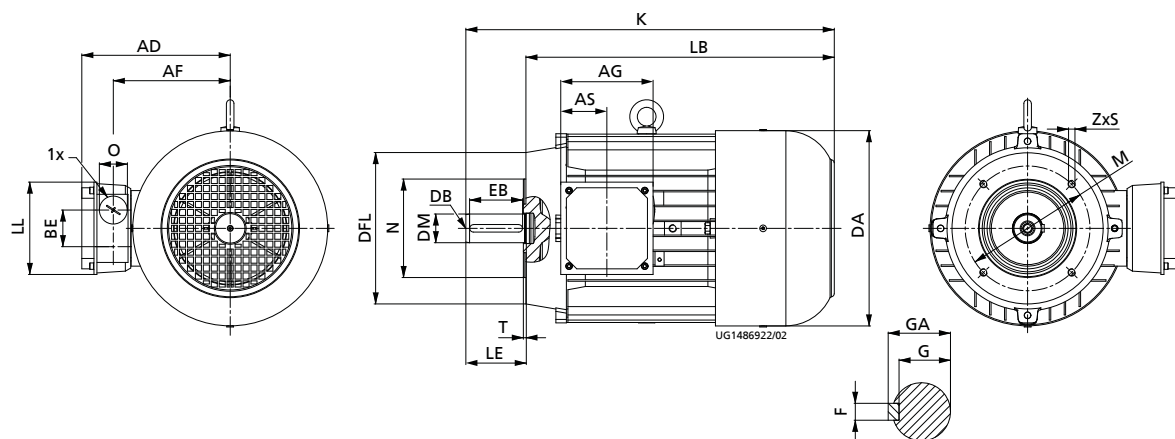

Fig. 9: Version with FT flange with tapped holes (V18,...)

4075.53/10-EN

Key
Table 14: Key: Code from dimension drawing = description

Code	Description	See drawing
A	Distance between centrelines of mounting holes	Front face
AA	Width of motor foot	Front face
AB	Distance from one outside edge to other outside edge of motor feet	Front face
AD	Distance between motor centreline and top edge of terminal box or PumpDrive	Front face
AF	Distance between motor centreline and cable gland opening	Front face
AG	Width of terminal box or PumpDrive	-
AS	Distance between motor centreline and outside edge on the side of terminal box or PumpDrive.	-
B	Distance between centrelines of mounting holes	Side view
BB	Distance from one outside edge to other outside edge of motor feet	Side view
BE	Distance between centrelines of the two cable gland openings	Side view
BK	Diameter of mounting holes in motor foot	Side view
C	Distance between shaft shoulder and centreline of mounting holes of adjacent motor feet	Side view
DA	Motor diameter	Front face
DB	Thread size of centre hole	Side view
DFL	Flange diameter	Side view
DM	Shaft diameter	Side view
EB	Length of drive-end key	Side view
F	Width of drive-end key	Detail
G	Distance between keyway base and opposite surface of the drive-end shaft end	Detail
GA	Distance between top of the key and opposite surface of the drive-end shaft end	Detail
H1	Shaft centreline height	Front face
HA	Motor foot thickness	Front face
K	Overall length of motor (incl. shaft end)	Side view
LA	Flange width	Side view
LB	Distance from flange mounting face to motor end (without shaft stub)	Side view
LE/LW	Length of shaft stub ¹⁴⁾	Side view
LL	Width of terminal box or PumpDrive	Side view
M	Diameter of mounting bolt circle at flange	Front face
N	Flange centring diameter	Side view
O	Diameter of cable gland opening	Side view or front face
PD	Distance between shaft end or flange mounting face to outer edge of PumpDrive	-
S	Flange bolt hole diameter or nominal thread size	Front face
T	Flange centring depth	Side view
Z	Number of mounting holes	-

¹⁴⁾ LE = for installation types V1, V15 and V18, LW = installation type B3

Motor

Table 15: Motor dimensions

Motor	DA	DB	DM	H1	K	LE/LW ¹⁵⁾
	[mm]					
71M	138	M5	14	71	245	30
80M	158	M6	19	80	292	40
90S	176	M8	24	90	337	50
90L	176	M8	24	90	361	50
100L	194	M10	28	100	400	60
112M	219	M10	28	112	425	60
132S	259	M12	38	132	481	80
132M	259	M12	38	132	519	80
160M	308	M16	42	160	613	110
160L	308	M16	42	160	658	110
180M	356	M16	48	180	745	110
180L	356	M16	48	180	773	110
200L	396	M20	55	200	846	110
225S	449	M20	60	225	905	140
225M (2 poles)	449	M20	55	225	882	110
225M (4 poles)	449	M20	60	225	928	140

Motor feet

Table 16: Motor feet dimensions

Motor	A	AA _{max}	AB _{max}	B	BB _{max}	BK	C	HA _{max}
	[mm]							
71M	112	30	140	90	108	7	45	11
80M	125	36	160	100	125	10	50	13
90S	140	41	180	100	132	10	56	13
90L	140	41	180	125	155	10	56	12
100L	160	47	200	140	173	12	63	13
112M	190	51	228	140	177	12	70	14
132S	216	60	260	140	180	12	89	18
132M	216	60	260	178	218	12	89	18
160M	254	72	318	210	264	14,5	108	22
160L	254	72	318	254	308	14,5	108	22
180M	279	75	350	241	328	15	121	23
180L	279	75	350	279	328	15	121	23
200L	318	71	380	305	365	19	133	25
225S	356	92	436	286	361	19	149	34
225M	356	92	436	311	406	19	149	34

¹⁵⁾ LW = installation type B3

Terminal box

Table 17: Terminal box dimensions

Motor	AD	AF	AG	AS	BE	LL	O
	[mm]						
71M	127	80	114	57	40	114	M20
80M	131	99	114	57	47	114	M25
90S	137	106	114	57	47	114	M25
90L	137	106	114	57	47	114	M25
100L	149	114	114	57	47	114	M25
112M	169	133	120	60	50	142	M32
132S	191	154	122	61	50	142	M32
132M	191	154	122	61	50	142	M32
160M	239	189	186	93	83	186	M40
160L	239	189	186	93	83	186	M40
180M	296	239	265	112	85	197	M40
180L	296	239	265	112	85	197	M40
200L [30 kW]	314	257	265	112	90	224	M50
200L [37 kW]	314	257	265	112	90	224	M50
225S	339	282	266	124	90	224	M50
225M	339	282	266	124	90	224	M50

Motor-mounted PumpDrive 2

Table 18: Dimensions of motor-mounted PumpDrive 2

Motor	Size PumpDrive 2	AD	AG	AS	LL	PD	
		[mm]					
71M	A	237	190	85	260	35	4,5
80M	A	258	190	85	260	45	4,5
90S	A	265	190	85	260	58	8
90L [1,5 kW]	A	265	190	85	260	58	8
90L [2,2 kW]	B	255	211	93	290	63	11
100L	B	267	211	93	290	77	17
112M	B	315	211	93	290	89	29
132S	C	340	280	128	330	110	33
132M	C	340	280	128	330	110	33
160M [11 kW]	C	369	280	128	330	156	49
160M [15 kW]	D	458	350	160	460	169	62
160L	D	458	350	160	460	169	62
180M	D	463	350	160	460	175	80
180L	D	463	350	160	460	175	80
200L [30 kW]	D	480	350	160	460	205	89
200L [37 kW]	E	535	455	213	700	187	88
225S	E	556	455	213	700	233	88
225M	E	556	455	213	700	203	88

Key

Table 19: Key dimensions

Motor	EB	F	G	GA
	[mm]			
71M	22	5	11	16
80M	32	6	15,5	21,5
90S	40	8	20	27
90L	40	8	20	27
100L	50	8	24	31
112M	50	8	24	31
132S	70	10	33	41
132M	70	10	33	41
160M	90	12	37	45
160L	90	12	37	45
180M	100	14	42,5	51,5
180L	100	14	72,5	51,5
200L	100	16	49	59
225S (2 poles)	125	18	53	64
225M (2 poles)	100	16	49	59
225M (4 poles)	125	18	53	64

Motor flange

Table 20: Motor flange dimensions

Motor	Flange type															
	FT	FF	FF	FT	FF	FT	FF	FT	FF	FT	FF	FT	FF	FT	FF	
	DFL		LA _{max}	LB _{max}		M		N		S		T		Z		
	[mm]															
71M	105	160	10	214	214	85	130	70	110	M6	10	2,5	3,5	4	4	
80M	120	200	10	252	252	100	165	80	130	M6	12	3	3,5	4	4	
90S	140	200	10	287	287	115	165	95	130	M8	12	3	3,5	4	4	
90L	140	200	10	311	311	115	165	95	130	M8	12	3	3,5	4	4	
100L	160	250	15	340	340	130	215	110	180	M8	14,5	3,5	4	4	4	
112M	160	250	15	365	365	130	215	110	180	M8	14,5	3,5	4	4	4	
132S	200	300	16	401	401	165	265	130	230	M10	14,5	3,5	4	4	4	
132M	200	300	16	439	439	165	265	130	230	M10	14,5	3,5	4	4	4	
160M	250	350	24	503	503	215	300	180	250	M12	18,5	4	5	4	4	
160L	250	350	24	548	548	215	300	180	250	M12	18,5	4	5	4	4	
180M	-	350	13	635	635	-	300	-	250	-	18,5	-	5	4	4	
180L	-	350	13	663	663	-	300	-	250	-	18,5	-	5	4	4	
200L	-	400	15	736	736	-	350	-	300	-	18,5	-	5	4	4	
225S	-	450	16	747	747	-	400	-	350	-	18,5	-	5	8	8	
225M	-	450	16	788	788	-	400	-	350	-	18,5	-	5	8	8	

Mounting arrangements

Table 21: Mounting arrangements

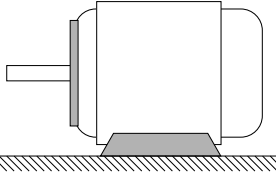
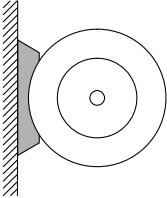
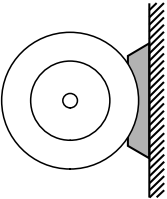
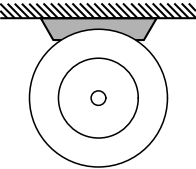
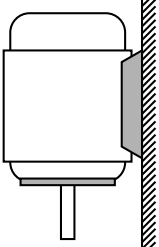
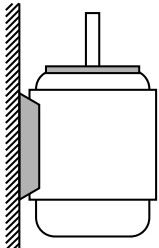
Standard mounting arrangement	Further mounting arrangements	Shaft centreline height		
		H ≤ 132	H ≤ 160	H ≥ 180
[mm]				
 <p>IM B3</p>	 <p>IM B6</p>	-	✓	✓
	 <p>IM B7</p>	-	✓	✓
	 <p>IM B8</p>	-	✓	✓
	 <p>IM V5</p>	-	✓	✓
	 <p>IM V6</p>	-	✓	✓

4075.53/10-EN

Standard mounting arrangement	Further mounting arrangements	Shaft centreline height		
		H ≤ 132	H ≤ 160	H ≥ 180
		[mm]		
<p>IM V15</p>	<p>IM V35</p>	-	✓	✓
	<p>IM B35</p>	-	✓	✓
<p>IM V1</p>	<p>IM V3</p>	-	✓ ¹⁶⁾	-
	<p>IM B5</p>	-	✓ ¹⁶⁾	-
<p>IM V18</p>	<p>IM B14</p>	✓	-	-
	<p>IM V19</p>	✓	-	-

4075.53/10-EN

¹⁶⁾ Feet can be removed from IM V15 basic type of construction

Available torque

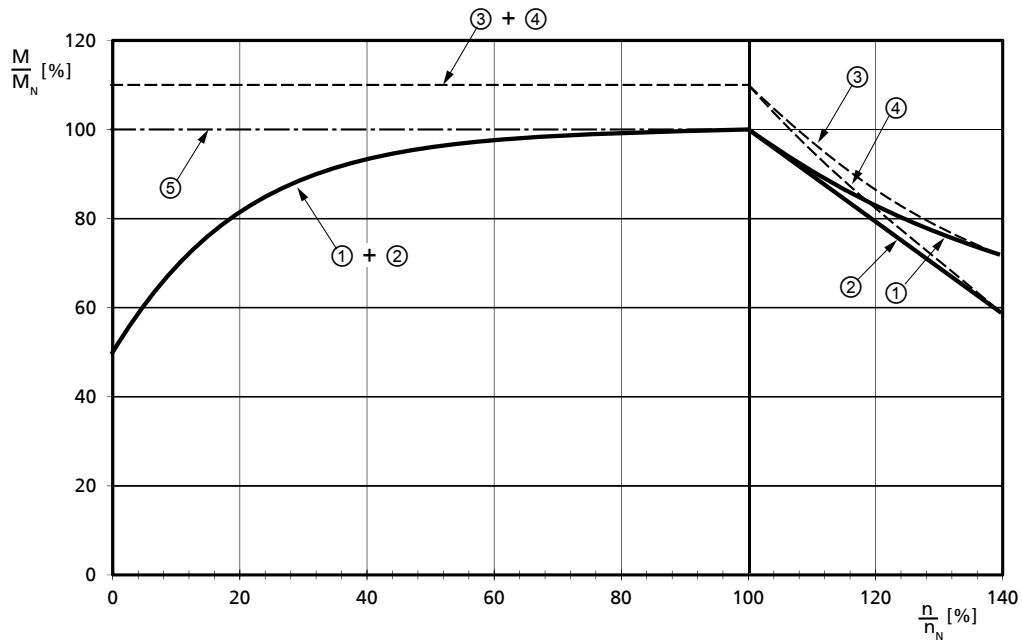

Fig. 10: Available torque

①	IC 411	S1 continuous duty
②	IC 411, from size 180	S1 continuous duty
③	IC 411 / IC 416	S2 duty (max. 10 seconds)
④	IC 411 / IC 416, from size 180	S2 duty (max. 10 seconds)
⑤	IC 416	S1 continuous duty

IC411 For surface cooling with fan mounted on drive shaft/TEFC (DIN EN 60034-6)

IC416 For external cooling by separate fan/TEFV (DIN EN 60034-6)

General arrangement drawings with list of components

Variant made of aluminium

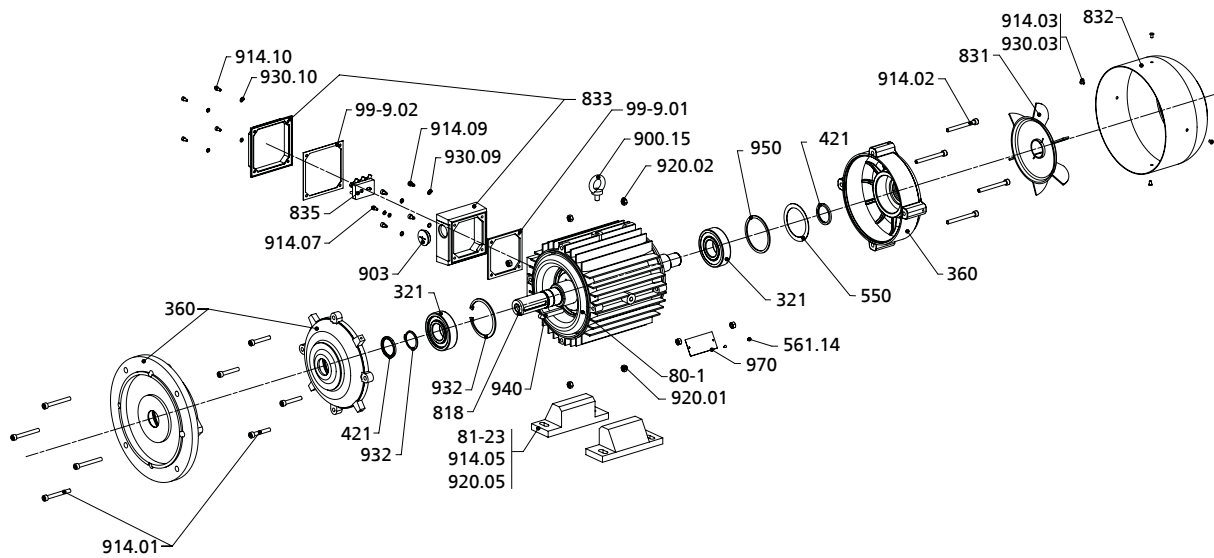

UG1492721

Fig. 11: Variant made of aluminium

Table 22: List of components

Part No.	Description	Part No.	Description
80-1	Motor unit (motor housing with stator)	833	Terminal box
81-23	Motor foot	835	Terminal board
99-9.01/02	Set of sealing elements	900.15	Bolt/screw
321	Radial ball bearing	903	Screw plug
360	Bearing cover	914.01/02/03/05/07/09/10	Hexagon socket head cap screw
421	Lip seal	920.01/02/05	Nut
550	Disc	930.03/09/10	Safety device
561.14	Grooved pin	932	Circlip
818	Rotor	940	Key
831	Fan impeller	950	Spring
832	Fan hood	970	Name plate

Variant made of grey cast iron

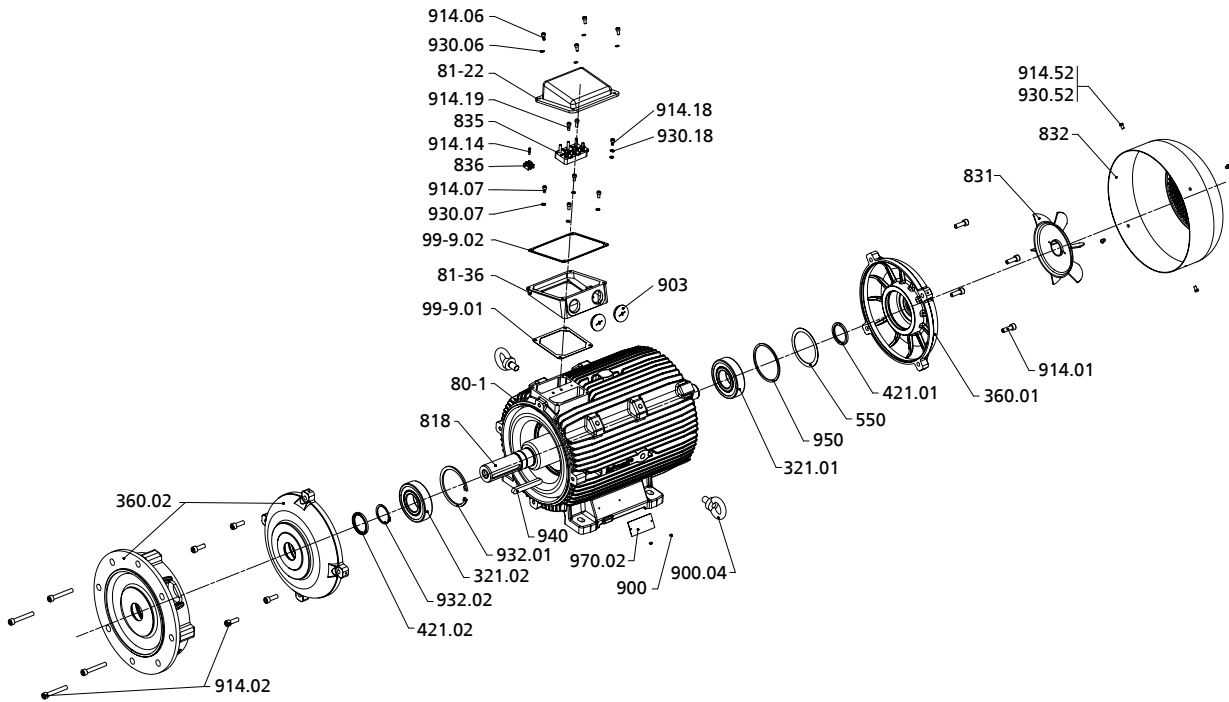

UG1492278

Fig. 12: Variant made of grey cast iron

Table 23: List of components

Part No.	Description	Part No.	Description
80-1	Motor unit (motor housing with stator)	835	Terminal board
81-22	Terminal box cover	836	Terminal strip
81-36	Terminal box base	900.04	Bolt/screw
99-9.01/02	Set of sealing elements	903	Screw plug
321.01/02	Radial ball bearing	914.01/02/06/07/14/18/19/52	Hexagon socket head cap screw
360.01/02	Bearing cover	930.06/07/18/52	Safety device
421.01/02	Lip seal	932.01/02	Circlip
550	Disc	940	Key
818	Rotor	950	Spring
831	Fan impeller	970.02	Name plate
832	Fan hood		

Adapter, sizes A and B

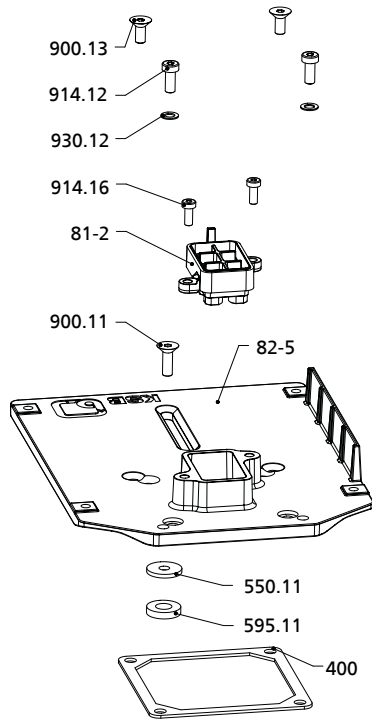

UG1492488

Fig. 13: Adapter, sizes A and B

Table 24: List of components

Part No.	Description	Part No.	Description
81-2	Plug	595.11	Anti-vibration pad
82-5	Adapter	900.11/.13	Bolt/screw
400	Gasket	914.12/.16	Hexagon socket head cap screw
550.11	Disc	930.12	Safety device

Adapter, size C

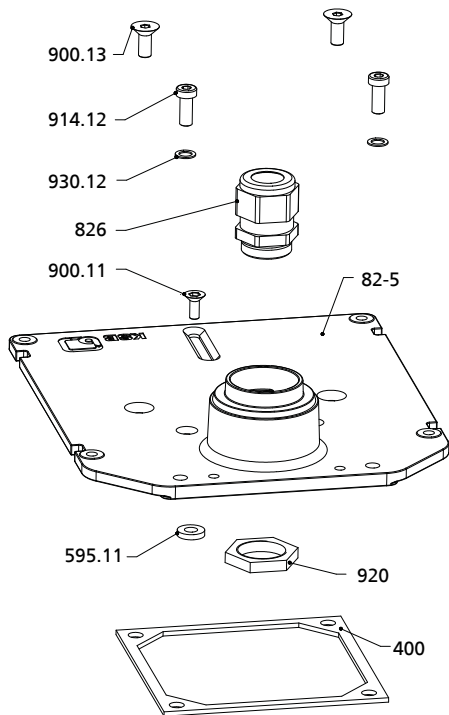

UG1492488

Fig. 14: Adapter, size C

Table 25: List of components

Part No.	Description	Part No.	Description
82-5	Adapter	900.11/.13	Bolt/screw
400	Gasket	914.12	Hexagon socket head cap screw
595.11	Anti-vibration pad	920	Nut
826	Cable gland	930.12	Safety device

Adapter, sizes D and E

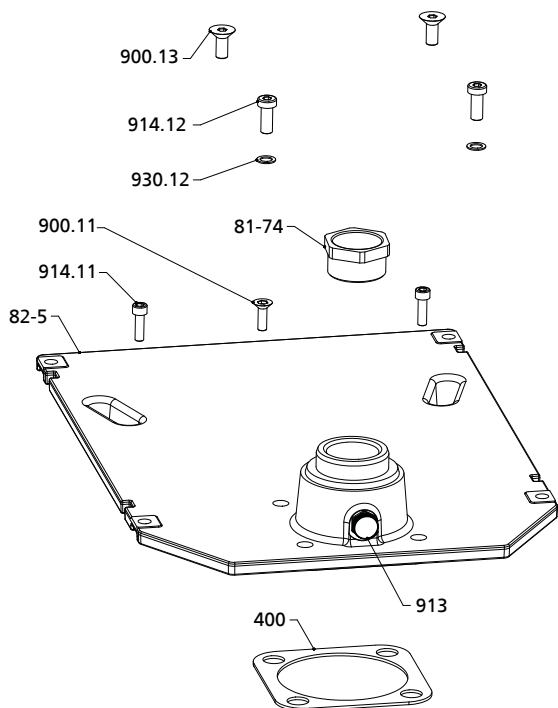

Fig. 15: Adapter, sizes D and E

Table 26: List of components

Part No.	Description	Part No.	Description
81-74 ¹⁷⁾	Pressure screw	913	Pressure balancing element
82-5	Adapter	914.11/.12	Hexagon socket head cap screw
400 ¹⁸⁾	Gasket	930.12	Safety device
900.11/.13 ¹⁷⁾	Bolt/screw		

¹⁷⁾ Not when using an adapter with pressure balancing element

¹⁸⁾ Only when using an adapter with pressure balancing element

Glossary

IE4

Efficiency class to IEC TS 60034-30-2:2016 = Super Premium Efficiency (IE = International Efficiency)

IE5

Efficiency class to IEC TS 60034-30-2:2016 = Ultra Premium Efficiency (IE = International Efficiency)

Mat. No.

This identification number is composed of an 8-digit numerical code that uniquely identifies a product entered in SAP.



KSB SE & Co. KGaA
Johann-Klein-Straße 9 • 67227 Frankenthal (Germany)
Tel. +49 6233 86-0
www.ksb.com